

- 24-hour Telephone Number: (937) 847-3200
 - Use for urgent or emergency needs for technical support, service and/or replacement parts
 - Routine Technical Inquiries: techsupport@motoman.com
- Allow up to 36 hours for response

YRC1000 OPTIONS INSTRUCTIONS

FOR FUNCTIONAL SAFETY FUNCTION

Upon receipt of the product and prior to initial operation, read these instructions thoroughly, and retain for future reference.

MOTOMAN INSTRUCTIONS

MOTOMAN-□□□ INSTRUCTIONS
YRC1000 INSTRUCTIONS
YRC1000 OPERATOR'S MANUAL (GENERAL) (SUBJECT SPECIFIC)
YRC1000 MAINTENANCE MANUAL
YRC1000 ALARM CODES (MAJOR ALARMS) (MINOR ALARMS)

Have the following information available when contacting the YASKAWA Representative:

- System
- Primary Application
- Software Version (*Located on Programming Pendant by selecting: {Main Menu} - {System Info} - {Version}*)
- Warranty ID (*Located on Robot Controller*)
- Robot Serial Number (*Located on Manipulator data plate*)
- Robot Sales Order Number (*Located on Robot controller data plate*)



DANGER

- This manual explains the functional safety function of the YRC1000 system. Read this manual carefully and be sure to understand its contents before handling the YRC1000. Any matter, including operation, usage, measures, and an item to use, not described in this manual must be regarded as “prohibited” or “improper”.
- General information related to safety are described in “Chapter 1. Safety” of the YRC1000 INSTRUCTIONS. To ensure correct and safe operation, carefully read “Chapter 1. Safety” of the YRC1000 INSTRUCTIONS.



CAUTION

- In some drawings in this manual, protective covers or shields are removed to show details. Make sure that all the covers or shields are installed in place before operating this product.
- YASKAWA is not responsible for incidents arising from unauthorized modification of its products. Unauthorized modification voids the product warranty.

NOTICE

- The drawings and photos in this manual are representative examples and differences may exist between them and the delivered product.
- YASKAWA may modify this model without notice when necessary due to product improvements, modifications, or changes in specifications. If such modification is made, the manual number will also be revised.
- If your copy of the manual is damaged or lost, contact a YASKAWA representative to order a new copy. Be sure to tell the representative the manual number listed on the front cover.

Notes for Safe Operation

Read this manual carefully before installation, operation, maintenance, or inspection of your product.

In this manual, the Notes for Safe Operation are classified as “DANGER”, “WARNING”, “CAUTION”, or “NOTICE”.



DANGER

Indicates an imminently hazardous situation which, if not avoided, will result in death or serious injury. Safety Signs identified by the signal word DANGER should be used sparingly and only for those situations presenting the most serious hazards.



WARNING

Indicates a potentially hazardous situation which, if not avoided, will result in death or serious injury. Hazards identified by the signal word WARNING present a lesser degree of risk of injury or death than those identified by the signal word DANGER.



CAUTION

Indicates a hazardous situation, which if not avoided, could result in minor or moderate injury. It may also be used without the safety alert symbol as an alternative to “NOTICE”.

NOTICE

NOTICE is the preferred signal word to address practices not related to personal injury. The safety alert symbol should not be used with this signal word. As an alternative to “NOTICE”, the word “CAUTION” without the safety alert symbol may be used to indicate a message not related to personal injury.

Even items described as “CAUTION” may result in a serious accident in some situations.

At any rate, be sure to follow these important items.



To ensure safe and efficient operation at all times, be sure to follow all instructions, even if not designated as “DANGER”, “WARNING” and “CAUTION”.



DANGER

- Before operating the manipulator, make sure the servo power is turned OFF by performing the following operations. When the servo power is turned OFF, the SERVO ON LED on the programming pendant is turned OFF.
 - Press the emergency stop buttons on the front door of the YRC1000, on the programming pendant, on the external control device, etc.
 - Disconnect the safety plug of the safety fence. (when in the play mode or in the remote mode)

If operation of the manipulator cannot be stopped in an emergency, personal injury and/or equipment damage may result.

Fig. : Emergency Stop Button



- Before releasing the emergency stop, make sure to remove the obstacle or error caused the emergency stop, if any, and then turn the servo power ON.

Failure to observe this instruction may cause unintended movement of the manipulator, which may result in personal injury.

Fig. : Release of Emergency Stop



- Observe the following precautions when performing a teaching operation within the manipulator's operating range:
 - Be sure to perform lockout by putting a lockout device on the safety fence when going into the area enclosed by the safety fence. In addition, the operator of the teaching operation must display the sign that the operation is being performed so that no other person closes the safety fence.
 - View the manipulator from the front whenever possible.
 - Always follow the predetermined operating procedure.
 - Always keep in mind emergency response measures against the manipulator's unexpected movement toward a person.
 - Ensure a safe place to retreat in case of emergency.

Failure to observe this instruction may cause improper or unintended movement of the manipulator, which may result in personal injury.

- Confirm that no person is present in the manipulator's operating range and that the operator is in a safe location before:
 - Turning ON the YRC1000 power
 - Moving the manipulator by using the programming pendant
 - Running the system in the check mode
 - Performing automatic operations

Personal injury may result if a person enters the manipulator's operating range during operation. Immediately press an emergency stop button whenever there is a problem. The emergency stop buttons are located on the front panel of the YRC1000 and on the upper right of the programming pendant.

- Read and understand the Explanation of the Warning Labels before operating the manipulator.



WARNING

- Perform the following inspection procedures prior to conducting manipulator teaching. If there is any problem, immediately take necessary steps to solve it, such as maintenance and repair.
 - Check for a problem in manipulator movement.
 - Check for damage to insulation and sheathing of external wires.
- Always return the programming pendant to the hook on the YRC1000 cabinet after use.

If the programming pendant is left unattended on the manipulator, on a fixture, or on the floor, the Enable Switch may be activated due to surface irregularities of where it is left, and the servo power may be turned ON. In addition, in case the operation of the manipulator starts, the manipulator or the tool may hit the programming pendant left unattended, which may result in personal injury and/or equipment damage.

Definition of Terms Used Often in This Manual

The MOTOMAN is the YASKAWA industrial robot product.

The MOTOMAN usually consists of the manipulator, the controller, the programming pendant, and supply cables.

In this manual, the equipment is designated as follows.

| Equipment | Manual Designation |
|--|---------------------|
| YRC1000 controller | YRC1000 |
| YRC1000 programming pendant | Programming pendant |
| Cable between the manipulator and the controller | Manipulator cable |

Descriptions of the programming pendant keys, buttons, and displays are shown as follows:

| Equipment | Manual Designation | |
|---------------------|-----------------------------|---|
| Programming Pendant | Character Keys /Symbol Keys | The keys which have characters or symbols printed on them are denoted with []. e.g. [ENTER] |
| | Axis Keys /Numeric Keys | [Axis Key] and [Numeric Key] are generic names for the keys for axis operation and number input. |
| | Keys pressed simultaneously | When two keys are to be pressed simultaneously, the keys are shown with a "+" sign between them, e.g. [SHIFT]+[COORD]. |
| | Mode Switch | Mode Switch can select three kinds of modes that are denoted as follows: REMOTE, PLAY or TEACH. (The switch names are denoted as symbols) |
| | Button | The three buttons on the upper side of the programming pendant are denoted as follows: START, HOLD, or EMERGENCY STOP. (The button names are denoted as symbols) |
| | Displays | The menu displayed in the programming pendant is denoted with { }. e.g. {JOB} |



Description of the Operation Procedure

In the explanation of the operation procedure, the expression “Select . . .” means that the cursor is moved to the object item and [SELECT] is pressed, or that the item is directly selected by touching the screen.

Registered Trademark

In this manual, names of companies, corporations, or products are trademarks, registered trademarks, or brand names for each company or corporation. The indications of (R) and TM are omitted.

 Contents

| | | |
|---------|---|------|
| 1 | Overview of the Function | 1-1 |
| 1.1 | Outline | 1-1 |
| 1.2 | List of Safety Functions..... | 1-1 |
| 1.3 | Structure of Configuration Files | 1-2 |
| 2 | System Configuration..... | 2-1 |
| 2.1 | Outline | 2-1 |
| 2.1.1 | Safety Circuit Board (JANCD-ASF01-E)..... | 2-1 |
| 2.1.2 | Expansion Safety I/O Board (JANCD-ASF02-E) | 2-1 |
| 2.1.3 | Expansion Safety Terminal Block Board | 2-2 |
| 2.1.4 | Wiring Procedure of the Terminal Block | 2-5 |
| 2.1.5 | Functional Safety General-Purpose Input Signal 1 to 8..... | 2-7 |
| 2.1.6 | Functional Safety General-Purpose Output Signal 1 to 8..... | 2-8 |
| 2.2 | Board Arrangement..... | 2-11 |
| 2.3 | System Configuration for Dual-Arm Manipulator | 2-12 |
| 3 | Common Operation..... | 3-1 |
| 3.1 | Security Mode When Using This Function..... | 3-1 |
| 3.2 | Readback Operation | 3-3 |
| 3.2.1 | Readback Operation of the Configuration File..... | 3-3 |
| 3.2.2 | Operations in Which the READBACK Window Is Shown | 3-5 |
| 3.2.2.1 | Readback Operation of the Function Disable Mode..... | 3-6 |
| 3.2.2.2 | Readback Operation of the Range Combination..... | 3-8 |
| 3.2.2.3 | Readback Operation of the Robot Interference Model..... | 3-8 |
| 3.3 | External Memory Device (Saving/Loading)..... | 3-9 |
| 4 | Details of Functional Safety Function..... | 4-1 |
| 4.1 | Axis Range Limit Function | 4-1 |
| 4.1.1 | Outline | 4-1 |
| 4.1.2 | Axis Range Limit Function Window | 4-3 |
| 4.1.3 | Axis Range Limit Condition File Setting..... | 4-5 |
| 4.1.4 | Confirming Method of Each Axis Operating Angle | 4-8 |
| 4.1.5 | Confirmation of Safety Range..... | 4-12 |
| 4.1.6 | Start the Axis Range Limit Operation | 4-13 |
| 4.1.7 | Monitoring Status Confirmation Display..... | 4-14 |
| 4.2 | Axis Speed Monitor Function | 4-17 |
| 4.2.1 | Outline | 4-17 |

 Contents

| | | |
|--------|--|------|
| 4.2.2 | Axis Speed Monitor Function Window | 4-18 |
| 4.2.3 | Axis Speed Monitor Condition File Setting | 4-20 |
| 4.2.4 | Start the Axis Speed Monitor Operation | 4-22 |
| 4.3 | Robot Range Limit Function | 4-23 |
| 4.3.1 | Outline | 4-23 |
| 4.3.2 | Robot Range Limit Function Window | 4-26 |
| 4.3.3 | Robot Range Limit Function Condition File Setting Window | 4-29 |
| 4.3.4 | Confirmation of the Safety Range | 4-39 |
| 4.3.5 | Starting the Robot Range Limit | 4-41 |
| 4.3.6 | Switch the Monitoring Area | 4-42 |
| 4.3.7 | Safety Range and Manipulator Position | 4-44 |
| 4.3.8 | Proximity Warning Buzzer Setting | 4-48 |
| 4.3.9 | Combining Function of Multiple Monitoring Areas | 4-50 |
| 4.3.10 | Extend Function of Robot Interference Model | 4-53 |
| 4.4 | Speed Limit Function | 4-55 |
| 4.4.1 | Outline | 4-55 |
| 4.4.2 | Speed Limit Function Window | 4-57 |
| 4.4.3 | Speed Limit Function Condition File Setting Window | 4-59 |
| 4.4.4 | Starting the Speed Limit | 4-62 |
| 4.4.5 | Speed Limit in Teach Mode | 4-62 |
| 4.5 | Tool Angle Monitor Function | 4-64 |
| 4.5.1 | Outline | 4-64 |
| 4.5.2 | Tool Angle Monitor Function Window | 4-65 |
| 4.5.3 | Tool Angle Monitor Condition File Setting | 4-67 |
| 4.5.4 | Confirmation of Tool Angle Limit Monitor | 4-70 |
| 4.5.5 | Starting the Tool Angle Monitor | 4-71 |
| 4.6 | Tool Change Monitor Function | 4-72 |
| 4.6.1 | Outline | 4-72 |
| 4.6.2 | Tool Change Monitor Function Window | 4-73 |
| 4.6.3 | Tool Change Monitor Condition File Setting | 4-75 |
| 4.6.4 | Confirmation of Tool Change Monitor | 4-76 |
| 4.6.5 | Starting the Tool Change Monitor | 4-76 |
| 4.6.6 | When Using the Tool Change Monitor Function | 4-77 |
| 4.7 | Tool Number Selection Function | 4-82 |
| 4.7.1 | Outline | 4-82 |

 Contents

| | | |
|-------|---|------|
| 4.7.2 | Tool Number Selection Function Window..... | 4-84 |
| 4.7.3 | Tool Number Selection Condition File Setting..... | 4-86 |
| 4.7.4 | Confirmation of Tool Number Selection..... | 4-87 |
| 4.7.5 | Starting the Tool Number Selection..... | 4-87 |
| 4.7.6 | When Using the Tool Number Selection Function..... | 4-88 |
| 4.8 | Common Setting Item for the Condition File..... | 4-93 |
| 5 | Safety Signal..... | 5-1 |
| 5.1 | Allocation of Safety Logic Circuit Extended Signal..... | 5-2 |
| 5.2 | Allocation of Safety Fieldbus Signal..... | 5-4 |
| 5.3 | Settings of Safety Function Condition File..... | 5-6 |
| 5.4 | File Switching to Valid/Invalid by the Safety Input Signal..... | 5-8 |
| 5.5 | Safety Signal Output Value..... | 5-11 |
| 6 | Common Settings..... | 6-1 |
| 6.1 | Function Disable Mode Setting..... | 6-1 |
| 6.1.1 | Restrictions While Function Disable Mode Is Enabled..... | 6-3 |
| 6.1.2 | Security Level Setting for Function Disable Mode..... | 6-4 |
| 6.2 | External Axis Coasting Value Setting..... | 6-5 |
| 6.3 | Tool File Setting..... | 6-8 |
| 6.4 | Tool Interference File Setting..... | 6-9 |
| 6.5 | Security Level Setting for Tool File and Tool Interference Files..... | 6-13 |
| 6.6 | Using the PMT Function Together with the Functional Safety Function..... | 6-15 |
| 6.6.1 | How to Use the PMT Function Together with the Functional Safety Function..... | 6-15 |
| 6.6.2 | Monitoring the Amount of Change in the Tool Files..... | 6-19 |
| 6.6.3 | Tool File Verification Check in a System Using the PMT Function Together with the Functional Safety Function..... | 6-22 |
| 6.7 | Disabling Functional Safety by Changing Connection Settings..... | 6-23 |
| 7 | Data Protection..... | 7-1 |
| 7.1 | Saving Dual Data..... | 7-1 |
| 7.2 | FLASH Data Reset..... | 7-2 |
| 7.3 | Change of Condition File by an External Device..... | 7-4 |
| 7.3.1 | Outputting the CRC Value to the External Memory Device..... | 7-4 |
| 7.3.2 | Confirming Method of the CRC Value..... | 7-5 |
| 7.3.3 | Register Output of the CRC Value..... | 7-9 |

Contents

| | | |
|-------|--|------|
| 7.3.4 | Data Monitor on the Total CRC Confirmation Window | 7-11 |
| 7.3.5 | Save Data CRC Check Function (FSU) | 7-15 |
| 8 | Specific Output Signal..... | 8-1 |
| 9 | Restriction..... | 9-1 |
| 9.1 | Functions Cannot Be Used Concurrently with Functional Safety Function | 9-1 |
| 9.1.1 | Functions Which Modifies Parameter or File during Playback Operation | 9-1 |
| 9.2 | Functions Conditionally Used Concurrently with Functional Safety Function..... | 9-2 |
| 9.2.1 | Conveyor Synchronized Function, COMARC Function..... | 9-2 |
| 9.2.2 | Servo Float Function | 9-2 |
| 9.2.3 | Motor Gun Function..... | 9-2 |
| 9.2.4 | MotoPlus Function and MotoFit Function | 9-2 |
| 9.2.5 | T-axis Endless Function, External Axis Endless Function..... | 9-2 |
| 9.2.6 | Gun Change Function and Group Change Function..... | 9-3 |
| 9.2.7 | Multi Layer Function | 9-3 |
| 9.3 | Restriction of Operation..... | 9-4 |
| 9.3.1 | File/Parameter Loading | 9-4 |
| 10 | Error..... | 10-1 |

| | |
|-----|--------------------------|
| 1 | Overview of the Function |
| 1.1 | Outline |

1 Overview of the Function

1.1 Outline

By using the functional safety function, each of the two CPUs mounted on the safety circuit board independently acquires the encoder feedback pulse of the manipulator, and, based on this pulse, the position and speed of the manipulator and the posture of its tool are monitored.

The data such as the result of safety monitoring is compared by each of the two CPUs, and the power supply to the motor is suspended and the manipulator is completely stopped when an error is detected.

With this function, improving of the safety of the manipulator's motion and minimizing of the equipment layouts when manipulators are installed are realized.

1.2 List of Safety Functions

To the functional safety function, following six different functions for monitoring purposes are equipped.

- (1) Axis range limit function
Monitors each axis angle to be equal to or in the designated safety area.
- (2) Axis speed monitor function
Monitors each axis speed to be equal or slower than the designated speed.
- (3) Robot range limit function
Monitors the manipulator arm or its tool to be in the designated safety area.
- (4) Speed limit function
Monitors the speed of manipulator TCP (Tool Center Point) and its FCP (Flange Center Point) when the robot control group is monitored.
If the station control group is monitored, it monitors the axis speed.
- (5) Tool angle monitor function
Monitors the manipulator tool angle to be inside the range of limited angle when the angle is centered on the designated standard posture.
- (6) Tool change monitor function
Monitors the tool file used in the functional safety function to be consistent with the user specified tool file. Cannot be used concurrently with the tool number select function.
- (7) Tool number select function
Selects the tool number used in the functional safety function.
Cannot be used concurrently with the tool change monitor function.

These safety functions conform to the following safety standards.

- EN ISO 13849-1: 2015 Cat.3 / PL d
- EN 62061(IEC 61508) SIL CL2

- 1 Overview of the Function
- 1.3 Structure of Configuration Files

1.3 Structure of Configuration Files

Most of the configuration files for the functional safety are listed in the {SAFETY FUNC.} menu under the main menu of the programming pendant.

The files related to the functional safety shown below are expanded from the {SAFETY FUNC.} menu.

| Main menu | Sub menu (1st layer) | Sub menu (2nd layer) |
|--------------|--|---|
| SAFETY FUNC. | AXIS RANGE LIMIT status list window | AXIS RANGE LIMIT condition file (32 files/system) |
| | AXIS SPEED MONITOR status list window | AXIS SPEED MONITOR condition file (32 files/system) |
| | ROBOT RANGE LIMIT status list window | ROBOT RANGE LIMIT condition file (32 files/system) |
| | SPEED LIMIT status list window | SPEED LIMIT condition file (32 files/system) TEACH MODE SPEED LIMIT condition file (32 files/system) |
| | TOOL ANGLE MONITOR status list window | TOOL ANGLE MONITOR condition file (32 files/system) |
| | TOOL CHANGE MONITOR status list window | TOOL CHANGE MONITOR condition file (16 files/robot group) |
| | TOOL NUMBER SELECT status list window | TOOL NUMBER SELECT condition file (16 files/robot group) |

2 System Configuration

2.1 Outline

The functional safety function is performed by using the safety circuit board. For details on the safety circuit board, refer to “YRC1000 INSTRUCTIONS (RE-CTO-A221)”.

2.1.1 Safety Circuit Board (JANCD-ASF01-E)

For details on the safety circuit board, refer to “YRC1000 INSTRUCTIONS (RE-CTO-A221) 14.6.1 Safety Circuit Board (JANCD-ASF01-E)”.

2.1.2 Expansion Safety I/O Board (JANCD-ASF02-E)

The expansion safety I/O board (JANCD-ASF02-E) is an optional board used to add 8 input points and 8 output points as the safety I/O signals, and connected to the safety circuit board (JANCD-ASF01-E) by using a communication cable.

Fig. 2-1: Expansion Safety I/O Board (JANCD-ASF02-E)

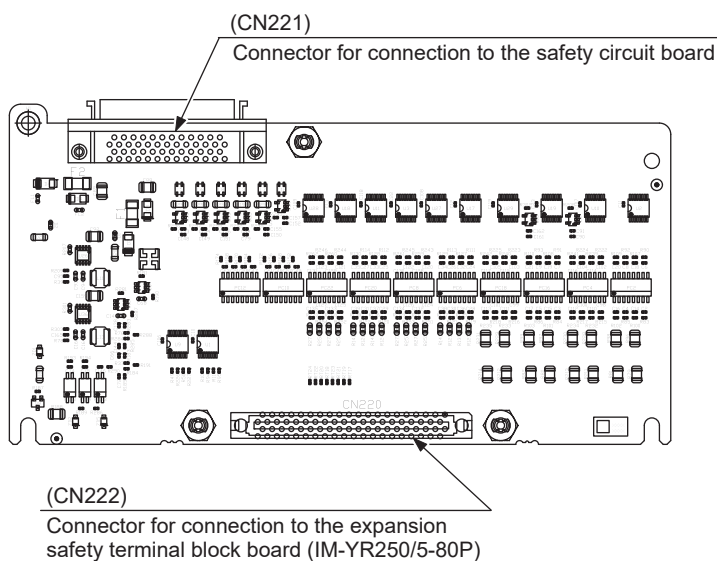

2.1.3 Expansion Safety Terminal Block Board

Safety signals are connected to the expansion safety terminal block board.

The type and main specifications of the expansion safety terminal block board are shown below.

| Item | Specification |
|---------------|---|
| Unit type | IM-YE250/5-80P |
| Function | Connects the functional safety general I/O signals. |
| Signal points | Input: 8 points/station Output: 8 points/station |

The following is the external view of the expansion safety terminal block board.

Fig. 2-2: Expansion Safety Terminal Block Board (IM-YE250/5-80P)

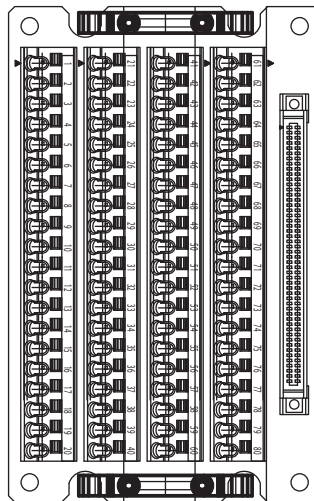

2 System Configuration
2.1 Outline

The following table shows details of the connection terminals.

Table 2-1: Connection Terminals of IM-YE250/5-80P (Sheet 1 of 2)

| Signal Name | Connection No. | Dual Signal | Function | Factory Setting |
|-------------|----------------|-------------|--|-----------------|
| XIN1_1+ | 1 | ○ | Functional Safety Universal Input 1 (Corresponding FSBIN01) | Open |
| XIN1_1- | 2 | | | |
| XIN1_2+ | 3 | ○ | Functional Safety Universal Input 2 (Corresponding FSBIN02) | Open |
| XIN1_2- | 4 | | | |
| XIN2_1+ | 5 | ○ | Functional Safety Universal Input 2 (Corresponding FSBIN02) | Open |
| XIN2_1- | 6 | | | |
| XIN2_2+ | 7 | ○ | Functional Safety Universal Output 1 (Corresponding FSBOU01) | Open |
| XIN2_2- | 8 | | | |
| XOUT1_1+ | 9 | ○ | Functional Safety Universal Output 1 (Corresponding FSBOU01) | Open |
| XOUT1_1- | 10 | | | |
| XOUT1_2+ | 11 | ○ | Functional Safety Universal Output 2 (Corresponding FSBOU02) | Open |
| XOUT1_2- | 12 | | | |
| XOUT2_1+ | 13 | ○ | Functional Safety Universal Output 2 (Corresponding FSBOU02) | Open |
| XOUT2_1- | 14 | | | |
| XOUT2_2+ | 15 | ○ | Functional Safety Universal Input 3 (Corresponding FSBIN03) | Open |
| XOUT2_2- | 16 | | | |
| XIN3_1+ | 21 | ○ | Functional Safety Universal Input 3 (Corresponding FSBIN03) | Open |
| XIN3_1- | 22 | | | |
| XIN3_2+ | 23 | ○ | Functional Safety Universal Input 4 (Corresponding FSBIN04) | Open |
| XIN3_2- | 24 | | | |
| XIN4_1+ | 25 | ○ | Functional Safety Universal Input 4 (Corresponding FSBIN04) | Open |
| XIN4_1- | 26 | | | |
| XIN4_2+ | 27 | ○ | Functional Safety Universal Output 3 (Corresponding FSBOU03) | Open |
| XIN4_2- | 28 | | | |
| XOUT3_1+ | 29 | ○ | Functional Safety Universal Output 3 (Corresponding FSBOU03) | Open |
| XOUT3_1- | 30 | | | |
| XOUT3_2+ | 31 | ○ | Functional Safety Universal Output 4 (Corresponding FSBOU04) | Open |
| XOUT3_2- | 32 | | | |
| XOUT4_1+ | 33 | ○ | Functional Safety Universal Output 4 (Corresponding FSBOU04) | Open |
| XOUT4_1- | 34 | | | |
| XOUT4_2+ | 35 | ○ | Functional Safety Universal Input 5 (Corresponding FSBIN05) | Open |
| XOUT4_2- | 36 | | | |
| XIN5_1+ | 41 | ○ | Functional Safety Universal Input 5 (Corresponding FSBIN05) | Open |
| XIN5_1- | 42 | | | |
| XIN5_2+ | 43 | ○ | Functional Safety Universal Input 6 (Corresponding FSBIN06) | Open |
| XIN5_2- | 44 | | | |
| XIN6_1+ | 45 | ○ | Functional Safety Universal Input 6 (Corresponding FSBIN06) | Open |
| XIN6_1- | 46 | | | |
| XIN6_2+ | 47 | ○ | Functional Safety Universal Input 6 (Corresponding FSBIN06) | Open |
| XIN6_2- | 48 | | | |

Table 2-1: Connection Terminals of IM-YE250/5-80P (Sheet 2 of 2)

| Signal Name | Connection No. | Dual Signal | Function | Factory Setting |
|----------------------|----------------|-------------|---|-----------------|
| XOUT5_1+ XOUT5_1- | 49 50 | ○ | Functional Safety Universal Output 5 (Corresponding FSBOUT05) | Open |
| XOUT5_2+ XOUT5_2- | 51 52 | | | |
| XOUT6_1+ XOUT6_1- | 53 54 | ○ | Functional Safety Universal Output 6 (Corresponding FSBOUT06) | Open |
| XOUT6_2+ XOUT6_2- | 55 56 | | | |
| XIN7_1+ XIN7_1- | 61 62 | ○ | Functional Safety Universal Input 7 (Corresponding FSBIN07) | Open |
| XIN7_2+ XIN7_2- | 63 64 | | | |
| XIN8_1+ XIN8_1- | 65 66 | ○ | Functional Safety Universal Input 8 (Corresponding FSBIN08) | Open |
| XIN8_2+ XIN8_2- | 67 68 | | | |
| XOUT7_1+ XOUT7_1- | 69 70 | ○ | Functional Safety Universal Output 7 (Corresponding FSBOUT07) | Open |
| XOUT7_2+ XOUT7_2- | 71 72 | | | |
| XOUT8_1+ XOUT8_1- | 73 74 | ○ | Functional Safety Universal Output 8 (Corresponding FSBOUT08) | Open |
| XOUT8_2+ XOUT8_2- | 75 76 | | | |

Refer to the connection diagram for the connection of each signal.

2.1.4 Wiring Procedure of the Terminal Block

For your safety, appropriate work must be done by following the instructions below.

NOTICE

- If the length of cable between the safety terminal block board and the connected device is longer than 30 m, make sure to use the shielded cable so that the electromagnetic resistant can be properly performed. Then the shield of shielded cable must come into contact with the controller's body.

■ Tool: Screwdriver

For the connection, be sure to use a screwdriver of an applicable size and configuration.

- WAGO standard screwdriver
WAGO 210-119
WAGO 210-119SB (Short, delivered with the product)



■ Applicable Wires

1. The length of the exposed conductor (L) must be as follows:

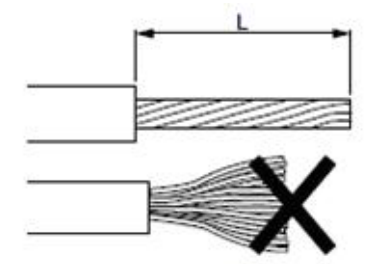

- The length of the exposed conductor for the terminal block (L)
WAGO series 250 (with 5.0 mm pitch): 9-10 mm
 - Applicable wire conductor: 0.5 mm² to 1.5 mm² (AWG20-16)
 - Applicable maximum wire outside diameter: 3.1 mm dia.
2. If the wire is bent or loose, make it straight as illustrated in the figure above.

■ **Wire Connection**

Terminal block: screwless clamp
terminal WAGO series 250

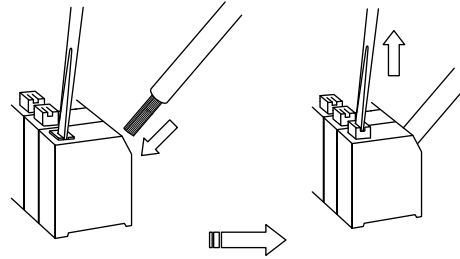
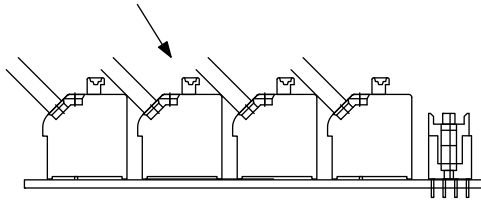

1. Place the screwdriver on the lever upright as shown in the figure above and push it straight down.
2. Insert the wire into the connection hole slowly until its leading end touches the end of the hole.
For thin wires, never insert the wire with force, or the wire jacket may get caught in.
3. Pull out the screwdriver to clamp the conductor with the spring.
4. Check if the wire is connected firmly by pulling the wire softly.

2.1.5 Functional Safety General-Purpose Input Signal 1 to 8

When opening this connection terminal, corresponding FSBIN turns ON(1).

When short circuiting this connection terminal, corresponding FSBIN turns OFF(0).



For safety reasons, dual circuits are used for the functional safety general-purpose input signals.

When state of the input mismatch continues for 500 ms or more, the following alarm occurs.

Alarm 4751: M-SAF GENERAL INPUT SIG. ERROR2

Fig. 2-3: Example of Connecting Functional Safety General-Purpose Input Signal

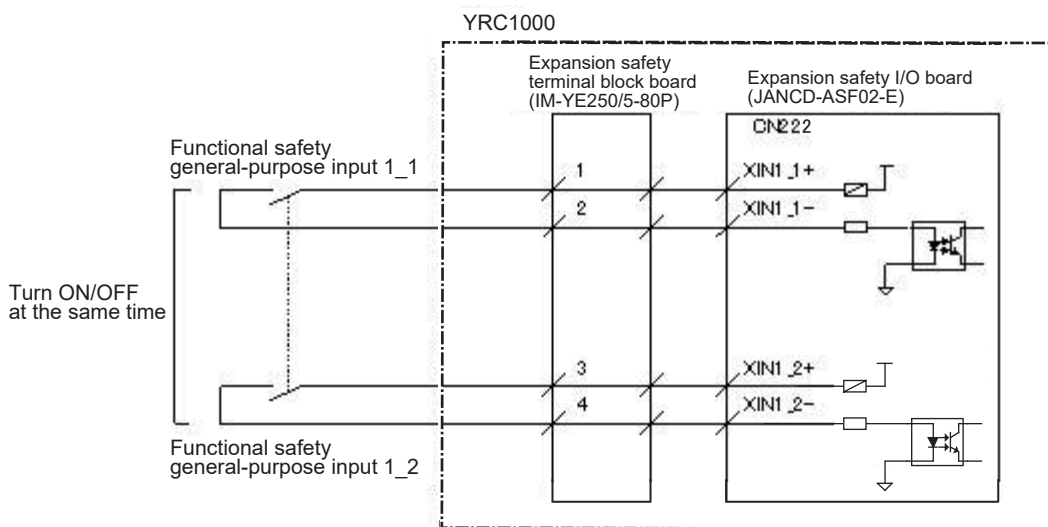

2.1.6 Functional Safety General-Purpose Output Signal 1 to 8

The output from the connection terminal differs depending on the status of FSBOUT.

When FSBOUT is ON(1), the output is 24 VDC.

When FSBOUT is OFF(0), the output is 0 V.

NOTE

- The rated output value is equal to or less than 24 VDC and 50 mA. Do not connect a load exceeding the rated output value.
- When connecting an inductive load, such as a safety relay, with the output circuit, suppress the surge voltage by using an inductive load with a built-in protective circuit or by connecting a flyback diode in parallel to the inductive load.
 Failure to observe this instruction may result in equipment damage.

NOTE

In case the other side of the duplicated functional safety general-purpose output signal is not output normally due to a board trouble, etc., the error is detected by the self-check circuit and following alarm occurs.

Alarm 4923: M-SAF GENERAL OUT SELF CHECK ERR2

NOTE

To conform with Safety Category 3 and PL-d at the whole manipulator system, monitoring of the safety devices (Safety PLC, etc.) in this system is required.

For this reason, to detect malfunction of the safety relay or disconnection of the signal line, etc., execute signal mismatch detection to the functional safety general-purpose output at the external safety device (Safety PLC, etc.) side.

Fig. 2-4: Example of Connecting Functional Safety General-Purpose Output Signal

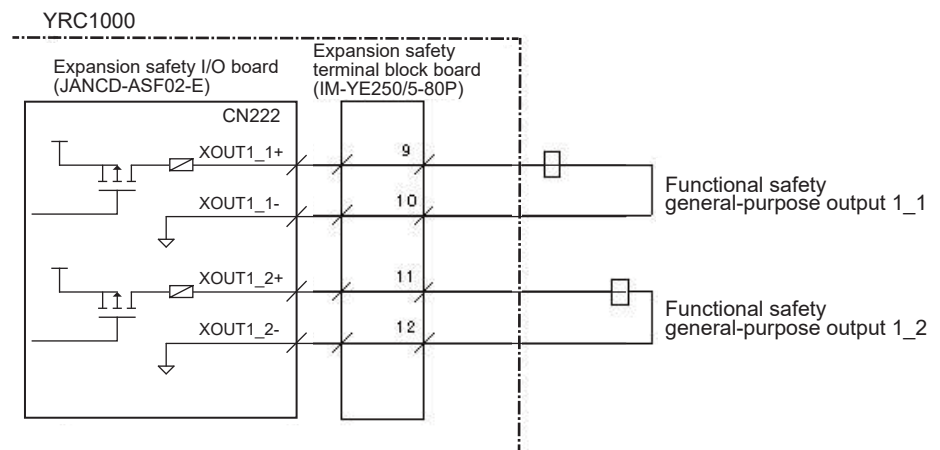

2 System Configuration

2.1 Outline

Fig. 2-5: Example Connection with an External Device (Safety PLC)
 (Connect the functional safety general-purpose output signal to the Safety PLC via the safety relay)

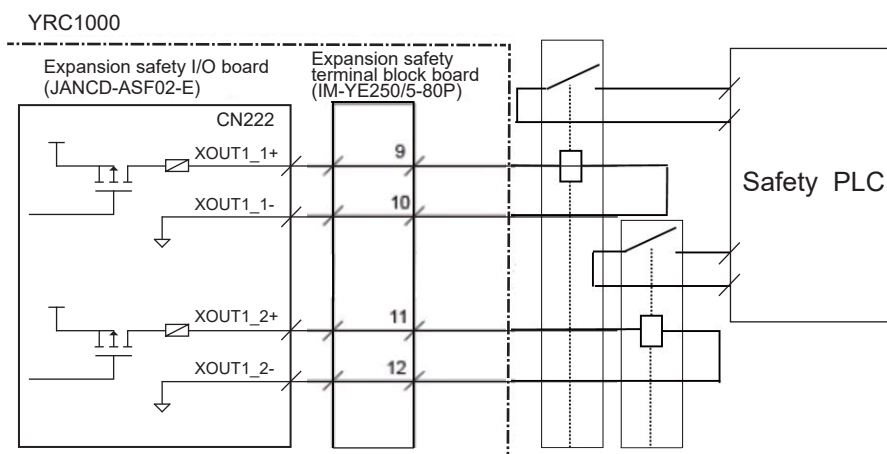

At the PLC side, monitor the contacting status of the duplicated safety relay, which is for connecting the safety general-purpose output signal with the Safety PLC, and connecting status of the signal line.

However, by using the general-purpose safety input signal which is equipped to the YRC1000, the duplicated safety relay can be monitored by the YRC1000.
 (As for the connecting status of the signal line, monitor it at the external device side.)

2 System Configuration
 2.1 Outline

Fig. 2-6: Example of Safety Relay Monitoring Circuit Board Using the General-Purpose Safety Input Signal (Example: GSIN signal is used)

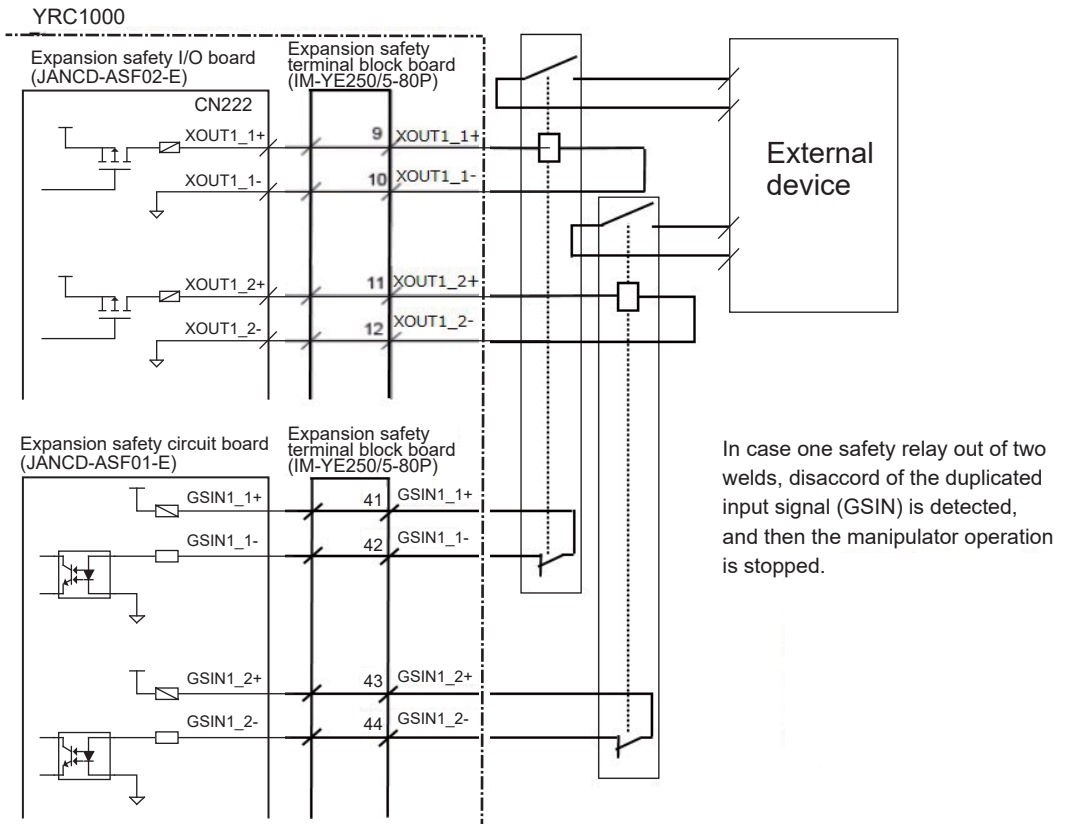

2.2 Board Arrangement

Following figures show the arrangement of each expansion safety I/O board and expansion safety terminal block board when they are mounted on the YRC1000.

■ Arrangement of the Expansion Safety I/O Board and Expansion Safety Terminal Block Board

Fig. 2-7: Arrangement of the Functional Safety Board (YRC1000 Front View)

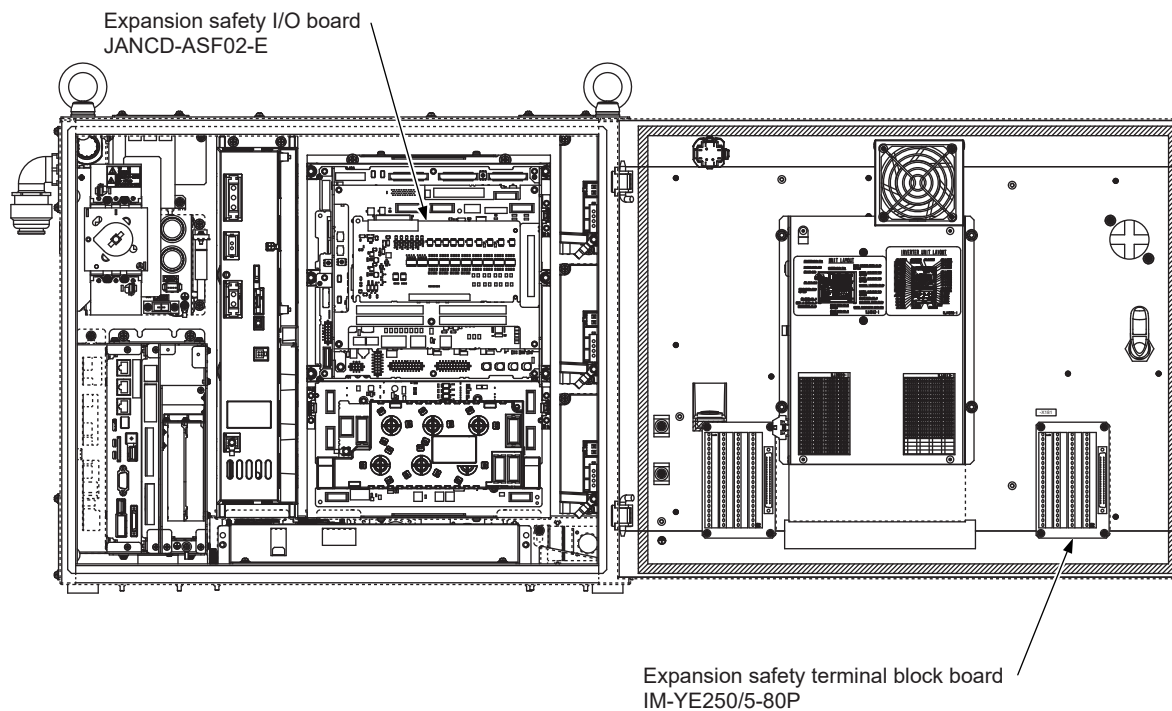

2.3 System Configuration for Dual-Arm Manipulator

Like dual-arm manipulator (SDA model) system, a system where the robot group (arm) and the base group (base) exist separately and individually arranged on the different servo board exists.

In this system, for the safety monitoring, the encoder feedback pulse information of the axis which does not exist in its own station should be acquired from other servo station. Thus, the following restrictions apply.



When using dual-arm type configuration manipulators, the maximum number of connecting axis for the servo station at the encoder data receiving side decreases.

Maximum numbers of connecting axis
= (9 axes - the number of axes whose encoder data was acquired from other servo station)

- 3 Common Operation
- 3.1 Security Mode When Using This Function

3 Common Operation

Common operations when using the functional safety function are described in this chapter.

3.1 Security Mode When Using This Function

When using the functional safety function, settings of the condition file for this function is necessary. And this settings must be performed when the security mode is in the safety mode. For this reason, this file settings must be performed by the person who has a safety license.

Followings are the procedures for changing the security mode.

1. Select {SYSTEM INFO} under the main menu, and then select {SECURITY} in the sub menu.

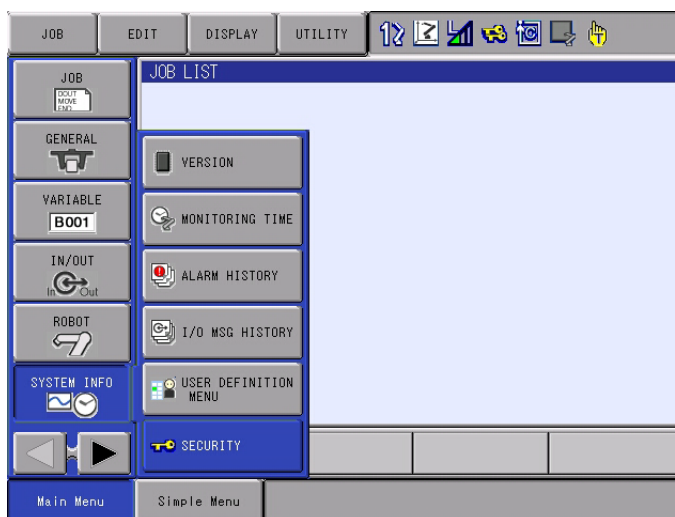

2. Change the security mode to the SAFETY MODE.
 - Press [SELECT], move the cursor to the SAFETY MODE, and press [SELECT] again.



3 Common Operation

3.1 Security Mode When Using This Function

3. Enter the password for the SAFETY MODE, and then press [ENTER].
 - The security mode is changed to the SAFETY MODE.

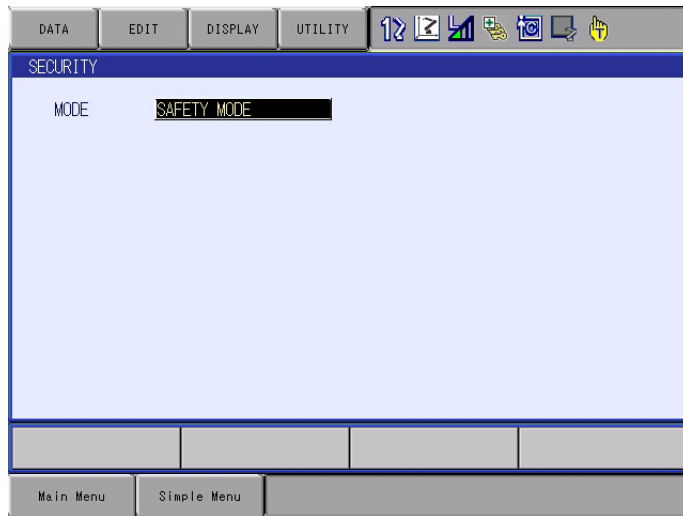

Depending on the level of the security mode, available operations are different as shown in the following table.

| Security level | Available operations |
|-----------------------------|---|
| Operation, Edit, Management | Only browsing of the data related to the functional safety is available. Editing is not available. |
| Safety | Both browsing and editing of the data related to the functional safety are available. |

- 3 Common Operation
- 3.2 Readback Operation

3.2 Readback Operation

When the functional safety is enabled and if data are modified in the condition file setting window or the tool file window of the functional safety, the readback operation is performed.

The readback operation is used to check whether the data to be set in the safety circuit board are correct.

3.2.1 Readback Operation of the Configuration File

The readback operation is performed for the configuration files in the settings window of the submenus shown below.

| Main menu | Submenu |
|-----------------|---------------------|
| ROBOT | TOOL |
| | TOOL INTERFERENCE |
| | HOME POSITIONING |
| SAFETY FUNCTION | AXIS RANGE LIMIT |
| | AXIS SPEED MONITOR |
| | ROBOT RANGE LIMIT |
| | SPEED LIMIT |
| | TOOL ANGLE MONITOR |
| | TOOL CHANGE MONITOR |
| | TOOL NUMBER SELECT |

1. Edit a file in the settings window of the data related to the functional safety.
After editing the data, {READBACK} and {CANCEL} appear in the lower part of the window.

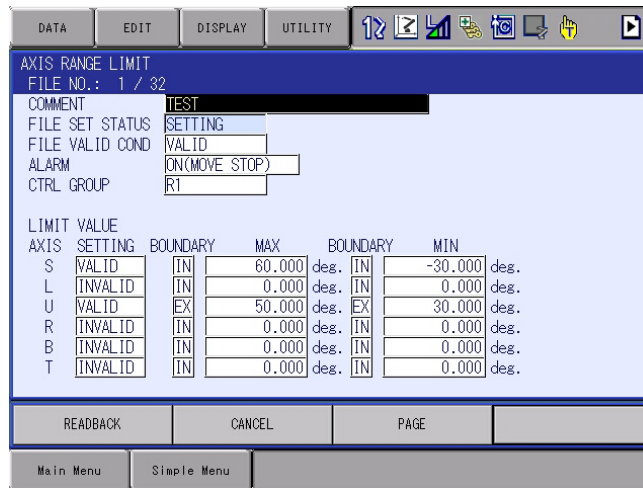

- {READBACK} : Transmits the settings of the edited file to the safety circuit board.
- {CANCEL} : Deletes the edited file and returns to the previous settings.

3 Common Operation

3.2 Readback Operation

2. To set the data of the edited file, press {READBACK}. By pressing {READBACK}, the data are transmitted to the safety circuit board, and {WRITE} and {CANCEL} appear in the lower part of the window.

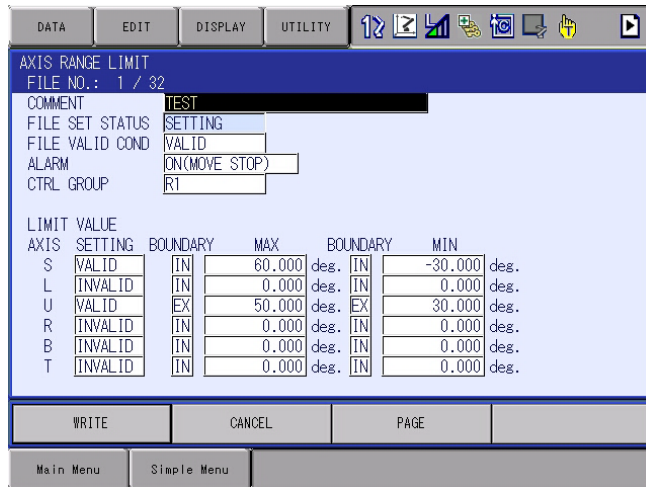

{WRITE} : Stores the settings of the edited file in the safety circuit board.

{CANCEL} : Deletes the edited file and returns to the previous settings.

3. To update the settings of the safety circuit board, press {WRITE}. By pressing {WRITE}, a confirmation dialog "Update the file?" appears.

- Select "YES", and if the data transmitted to the safety circuit board match the data in the edited file, the settings of the edited file are stored in the safety circuit board.
- Select "NO", and the settings of the file are not stored in the safety circuit board.

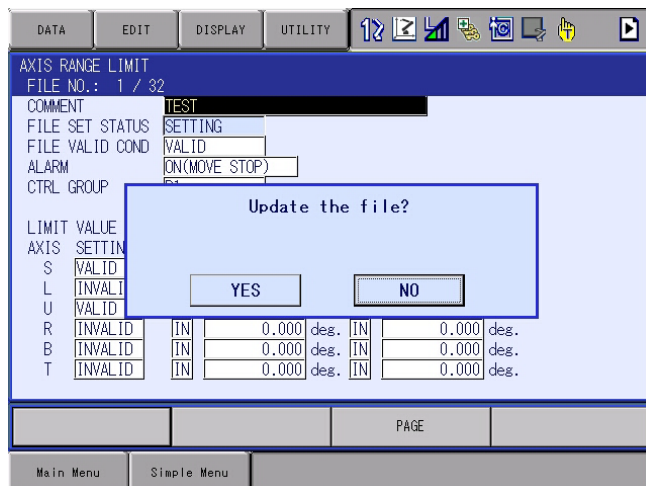

Note that the edited data will not be stored until {WRITE} is pressed and "YES" is selected in the confirmation dialog "Update the file?". The data will be deleted if the {WRITE} procedure is not completed in the following cases:

- When {CANCEL} is pressed
- When another menu is selected and its window is opened
- When the page is switched
- When the mode is switched
- When an alarm occurs

- 3 Common Operation
- 3.2 Readback Operation

3.2.2 Operations in Which the READBACK Window Is Shown

When one of the following items is edited, the READBACK window appears immediately after the edition, and the readback is performed.

| Window | Setting item |
|--------------------------|-----------------------|
| AXIS RANGE LIMIT | FUNCTION DISABLE MODE |
| ROBOT RANGE LIMIT | FUNCTION DISABLE MODE |
| TOOL ANGLE MONITOR | FUNCTION DISABLE MODE |
| TOOL CHANGE MONITOR | FUNCTION DISABLE MODE |
| TOOL NUMBER SELECT | FUNCTION DISABLE MODE |
| RANGE COMBINATION | INPUT FILE 1 |
| | INPUT FILE 2 |
| | LOGIC |
| | OUTPUT FILE |
| ROBOT INTERFERENCE MODEL | REFERENCE AXIS |
| | SPHERICAL RADIUS |
| | OFFSET<X> |
| | OFFSET<Y> |
| | OFFSET<Z> |

Only the readback operation is described here.

For the function disable mode, refer to *chapter 6.1 "Function Disable Mode Setting"*.

For the range combination function, refer to *chapter 4.3.9 "Combining Function of Multiple Monitoring Areas"*.

For the Robot Interference Model, refer to *chapter 4.3.10 "Extend Function of Robot Interference Model"*.

3 Common Operation
 3.2 Readback Operation

3.2.2.1 Readback Operation of the Function Disable Mode

Perform settings of FUNCTION DISABLE MODE in the STATUS listing window. In the following, the STATUS listing window of the axis range limit function is shown.

1. Select {SAFETY FUNCTION} under the main menu, and then select {AXIS RANGE LIMIT}. The STATUS listing window of AXIS RANGE LIMIT appears.

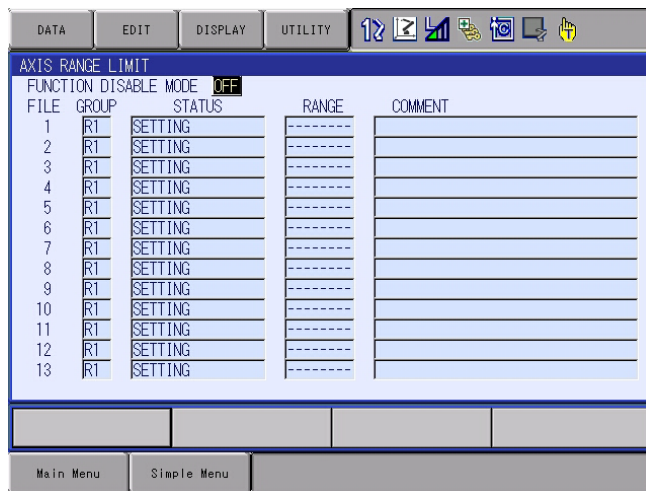

2. Select "ON(1)" under FUNCTION DISABLE MODE.

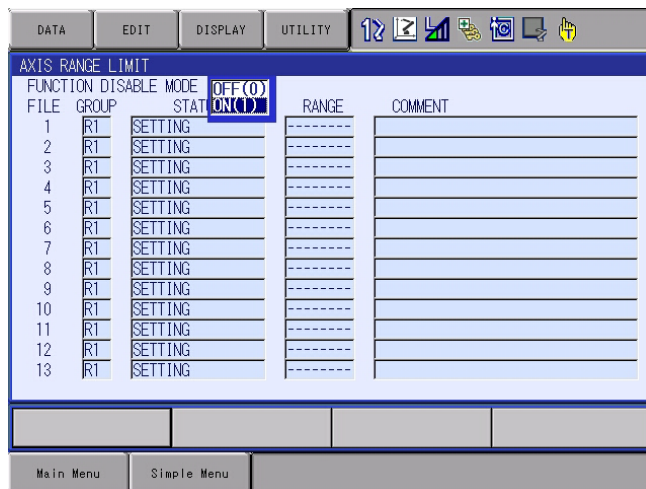

3 Common Operation

3.2 Readback Operation

3. The READBACK window appears.
 - The READBACK window is used to check whether the data to be set in the safety circuit board are correct.

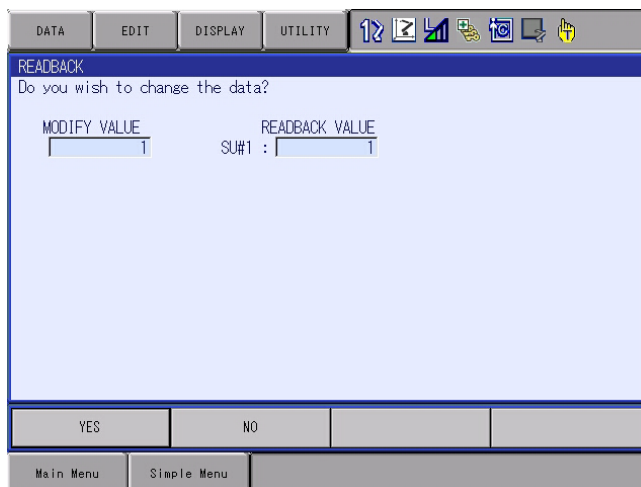

- Confirm the values in MODIFY VALUE and READBACK VALUE, and then press {YES}. If {NO} is pressed, the settings return to the previous values.
4. When {YES} is pressed, the settings are modified.

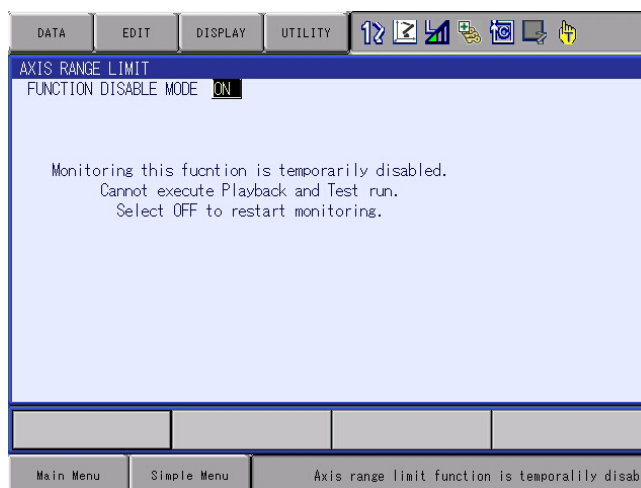

3.2.2.2 Readback Operation of the Range Combination

After editing settings of INPUT FILE 1, INPUT FILE 2, LOGIC, or OUTPUT FILE in the RANGE COMBINATION window, confirmation in the READBACK window is necessary.

After the readback operation, {WRITE} and {CANCEL} appear in the lower part of the window.

{WRITE} : Stores the settings of the edited file in the safety circuit board.

{CANCEL} : Cancels the settings of the edited file and returns to the previous settings.

When multiple setting items are modified, the readback operations are performed multiple times; however, those data will not be stored until {WRITE} is pressed. The data will be deleted if the {WRITE} procedure is not completed in the following cases:

- When {CANCEL} is pressed
- When another menu is selected and its window is opened
- When the mode is switched
- When an alarm occurs

3.2.2.3 Readback Operation of the Robot Interference Model

After editing settings of REFERENCE AXIS, SPHERICAL RADIUS, OFFSET<X>, OFFSET<Y>, or OFFSET<Z>, in the ROBOT INTERFERENCE MODEL window, confirmation in the READBACK window is necessary.

After the readback operation, {WRITE} and {CANCEL} appear in the lower part of the window.

{WRITE} : Stores the settings of the edited file in the safety circuit board.

{CANCEL} : Cancels the settings of the edited file and returns to the previous settings.

When multiple setting items are modified, the readback operations are performed multiple times; however, those data will not be stored until {WRITE} is pressed. The data will be deleted if the {WRITE} procedure is not completed in the following cases:

- When {CANCEL} is pressed
- When another menu is selected and its window is opened
- When the mode is switched
- When an alarm occurs

- 3 Common Operation
- 3.3 External Memory Device (Saving/Loading)

3.3 External Memory Device (Saving/Loading)

The files related to the functional safety can be saved to or loaded from an external memory device.

Saving of the files can be performed in any security mode.

Loading of the files can be performed only when the security mode is in the safety mode.

| File name | Security mode for loading |
|---|---------------------------|
| AXIS RANGE LIMIT DATA | Safety |
| AXIS SPEED MONITOR DATA | Safety |
| ROBOT RANGE DATA | Safety |
| SPEED LIMIT DATA | Safety |
| TOOL ANGLE MONITOR DATA | Safety |
| TOOL CHANGE MONITOR DATA (Common to TOOL NUMBER SELECT DATA) | Safety |
| APPR WARNING BUZZER DATA | Safety |

NOTE

When a file related to the functional safety is loaded, a message "Select 'Safety Board FLASH Reset' in the maintenance mode." appears.

For the details, please refer to *chapter 7.2 "FLASH Data Reset"*.

4 Details of Functional Safety Function

In this chapter, details of the functional safety function are described.

4.1 Axis Range Limit Function

4.1.1 Outline

Axis range limit function is a function which sets each axis range of motion for the manipulator, base and station group and monitors whether each axis is inside the already-fixed range of motion using a software.

This function specifies the upper limit and the lower limit of the range of motion to those axes and the range inside the limits is defined as the safety range.

While an axis is in operation, based on the axis motion speed, this function calculates the coasting value in case of the immediate stop by the alarm, and then, including this value, it monitors the safety range. With this monitoring operation, the axes would not exceed the safety range even if a motion error is detected.

In case an error is detected, the power supply to the motor is stopped using the machine safety. And the error is notified using an alarm.

Thirty two files are prepared to this function and all axes motion range of any one control group is set to one file. When a control group is set to several files, the control group can be monitored by switching conditions.

Fig. 4-1: Limit of Motion Range at Each Axis

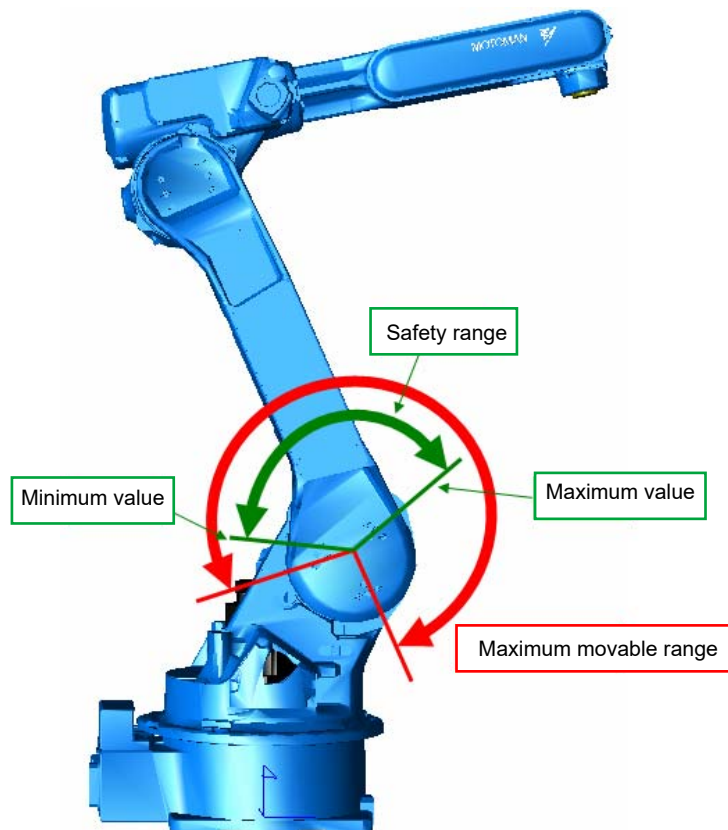

4 Details of Functional Safety Function
4.1 Axis Range Limit Function

Follow the procedures below when starting the axis range limit function.

1. Set the coasting value.
(Before using this function, set the coasting value by following the procedures described in *chapter 6.2 "External Axis Coasting Value Setting"* in case the base axis or the station axis exits in the system.)
2. Set the condition file of the axis range limit function.
3. Confirm the safety range.
4. Start the axis range limit function.

4 Details of Functional Safety Function
 4.1 Axis Range Limit Function

4.1.2 Axis Range Limit Function Window

Followings are the setting procedures for the axis range limit function.

1. Set the security mode to the safety mode, and then select {SAFETY FUNC.} under the main menu.

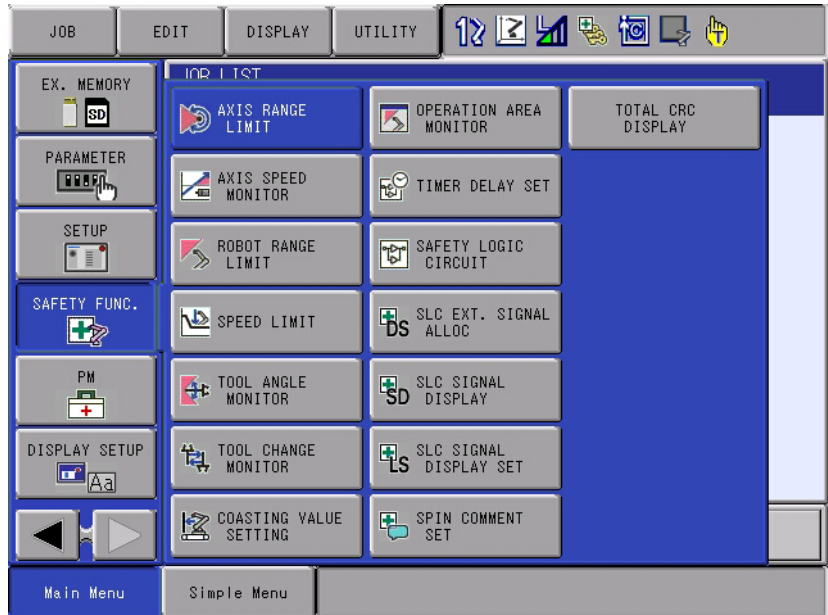

2. Select {AXIS RANGE LIMIT} in the sub menu.
 - The list of the axis range limit status appears.

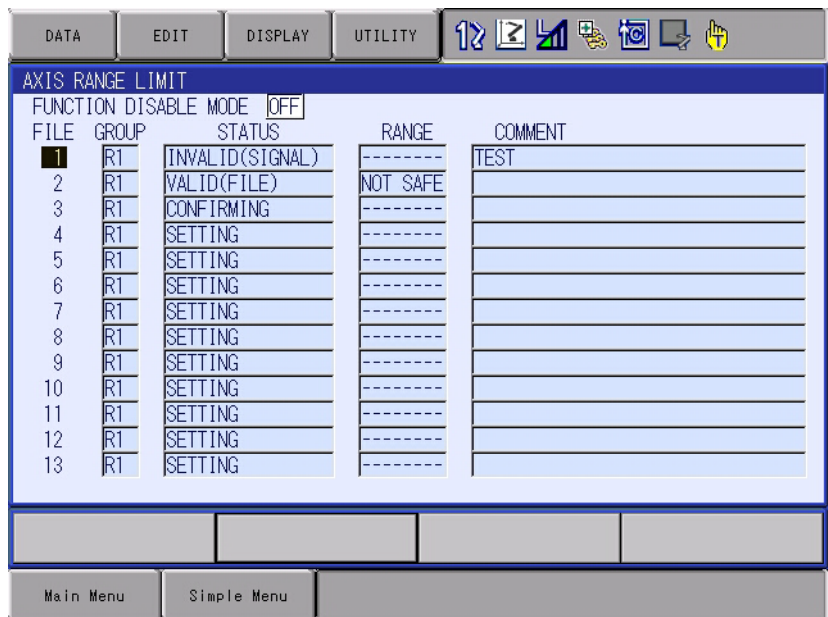

On the status list window, the 32 configuration files for the axis range limit function are arranged so that their status can be confirmed. By scrolling down the window, all the list can be seen.

Followings are the details of the item on the window.

4 Details of Functional Safety Function
4.1 Axis Range Limit Function

<Details of the Window>

1. FUNCTION DISABLE MODE

Valid/invalid the axis range limit function. When “ON” is selected, this function becomes invalid temporarily.

| Value | Description |
|-------|---|
| OFF | The axis range limit function is valid. |
| ON | The axis range limit function is invalid. The play back, test run, forward/backward operation become prohibited. |

For the details, please refer to *chapter 6.1 “Function Disable Mode Setting”*.

2. FILE

The number of the condition file is displayed.

Move the cursor to any number and press [SELECT]. The individual setting window for the selected condition file appears.

3. GROUP

The control group to be monitored specified by the condition file is indicated.

4. STATUS

Monitoring status of the present condition file is indicated.

| Value | Description |
|------------------|--|
| SETTING | The condition file is in the initial status or in the data setting status. Monitoring is not performed. |
| CONFIRMING | Confirming the area after the data is set. The status of the monitoring operation depends on the valid condition of the condition file. |
| VALID (FILE) | Data setting is completed and monitoring status of the file is in valid status. |
| INVALID (FILE) | Data setting is completed and monitoring status of the file is in invalid status. |
| VALID (SIGNAL) | Data setting is completed and monitoring status of the file is in valid status by the establishment of the safety signal condition. |
| INVALID (SIGNAL) | Data setting is completed and monitoring status of the file is in invalid status by the disestablishment of the safety signal condition. |

5. RANGE

Result of the present monitoring is displayed.

| Value | Description |
|----------|---|
| SAFE | Result of the object file monitoring is safe (inside the safety range). |
| NOT SAFE | Result of the object file monitoring is not-safe (outside the safety range) |
| - | The object file is in monitoring invalid status. |

6. COMMENT

The comment input is displayed.

4 Details of Functional Safety Function
 4.1 Axis Range Limit Function

4.1.3 Axis Range Limit Condition File Setting

On the status list window, select a file number with the cursor, and then press [SELECT].

- The settings window for the selected condition file of the axis range limit function appears.

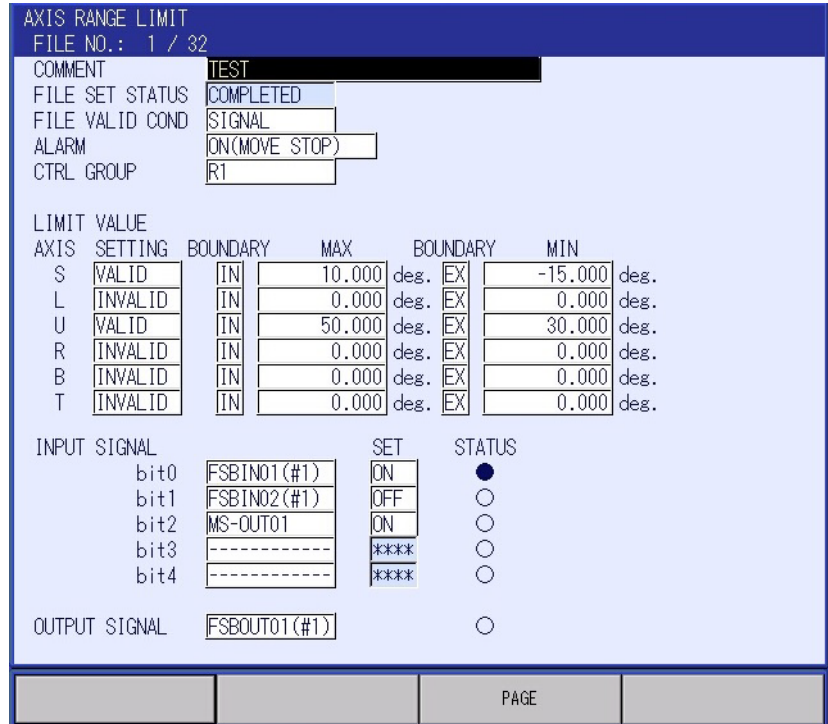

By scrolling down the window with the cursor, all the items can be seen.

<Details of the Window>

In this section, only the items inherent to the axis range limit function are explained. For the items not mentioned here, please refer to *chapter 4.8 "Common Setting Item for the Condition File"*.

1. AXIS

All the axis existing in a control group selected at {GROUP} item are indicated. (8 axes at maximum)

2. SETTING

To one object axis, validating/invalidating of the monitoring can be set. This setting is referred when the condition file is valid for monitoring, and is not referred when it is invalid for monitoring.

Followings show the combination of conditions.

| File monitoring status | Axis monitoring status | Result |
|------------------------|------------------------|---|
| Valid | Valid | Monitoring of the object axis is valid. |
| Valid | Invalid | Monitoring of the object axis is invalid. |
| Invalid | Valid | Monitoring of the object axis is invalid. |
| Invalid | Invalid | Monitoring of the object axis is invalid. |

4 Details of Functional Safety Function

4.1 Axis Range Limit Function

3. MAX, MIN

Values for maximum/minimum range of motion can be input for the object axis.

As their inputting range, with the axis's home position defined as 0, the position value limited by the soft limit switch of the manipulator can be input.

When the axis is a rotating axis, it is measured in [deg], and is [mm] when the axis is a direct acting axis.

| Value | Description |
|---------------|--|
| Minimum value | Expresses the limited range in which an axis moves in the negative direction. In case the following inequality is true, adding an positive value to the minimum value is possible. The minimum value < The maximum value |
| Maximum value | Expresses the limited range in which an axis moves in the positive direction. In case the following inequality is true, adding an negative value to the minimum value is possible. The minimum value < The maximum value |

To a T-axis or to a positioner to which an mechanical stopper is not equipped, there may be a case where an value which exceeds +360 [deg] can be input.

In this case, the maximum/minimum range are limited by the basis of numerical range but not by the basis of visual range.

For example, when 420 [deg] is set as the maximum value, the axis positions at 60 [deg] and 420 [deg] visually look as they are at the same position. However, even if the axis passed through the 60 [deg] position it will not be defined as an error and an error is detected when the axis reaches just before the 420 [deg] position.

Fig. 4-2: When the Axis Limit Value Exceeds ± 360 [deg]

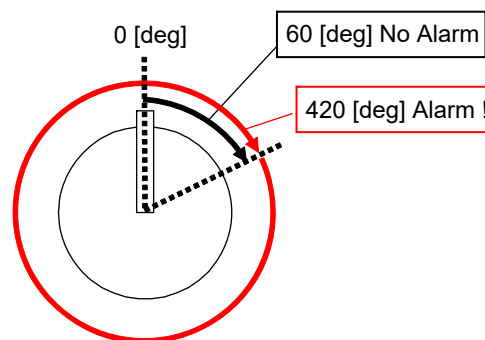

4 Details of Functional Safety Function
4.1 Axis Range Limit Function

4. BOUNDARY

Specifies whether the range of motion of the axis includes or excludes the maximum value and/or the minimum value.

The maximum value and the minimum value of each axis can be specified independently. To include the value in the range, select IN. To exclude the value from the range, select EX.

| Value | Description |
|-------|---|
| IN | Range of motion is set including the maximum/minimum value of the axis. <ul style="list-style-type: none">• When including the maximum value: (Range of motion of the axis \leq Maximum value)• When including the minimum value: (Minimum value \leq Range of motion of the axis) |
| EX | Range of motion is set excluding the maximum/minimum value of the axis. <ul style="list-style-type: none">• When excluding the maximum value: (Range of motion of the axis $<$ Maximum value)• When excluding the minimum value: (Minimum value $<$ Range of motion of the axis) |

4 Details of Functional Safety Function
 4.1 Axis Range Limit Function

4.1.4 Confirming Method of Each Axis Operating Angle

Each axis angle information can be confirmed on the CURRENT POSITION window.

Follow the procedures below when confirming the manipulator's present angle.

1. Set the security mode to the management mode or higher.
 Select {SETUP} under the main menu.

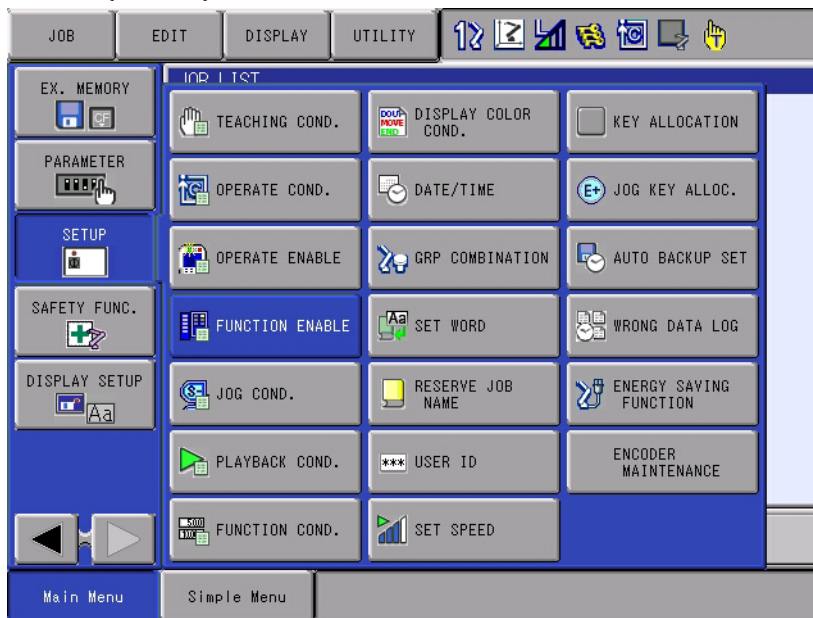

2. Select {FUNCTION ENABLE} in the sub menu.
 – The FUNCTION ENABLE SETTING window appears.

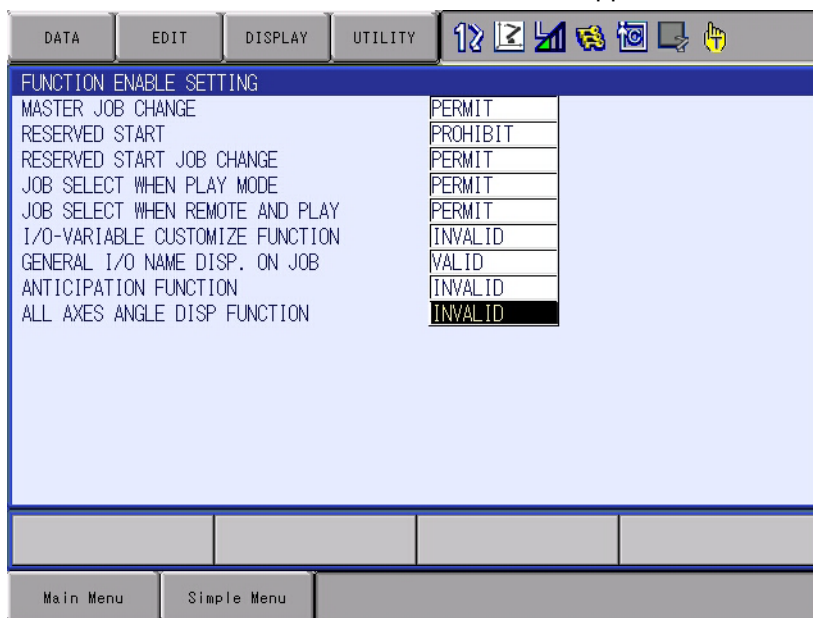

4 Details of Functional Safety Function
 4.1 Axis Range Limit Function

3. Set "VALID" to {ALL AXES ANGLE DISP FUNCTION}.

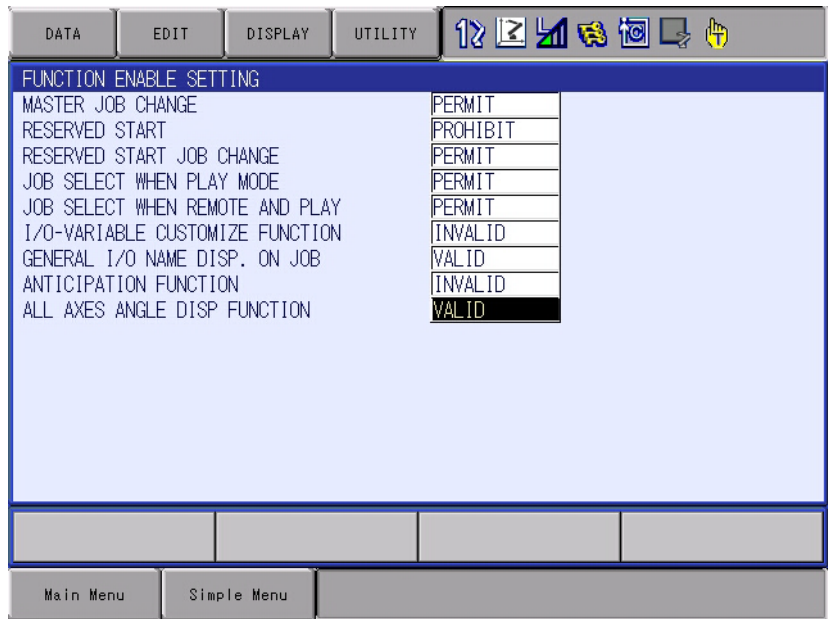

4. Select {ROBOT} under the main menu.

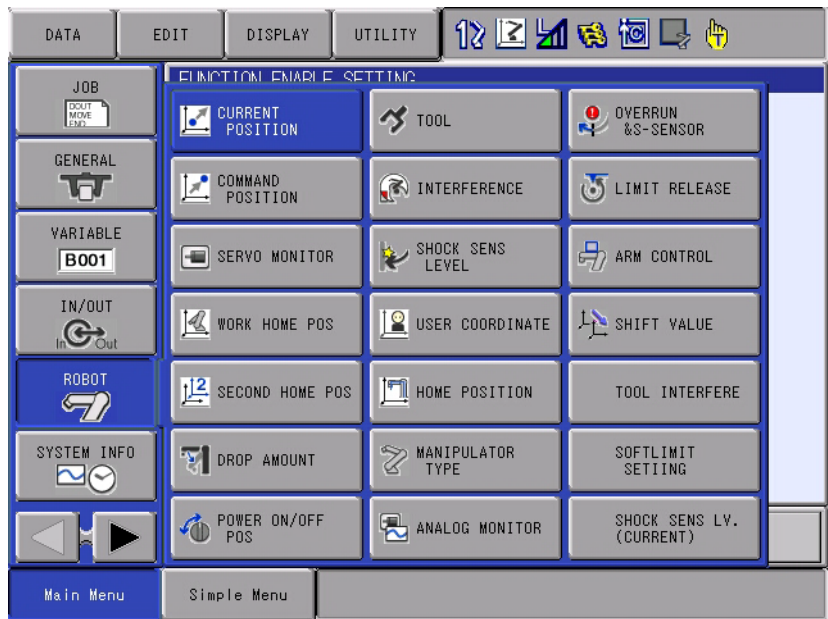

4 Details of Functional Safety Function
 4.1 Axis Range Limit Function

5. Select {CURRENT POSITION} in the sub menu.

– CURRENT POSITION window opens.

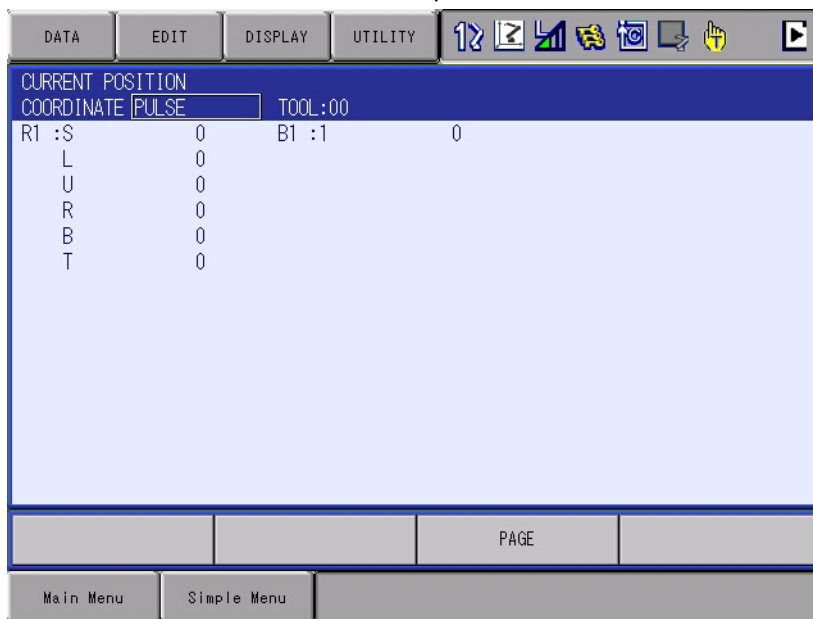

6. While CURRENT POSITION window is appeared, select {DISPLAY} tab at the upper left side of the window.

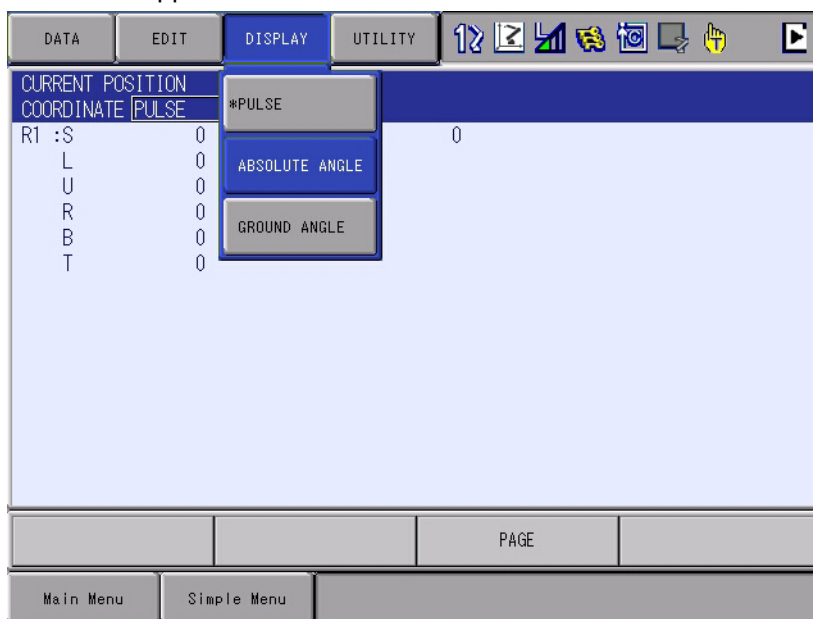

4 Details of Functional Safety Function

4.1 Axis Range Limit Function

7. Select {ABSOLUTE ANGLE} in the list under the {DISPLAY} tab.
- On {CURRENT POSITION} window, absolute angles of the axes which exist in the present system is displayed.

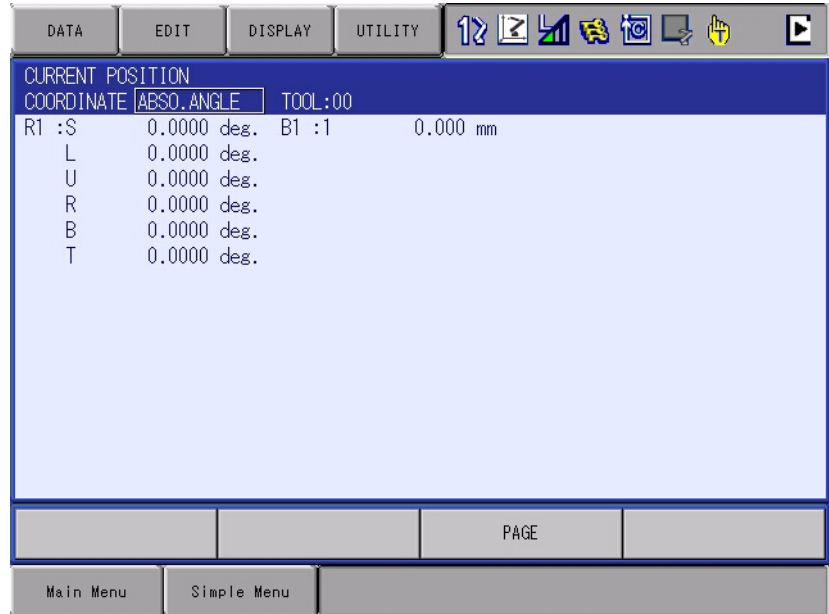

4 Details of Functional Safety Function

4.1 Axis Range Limit Function

4.1.5 Confirmation of Safety Range

Confirmation of the monitoring operation to be appropriately performed inside the specified safety range is required after values are set to both {MAX} and {MIN} and {WRITE} is executed.

“CONFIRMING” is indicated to the status of the condition file on the axis range limit window. Move the axes of the object group to confirm that they stop within the specified safety range.

When confirming the safety range, move the axes of the object group into the safety range, and then activate the monitoring operation of the condition file by either setting “VALID” for the FILE VALID COND or by inputting a selected safety signal to the condition file.

Fig. 4-3: Display When Confirming

| AXIS | SETTING | BOUNDARY | MAX | BOUNDARY | MIN |
|------|---------|----------|-------------|----------|------------|
| S | VALID | IN | 60.000 deg. | EX | 0.000 deg. |
| L | INVALID | IN | 0.000 deg. | EX | 0.000 deg. |
| U | INVALID | IN | 0.000 deg. | EX | 0.000 deg. |
| R | INVALID | IN | 0.000 deg. | EX | 0.000 deg. |
| B | INVALID | IN | 0.000 deg. | EX | 0.000 deg. |
| T | INVALID | IN | 0.000 deg. | EX | 0.000 deg. |



In the functional safety function, the range of motion is monitored by calculating the coasting values of the manipulator or the external axis. (Refer to *chapter 6.2 “External Axis Coasting Value Setting”*.) For this reason, the manipulator stops just before exceeding the safety range in case it moves to the teaching point near the safety range.

| | |
|-----|---------------------------------------|
| 4 | Details of Functional Safety Function |
| 4.1 | Axis Range Limit Function |

4.1.6 Start the Axis Range Limit Operation

After confirming that the object axis moves to reach the edge of the specified safety range, select {CONFIRM} on the window. "COMPLETE" appears in "FILE SET STAUTS", and the axis range limit can be performed.

Execute playback operation to confirm the manipulator's motion. An alarm may occur in case the teaching point or the settings are inappropriate.

When "Alarm 4780: F-SAFE AXIS RANGE LIMIT INTF" or "Alarm 4781: AXIS RANGE LIMIT INTF" appeared

<Cause>

The position of the axis is out of the safety range or a range of motion error is detected when the axis moved.

In the functional safety function, the axis position is monitored on the basis of the feedback pulse from the motor. In this case, taking the axis speed or coasting value into consideration, calculation of the movement is executed so that the manipulator would not come out from the safety range.

For this reason, in case a teaching point is set close to the edge of the safety range, and when the teaching speed is high, this alarm occurs.

<Countermeasure>

Confirm the safety range.

Modify the teaching point so that it moves not to close to the safety range border.

Decrease the manipulator's teaching speed when it passes by the border of the safety range.

4 Details of Functional Safety Function
 4.1 Axis Range Limit Function

4.1.7 Monitoring Status Confirmation Display

Settings of the configuration files (32 files) of the AXIS RANGE LIMIT can be checked as the list of the set values for each axis of the specified control group.

1. Select {SAFETY FUNC.} under the main menu, and then select {AXIS RANGE LIMIT}.

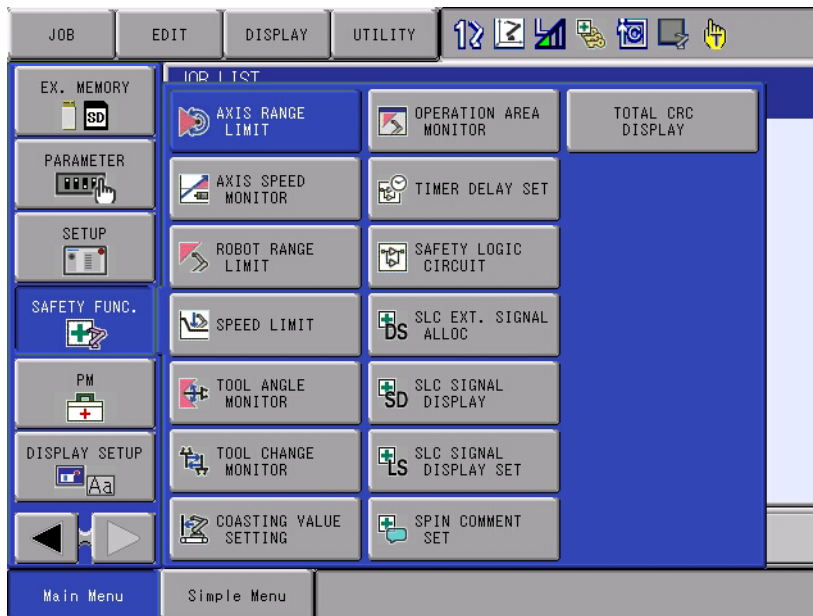

2. Select {DISPLAY}, and then select {MONITOR}.

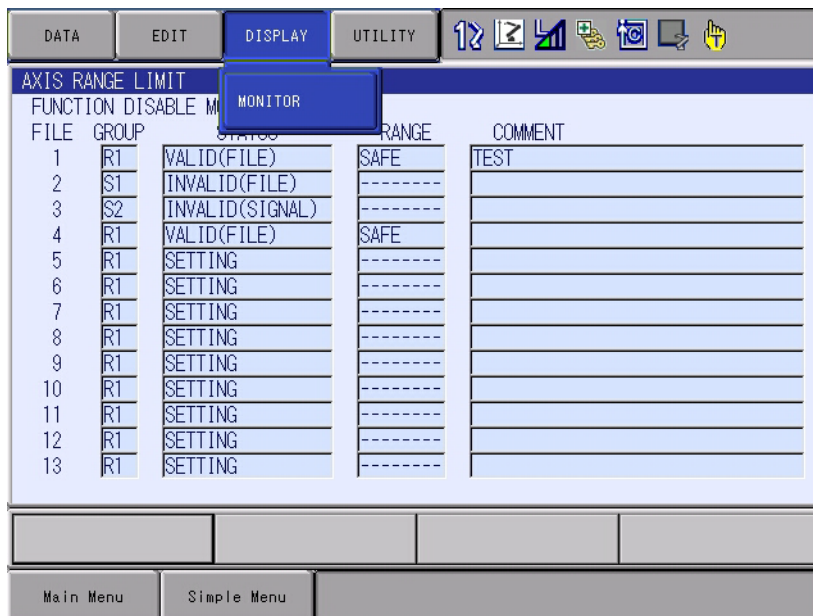

4 Details of Functional Safety Function

4.1 Axis Range Limit Function

3. The AXIS RANGE LIMIT MONITOR window appears.

- Scroll the window to the right to see the rest of the items.

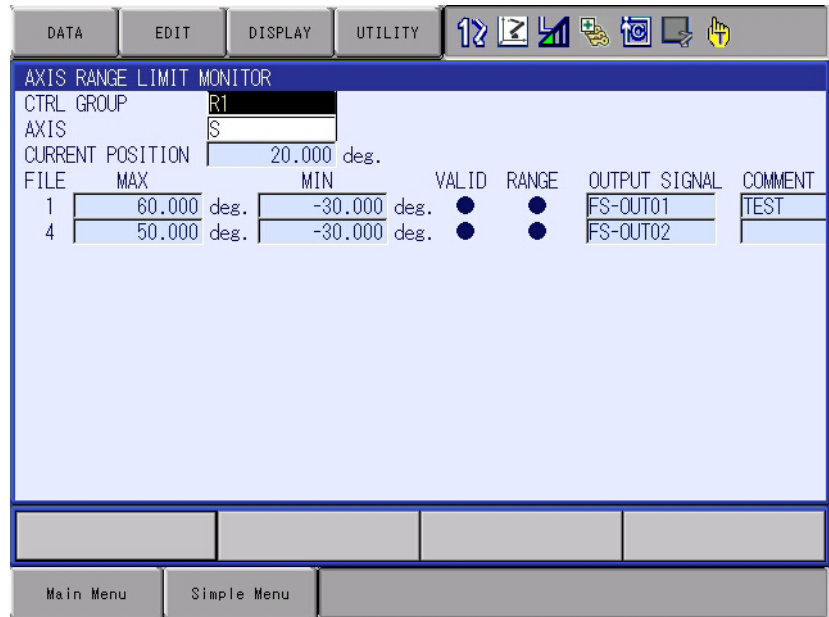

4. Items shown in the window are described below.

1. CTRL GROUP

Select the control group which includes the axis to be checked.

2. AXIS

Select the axis to be checked.

3. CURRENT POSITION

Indicates the manipulator's current position.

4. FILE

Indicates the file number for the axis range limit function.

5. MAX/MIN

Indicates the maximum/minimum value set for the file.

6. VALID

Indicates the monitoring status of the file. (○: invalid, ●: valid)

7. RANGE

Indicates whether the axis is located within the range set in the file.

(○: out of the range, ●: within the range)



WARNING

- This indication is not a safety signal. To confirm the safety status, make sure to use the safety output signal.

-
- 4 Details of Functional Safety Function
 - 4.1 Axis Range Limit Function
-

8. OUTPUT SIGNAL

Indicates the output signal set in the file.

9. COMMENT

Indicates the comment set in the file.

This window displays only the file(s) in which the selected axis is set as "valid". If no file for the axis range limit function is set, this window displays nothing.

4.2 Axis Speed Monitor Function

4.2.1 Outline

Axis speed monitor function is a function which sets the upper limit of the speed to each axis motion speed for the manipulator, base and station group, and then monitors whether each axis is inside the already-fixed speed using a software. When “0” is set, it is called stop position monitoring. This monitors the axis whether it does not move to exceed the limit of specified range from the point where the monitoring is started.

In case an error is detected, the power supply to the motor is stopped using the machine safety. And the error is notified using an alarm.

Thirty two files are prepared to this function and all axes motion range of any one control group is set to a file. When a control group is set to several files, the control group can be monitored by switching conditions.

Fig. 4-4: Monitoring of Motion Speed at Each Axis

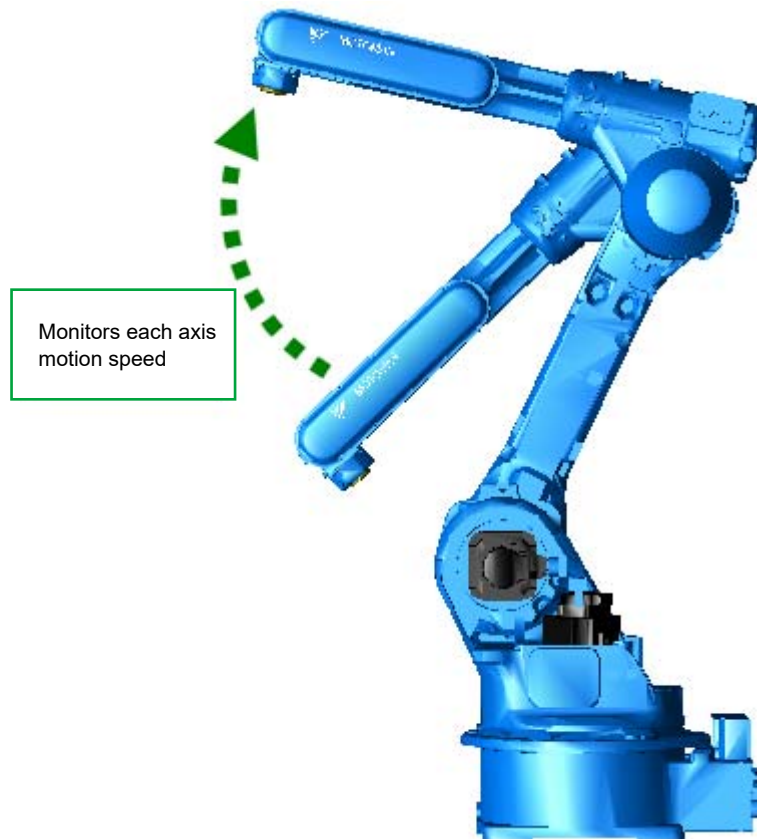

Follow the procedures below when starting the axis speed monitor function.

1. Set the axis speed monitor condition file.
2. Start monitoring the axis speed.

4 Details of Functional Safety Function
 4.2 Axis Speed Monitor Function

4.2.2 Axis Speed Monitor Function Window

Followings are the setting procedures for the axis speed monitor function.

1. Set the security mode to the safety mode, and then select {SAFETY FUNC.} under the main menu.

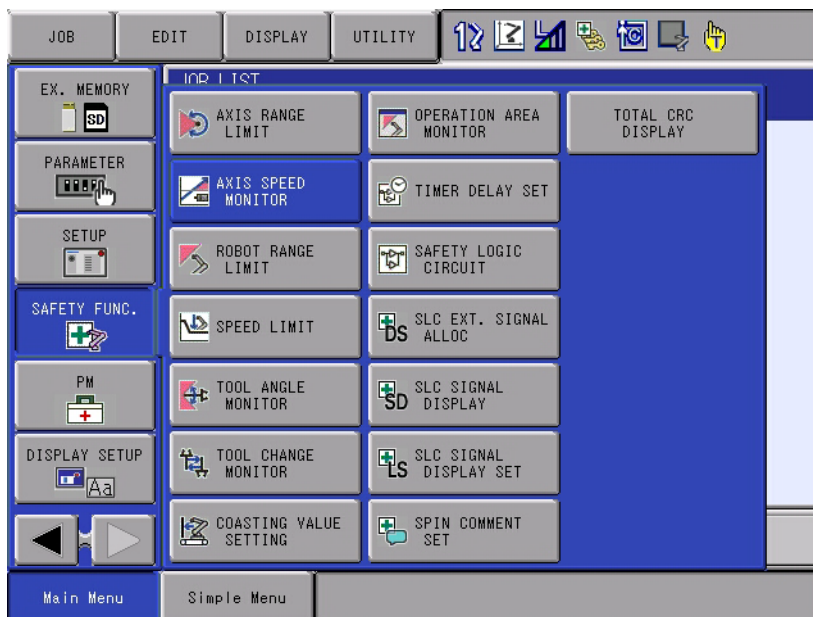

2. Select {AXIS SPEED MONITOR} in the sub menu.
 - The list of the axis speed monitor status appears.

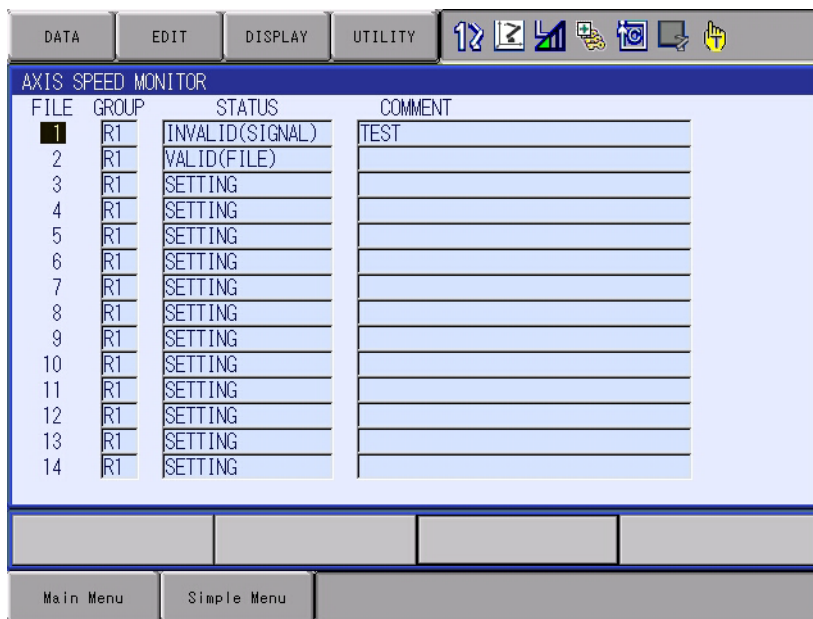

On the status list window, the 32 configuration files for the axis speed limit function are arranged so that their status can be confirmed. By scrolling down the window, all the list can be seen.

4 Details of Functional Safety Function
 4.2 Axis Speed Monitor Function

Followings are the details of the item on the window.

<Details of the Window>

1. FILE

The number of the condition file is displayed.

Move the cursor to any number and press [SELECT]. The individual setting window for the selected condition file appears.

2. GROUP

The control group to be monitored set by the condition file

3. STATUS

Monitoring status of the present condition file

| Value | Description |
|------------------|--|
| SETTING | The condition file is in the initial status or in the data setting status. Monitoring is not performed. |
| VALID (FILE) | Data setting is completed and monitoring status of the file is in valid status. |
| INVALID (FILE) | Data setting is completed and monitoring status of the file is in invalid status. |
| VALID (SIGNAL) | Data setting is completed and monitoring status of the file is in valid status by the establishment of the safety signal condition. |
| INVALID (SIGNAL) | Data setting is completed and monitoring status of the file is in invalid status by the disestablishment of the safety signal condition. |

4. COMMENT

The comment input is displayed.

4 Details of Functional Safety Function
 4.2 Axis Speed Monitor Function

4.2.3 Axis Speed Monitor Condition File Setting

On the status list window, select a file number with the cursor, and then press [SELECT].

- The settings window for the selected condition file of the axis speed monitor function appears.

<When the unit of the speed is deg/sec>

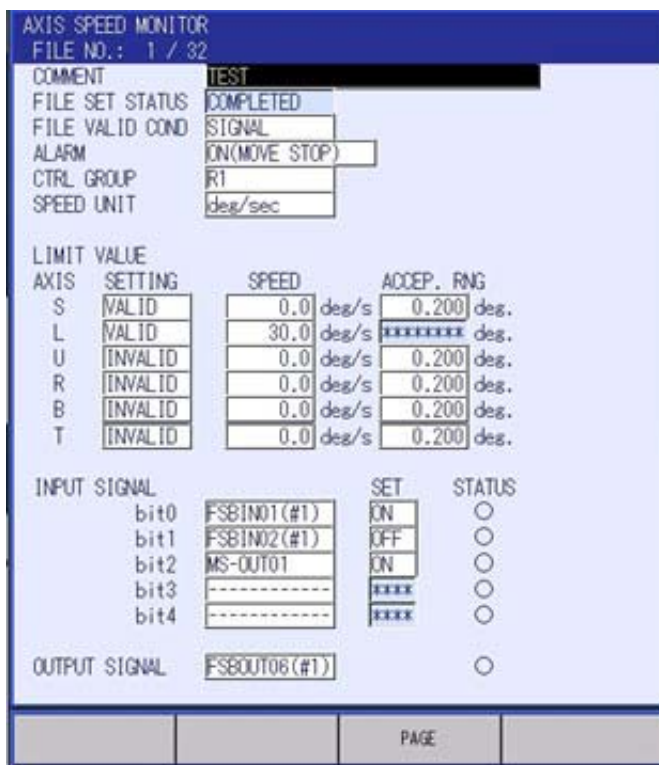

<When the unit of the speed is %>

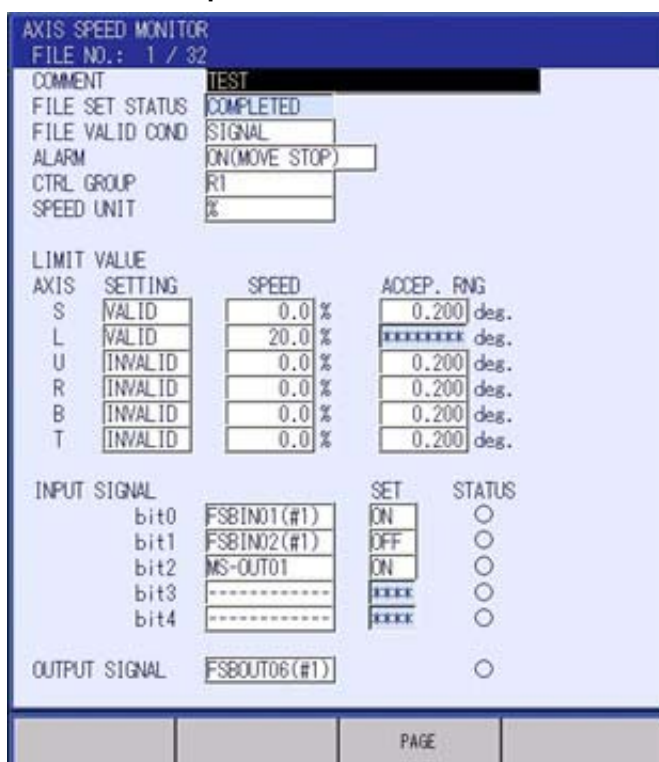

By scrolling down the window with the cursor, all the items can be seen.

4 Details of Functional Safety Function

4.2 Axis Speed Monitor Function

<Details of the Window>

In this section, only the items inherent to AXIS SPEED MONITOR are explained. For the items not mentioned here, please refer to *chapter 4.8 "Common Setting Item for the Condition File"*.

1. AXIS

All the axis existing in a control group selected at {GROUP} item.

2. SETTING

To one objective axis, validating/invalidating of the monitoring can be set.

This setting is referred when the condition file is valid for monitoring, and is not referred when it is invalid for monitoring.

Followings show the combination of conditions.

| File monitoring status | Axis monitoring status | Result |
|------------------------|------------------------|---|
| Valid | Valid | Monitoring of the object axis is valid. |
| Valid | Invalid | Monitoring of the object axis is invalid. |
| Invalid | Valid | Monitoring of the object axis is invalid. |
| Invalid | Invalid | Monitoring of the object axis is invalid. |

3. Unit of the speed

The unit of the speed can be specified in the settings file.

When "deg/s" is set as the unit of the speed, [deg/sec] is used for a rotating axis, and [mm/sec] is used for a linear-motion axis.

When "%" is set as the unit of the speed, percentage is used.

4. SPEED

To each object axis, set the upper limit of motion speed.

When "deg/s" is set as the unit of the speed, [deg/sec] is used for a rotating axis, and [mm/sec] is used for a linear-motion axis.

When "%" is set as the unit of the speed, calculate and set the upper limit by considering the maximum speed as 100%. This unit [%] is the same as the unit of the set value used when the object axis is independently operated by MOVJ=xx%.

5. ACCEP. RNG

When "0" is set to {SPEED}, setting a value to this item becomes possible.

This item is used when the axis is in the stop position monitoring status. The stop position monitoring operation judges that the axis is not moving by monitoring the object axis position difference between the stop position monitoring starting position and the present position.

To avoid any alarms from occurring due to tiny motions such as turning ON of the servo during the monitoring, this item is set.

An alarm occurs when {ACCEP.RNG} is set in \pm direction from the stop position monitoring starting position and the axis moves to exceed the position.

When the axis is a rotating axis, the unit is [deg], and when the axis is a linear-motion axis, the unit is [mm].

-
- 4 Details of Functional Safety Function
 - 4.2 Axis Speed Monitor Function
-

4.2.4 Start the Axis Speed Monitor Operation

After values are input to "SPEED" and {WRITE} on the window is selected, "COMPLETED" appears in "FILE SET STATUS". After that, the axis speed monitor can be performed.

4.3 Robot Range Limit Function

4.3.1 Outline

The robot range limit function is a function which carries out following monitoring using software.

1. Define the manipulator's range of motion with polygonal prism or cuboid, and then monitors the manipulator arm or its tool to be inside the range of motion.
→Inside the range monitoring
2. Define the manipulator's approach-prohibited area with polygonal prism or cuboid, and then monitors whether the manipulator arm or its tool does not move inside the area.
→Outside the range monitoring
3. Limit the manipulator's range of motion with a large enough plane (wall), and then monitors the manipulator arm or its tool so as not to interfere with the plane.
→Planar interference monitoring

<Inside the range monitoring>

The manipulator's range of motion can be defined using the prism from triangular prism to 16-prisms. The space inside the prism is defined as the safety range.

There are two ways of specifying the prism as follows:

- A polygon on the XY plane with a height in Z-axis direction.
- A cuboid consists of two points on a diagonal line.

When the result of the monitoring is safe, the object arm and the tool of the manipulator are inevitably inside the safety range.

Fig. 4-5: Inside the Range Monitoring

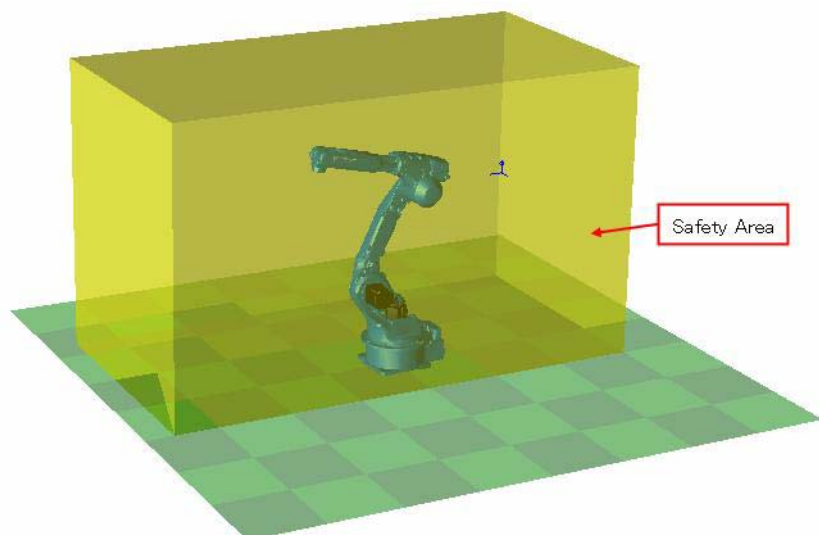

4 Details of Functional Safety Function
 4.3 Robot Range Limit Function

<Outside the range monitoring>

The manipulator's range of motion can be defined using the prism with triangular prism and quadrangular prism. The space outside the prism is defined as the safety range.

There are two ways of specifying the prism as follows.

-A polygon on the XY plane with a height in Z-axis direction.

-A cuboid consists of two points on a diagonal line.

When the result of the monitoring is safe, the object arm and tool of the manipulator are inevitably outside the safety range.

Fig. 4-6: Outside the Range Monitoring

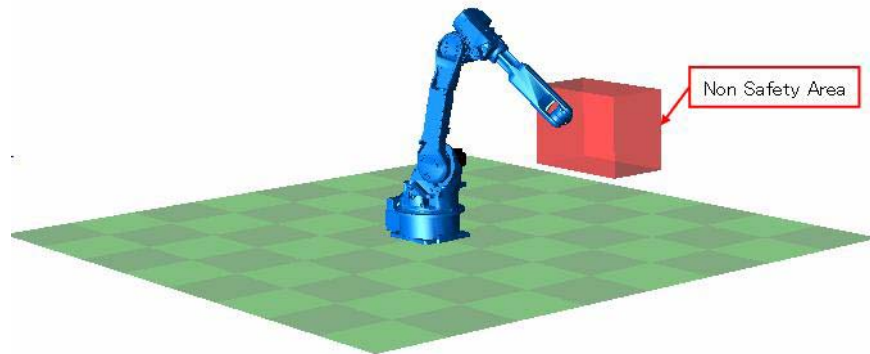

<Planar interference monitoring>

Draw a line on either XY, YZ or ZX coordinate plane, and then, along the line, set a plane (wall) in the vertical direction. A plane, which is large enough to the manipulator, is specified. Regarding the plane as a boarder, the area where the manipulator exists is defined as the safety range. The plane is defined by specifying a coordinate plane and two points for drawing a line.

Fig. 4-7: Outside the Range Monitoring

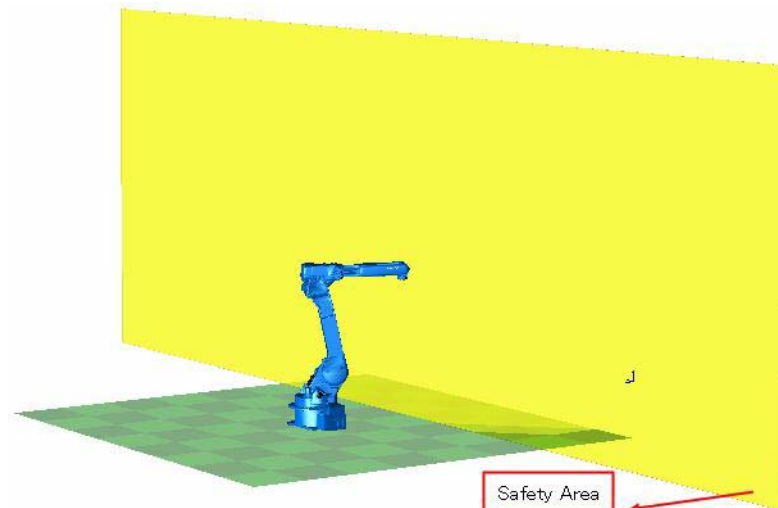

4 Details of Functional Safety Function

4.3 Robot Range Limit Function

While a manipulator is in operation, based on the manipulator motion speed, this function calculates the coasting value in case of the immediate stop by the alarm, and then, including this value, this function monitors the safety range. With this monitoring operation, the axes would not exceed the safety range even if a motion error is detected.

In case an error is detected, the power supply to the motor is stopped using the machine safety. And the error is notified using an alarm.

Thirty two files are prepared to this function and any one control group and a safety range is set to a file. When a control group is set to several files, the control group can be monitored by switching conditions.

Follow the procedures below when starting the robot range limit function.

1. Set the coasting value.
(Before using this function, set the coasting value by following the procedures described in *chapter 6.2 "External Axis Coasting Value Setting"* in case the base axis or the station axis exits in the system.)
2. Set the tool file.
(Before using this function, execute tool file setting by referring to *chapter 6.3 "Tool File Setting"* .)
3. Set the tool interference file.
(Before using this function, execute tool interference file setting by referring to *chapter 6.4 "Tool Interference File Setting"* .)
4. Set the robot range limit function.
5. Confirm the safety range.
6. Start the robot range limit function.

4 Details of Functional Safety Function
 4.3 Robot Range Limit Function

4.3.2 Robot Range Limit Function Window

Followings are the setting procedures for the axis range limit function.

1. Set the security mode to the safety mode, and then select {SAFETY FUNC.} under the main menu.

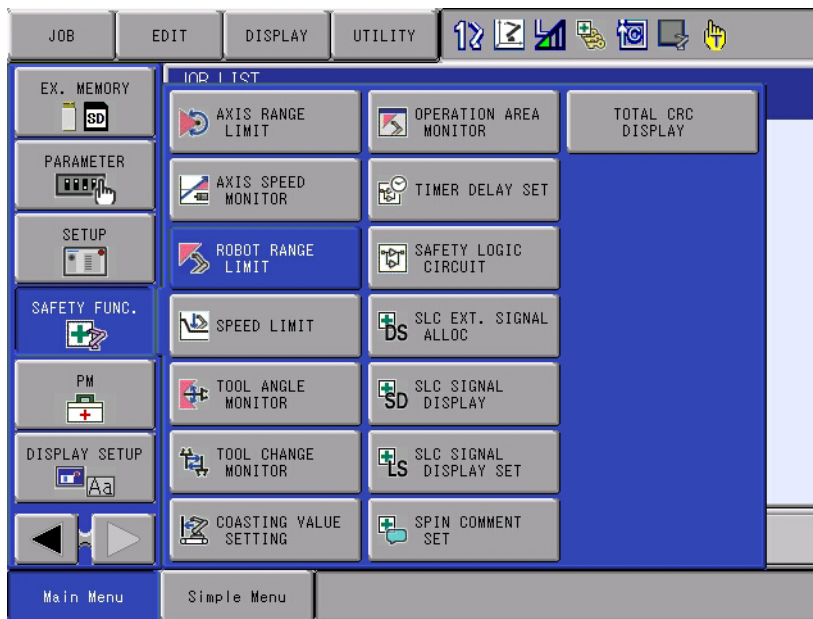

2. Select {ROBOT RANGE LIMIT} in the sub menu.
 – The list of the robot range limit status appears.

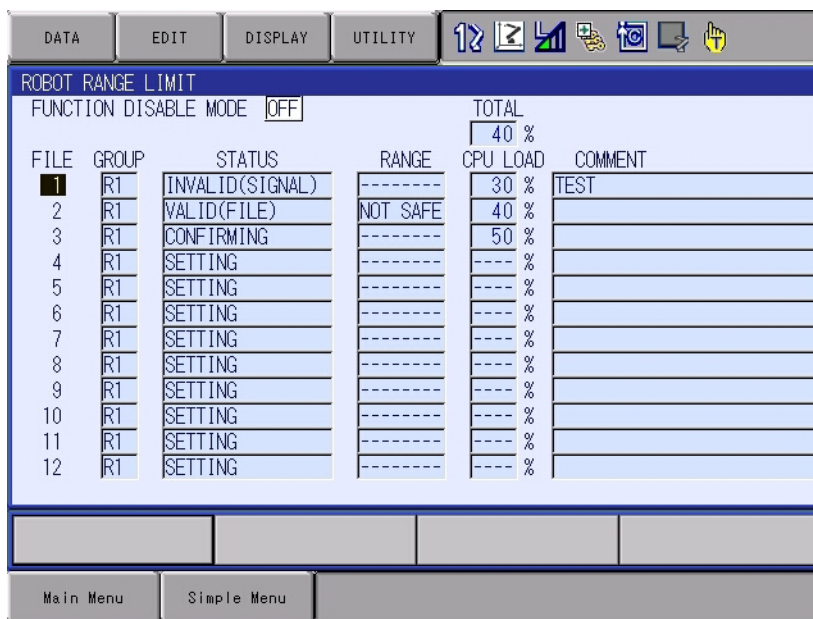

On the status list window, the 32 configuration files for the axis range limit function are arranged so that their status can be confirmed. By scrolling down the window, all the list can be seen.

4 Details of Functional Safety Function

4.3 Robot Range Limit Function

Followings are the details of the item on the window.

<Details of the Window>

1. FUNCTION DISABLE MODE

Valid/invalid the robot range limit function. When "ON" is selected, the condition files of the 32 files of this function can be set to invalid temporarily.

| Value | Description |
|-------|--|
| OFF | The robot range limit function is valid. |
| ON | The robot range limit function is invalid. The play back, test run, forward/backward operation become prohibited. |

For the details, please refer to *chapter 6.1 "Function Disable Mode Setting"*.

2. FILE

The number of the condition file is displayed.

Move the cursor to any number and press [SELECT]. The individual setting window for the selected condition file appears.

3. GROUP

The control group to be monitored specified by the condition file is indicated.

4. STATUS

Monitoring status of the present condition file is indicated.

| Value | Description |
|------------------|--|
| SETTING | The condition file is in the initial status or in the data setting status. Monitoring is not performed. |
| CONFIRMING | Confirming the area after the data is set. The status of the monitoring operation depends on the valid condition of the condition file. |
| VALID (FILE) | Data setting is completed and monitoring status of the file is in valid status. |
| INVALID (FILE) | Data setting is completed and monitoring status of the file is in invalid status. |
| VALID (SIGNAL) | Data setting is completed and monitoring status of the file is in valid status by the establishment of the safety signal condition. |
| INVALID (SIGNAL) | Data setting is completed and monitoring status of the file is in invalid status by the disestablishment of the safety signal condition. |

5. RANGE

Result of the present monitoring is displayed.

| Value | Description |
|----------|--|
| Safe | Result of the object file monitoring is safe (inside the safety range) is safe (inside the safety range) |
| Not-safe | Result of the object file monitoring is not-safe (outside the safety range) |
| - | The object file is in monitoring invalid status. |

- 4 Details of Functional Safety Function
- 4.3 Robot Range Limit Function

6. CPU LOAD

The robot range limit function can, to some extent, freely define the shape as its range of motion. However, the time period needed for processing the monitoring varies depending on the shape or the method of monitoring.

Regard the allocated processing time for robot range limit function as 100%, the ratio of necessary processing time for the area created in the object area is indicated to this item.

Followings are processing time for each area created in the object area.

| Monitoring method | Numbers of point | Processing time |
|-------------------|------------------|-----------------|
| Inside the area | 4 | 20% |
| | 8 | 23% |
| | 16 | 30% |
| Outside the area | 3 | 18% |
| | 4 | 20% |
| | 4 (Cuboid) | 18% |
| Plane (X-Y) | - | 8% |
| Plane (Y-Z) | - | 8% |
| Plane (X-Z) | - | 8% |

7. TOTAL

Total {CPU LOAD} of the files to which monitoring is validated.



When executing the robot range limit function even after the total cpu load exceeded over 100%, following alarms may occur due to insufficient processing time.

Alarm 500 SEGMENT PROC NOT READY

Alarm 1899 F-SAFE MONITOR EXECUTE TIMEOVER

When an alarm occurred, reduce the area where the monitoring is simultaneously validated to avoid the cpu load from exceeding 100%.

8. COMMENT

The comment input is displayed.

4 Details of Functional Safety Function
 4.3 Robot Range Limit Function

4.3.3 Robot Range Limit Function Condition File Setting Window

On the status list window, select a file number with the cursor, and then press [SELECT].

A setting window for the selected condition file of the ROBOT RANGE LIMIT function appears.

On this window, the indication pattern on the window changes depending on the selection of {MONITOR TARGET} or {SHAPE TYPE}. For the details of the indication, please refer to the table below.

| MONITOR TARGET | SHAPE TYPE | Indication |
|---------------------------|------------|------------|
| INSIDE, OUTSIDE | PRISM | Pattern A |
| | CUBOID | Pattern B |
| Plane (X-Y), (Y-Z), (X-Z) | - | Pattern C |

■ Pattern A

Following is the pattern A of the indication of condition file setting window.

By scrolling down the window with the cursor, all the indication can be seen.

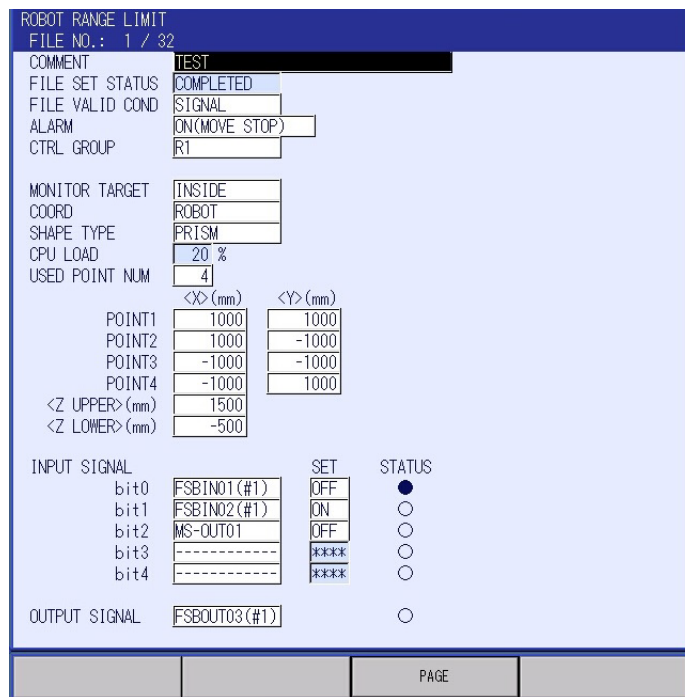

On this window, the polygonal prism is defined with the following two steps.

STEP 1: Define a polygonal prism on the X-Y plane.

STEP 2: Specify 2 points on the Z-axis to define them as the height for the polygonal prism on the X-Y plane.

4 Details of Functional Safety Function

4.3 Robot Range Limit Function

Fig. 4-8: Image of Robot Limit Range: Pattern A

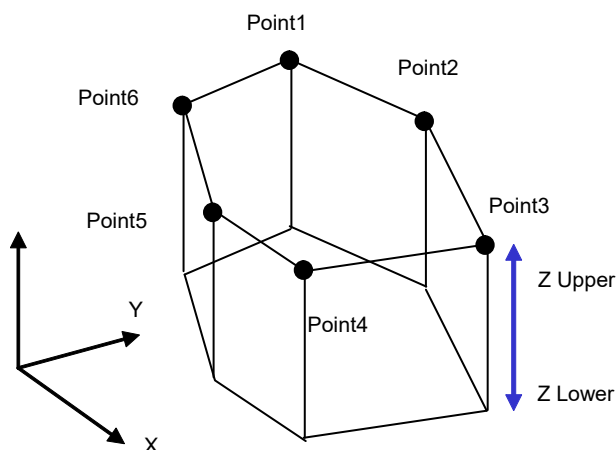

<Details of the Window>

In this section, only the items inherent to robot range limit functions are explained. For the items not mentioned here, please refer to *chapter 4.8 "Common Setting Item for the Condition File"*.

1. MONITOR TARGET

To the area of the object file, set the monitoring method.

| Value | Method |
|-------------|--|
| INSIDE | Set the inside range monitoring. |
| OUTSIDE | Set the outside range monitoring. |
| Plane (X-Y) | Set the planar interference monitoring (X-Y) |
| Plane (Y-Z) | Set the planar interference monitoring (Y-Z) |
| Plane (X-Z) | Set the planar interference monitoring (X-Z) |

2. COORD

Specify the coordinates system to be monitored.

| Value | Method |
|-------|--|
| ROBOT | Define the monitoring area on the robot Cartesian coordinate system. |
| BASE | Define the monitoring area on the base Cartesian coordinate system. |

4 Details of Functional Safety Function
 4.3 Robot Range Limit Function

Setting Example of Coordinate “Robot”: When setting the area shown in fig. 4-9 “Area Setting (Robot)” .

Fig. 4-9: Area Setting (Robot)

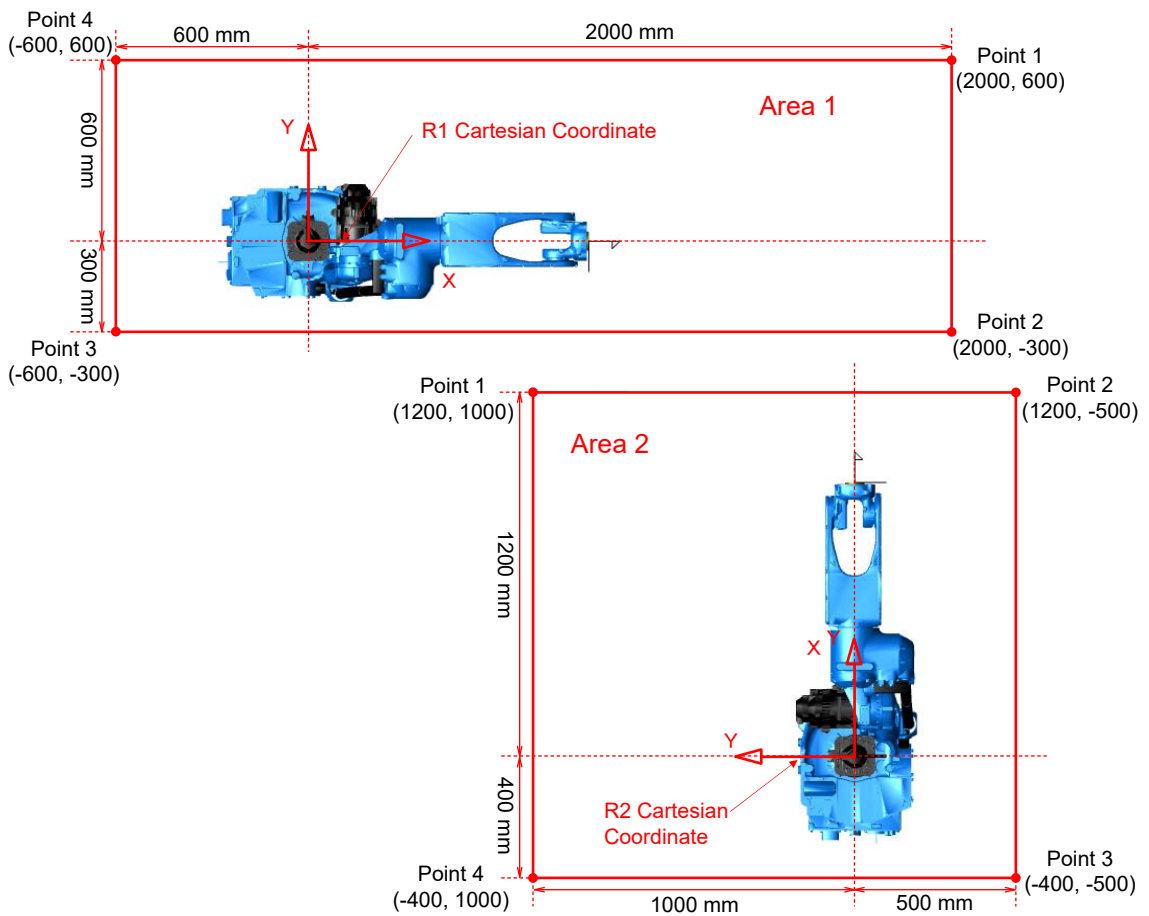

For the area 1, as shown in fig. 4-10 “Example of Condition File Setting (R1: Robot)”, select R1 to CTRL GROUP and ROBOT to COORD. Also, to each POINT, set positions which are on the R1 Cartesian coordinates.

For the area 2, as shown in fig. 4-11 “Example of Condition File Setting (R2: Robot)”, select R2 to CTRL GROUP and ROBOT to COORD. Also, to each POINT, set each position which are on the R2 Cartesian coordinates.

Fig. 4-10: Example of Condition File Setting (R1: Robot)

| | | |
|----------------|----------|----------|
| CTRL GROUP | R1 | |
| MONITOR TARGET | INSIDE | |
| COORD | ROBOT | |
| SHAPE TYPE | PRISM | |
| CPU LOAD | 20 % | |
| USED POINT NUM | 4 | |
| | <X> (mm) | <Y> (mm) |
| POINT1 | 2000 | 600 |
| POINT2 | 2000 | -300 |
| POINT3 | -600 | -300 |
| POINT4 | -600 | 600 |
| <Z UPPER> (mm) | 0 | |
| <Z LOWER> (mm) | 0 | |

Fig. 4-11: Example of Condition File Setting (R2: Robot)

| | | |
|----------------|----------|----------|
| CTRL GROUP | R2 | |
| MONITOR TARGET | INSIDE | |
| COORD | ROBOT | |
| SHAPE TYPE | PRISM | |
| CPU LOAD | 20 % | |
| USED POINT NUM | 4 | |
| | <X> (mm) | <Y> (mm) |
| POINT1 | 1200 | 1000 |
| POINT2 | 1200 | -500 |
| POINT3 | -400 | -500 |
| POINT4 | -400 | 1200 |
| <Z UPPER> (mm) | 0 | |
| <Z LOWER> (mm) | 0 | |

4 Details of Functional Safety Function

4.3 Robot Range Limit Function

When setting a position to a POINT, confirm the position following the procedures below.

1. Select {ROBOT} → {CURRENT POSITION} under the main menu.
 - The CURRENT POSITION window appears.

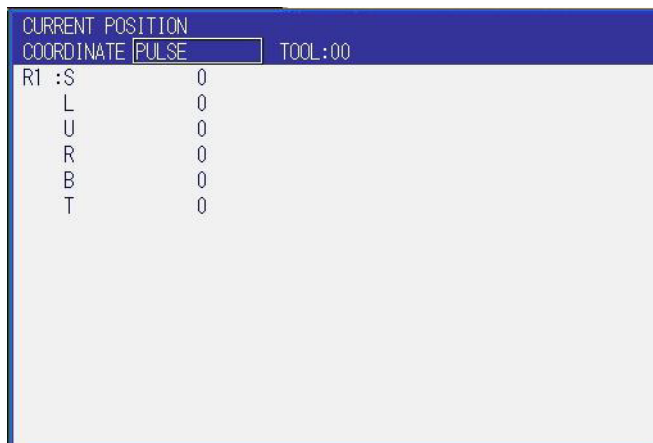

2. Select {ROBOT} at {COORDINATE}.

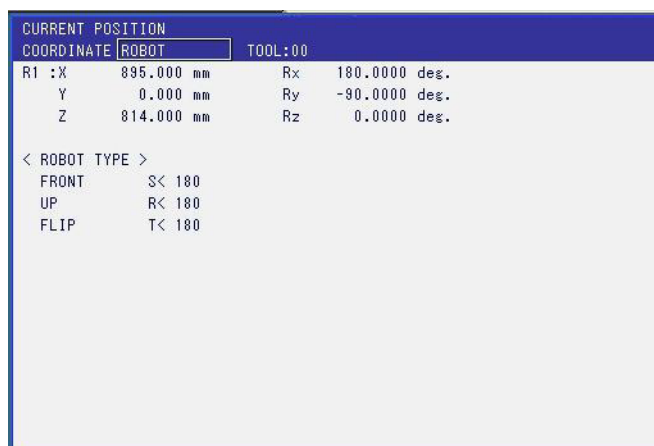

3. Set the Cartesian position indicated on the window to each POINT.

4 Details of Functional Safety Function
 4.3 Robot Range Limit Function

Setting Example of Coordinate “Base”: When setting the area shown in fig. 4-12 “Area Setting (Base)” .

Fig. 4-12: Area Setting (Base)

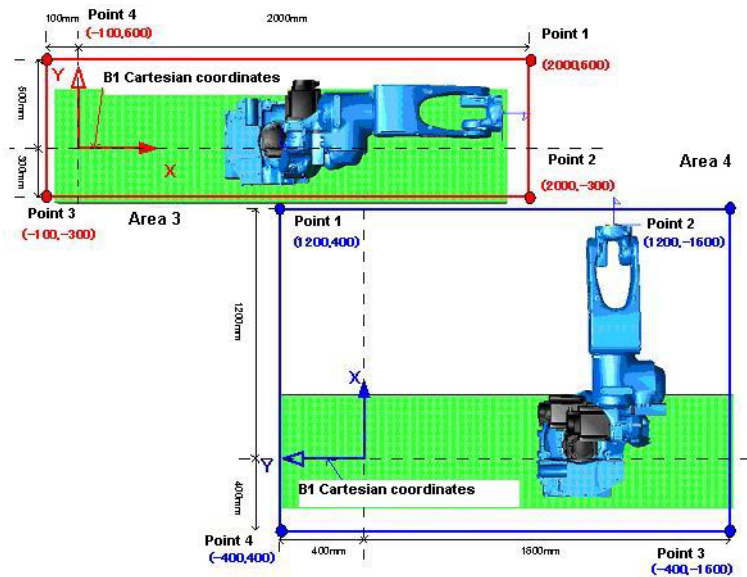

For the area 3, as shown in fig. 4-13 “Example of Condition File Setting (R1: Base)”, select R1 to CTRL GROUP and ROBOT to COORD. Also, to each POINT, set positions which are on the R1 Cartesian coordinates.

For the area 4, as shown in fig. 4-14 “Example of Condition File Setting (R2:Base)”, select R2 to CTRL GROUP and ROBOT to COORD. Also, to each POINT, set each position which are on the R2 Cartesian coordinates.

Fig. 4-13: Example of Condition File Setting (R1: Base)

| | | |
|----------------|----------|----------|
| CTRL GROUP | R1 | |
| MONITOR TARGET | INSIDE | |
| COORD | BASE | |
| SHAPE TYPE | PRISM | |
| CPU LOAD | 33 % | |
| USED POINT NUM | 4 | |
| | <X> (mm) | <Y> (mm) |
| POINT1 | 2000 | 600 |
| POINT2 | 2000 | -300 |
| POINT3 | -100 | -300 |
| POINT4 | -100 | 600 |
| <Z UPPER> (mm) | 0 | |
| <Z LOWER> (mm) | 0 | |

Fig. 4-14: Example of Condition File Setting (R2:Base)

| | | |
|----------------|----------|----------|
| CTRL GROUP | R2 | |
| MONITOR TARGET | INSIDE | |
| COORD | BASE | |
| SHAPE TYPE | PRISM | |
| CPU LOAD | 33 % | |
| USED POINT NUM | 4 | |
| | <X> (mm) | <Y> (mm) |
| POINT1 | 1200 | 400 |
| POINT2 | 1200 | -1600 |
| POINT3 | -400 | -1600 |
| POINT4 | -400 | 400 |
| <Z UPPER> (mm) | 0 | |
| <Z LOWER> (mm) | 0 | |

4 Details of Functional Safety Function

4.3 Robot Range Limit Function

When setting a position to a POINT, confirm the position following the procedures below.

1. Select {ROBOT} → {CURRENT POSITION} under the main menu.
 - The CURRENT POSITION window appears.

| CURRENT POSITION | | | |
|------------------|-------|---------|---|
| COORDINATE | PULSE | TOOL:00 | |
| R1 :S | 0 | B1 :1 | 0 |
| L | 0 | | |
| U | 0 | | |
| R | 0 | | |
| B | 0 | | |
| T | 0 | | |

2. Select {ROBOT} at {COORDINATE}.

| CURRENT POSITION | | | |
|------------------|------------|------------|---------------|
| COORDINATE | ROBOT | TOOL:00 | |
| R1 :X | 895.000 mm | Rx | 180.0000 deg. |
| Y | 0.000 mm | Ry | -90.0000 deg. |
| Z | 814.000 mm | Rz | 0.0000 deg. |
| < ROBOT TYPE > | | < ORIGIN > | |
| FRONT | S< 180 | X0 | 0.000 mm |
| UP | R< 180 | Y0 | 0.000 mm |
| FLIP | T< 180 | Z0 | 0.000 mm |

3. Add the Cartesian position indicated at <ORIGIN> to the Cartesian position indicated on the window, and then set the sum of the position to each POINT.

- 4 Details of Functional Safety Function
 4.3 Robot Range Limit Function

3. SHAPE TYPE

Specify the creating method of the monitoring area.

If either Plane (X-Y), Plane (Y-Z) or Plane (X-Z) is set to {MONITOR TARGET}, this item is invalid.

| Value | Method |
|--------|--|
| PRISM | Create lines between the created points to specify the area for the range of motion. For inside the range monitoring, up to 16 points can be specified. For outside the range monitoring, up to 4 points can be specified. |
| CUBOID | Specify two points, and then create a cuboid whose diagonal line is created by those points. This cuboid is specified as the area for the range of motion. |

4. CPU LOAD

Please refer to “6. CPU LOAD” in *chapter 4.3.2 “Robot Range Limit Function Window”*.

5. USED POINT NUM

Specify the numbers of points for creating a polygonal prism.

For the inside the range monitoring, from 3 to 16 can be input.

For the outside the range monitoring, from 3 to 4 can be input.

Ex. For triangular prism, input “3”.

For 16-prisms, input “16”.

6. POINT (X,Y)

Specify points on the X-Y plane to define a polygonal prism.

(Point 1 to 6 in *fig. 4-8 “Image of Robot Limit Range: Pattern A”*.)

The points are connected in ascending order like “POINT 1 →POINT 2→POINT3.....”. And the line of these points becomes the wall of the range of motion. Take this procedures into consideration before specifying the points.

The numbers of the points is specified by the settings of {USED POINT NUM}. The last number of the point is connected to the first one.

7. Z UPPER, Z LOWER

Specify the height of the polygonal prism. (Z Upper and Z Lower in *fig. 4-8*.)

When “0 [mm]” is set to both the Z UPPER and the Z LOWER, the height in the Z-axis direction is set to infinite (polygonal prism of infinite height).

4 Details of Functional Safety Function
 4.3 Robot Range Limit Function

■ **Pattern B**

Following is the pattern B of the indication of condition file setting window.

By scrolling down the window with the cursor, all the indication can be seen.

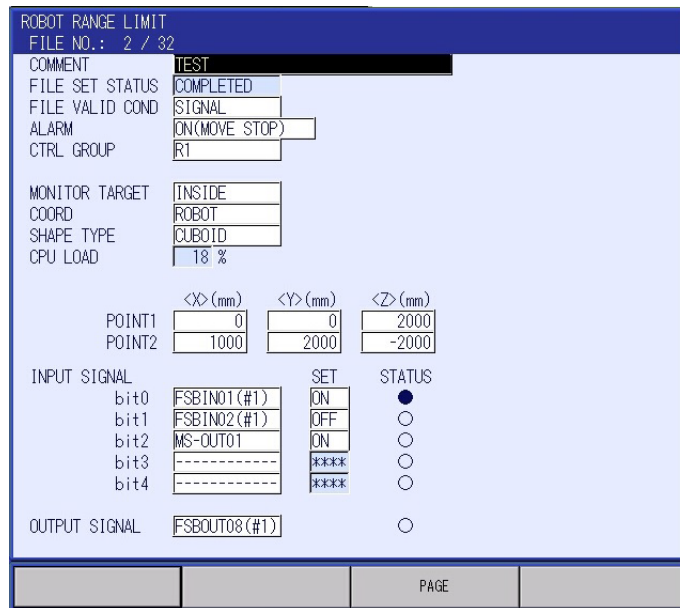

On this window, the cuboid is defined with the following two steps.

STEP 1: Define two points (point 1 and point 2) on the X -Y - Z plane to create a cuboid by regarding the connected line as its diagonal line.

STEP 2: A cuboid area is automatically created based on the specified two points.

Fig. 4-15: Image of Robot Limit Range: Pattern B

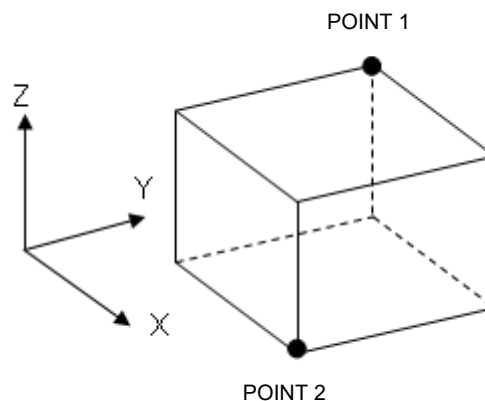

<Details of the Window>

Please refer to ■ "Pattern A" or chapter 4.8 "Common Setting Item for the Condition File" for the items not explained here in ■ "Pattern B".

8. POINT (X, Y, Z)

Specify two points on a object coordinates system, and then a cuboid is created whose diagonal line is specified by the points.

In case any two point values input in either X, Y or Z are overlapped, the setting is regarded as an error.

4 Details of Functional Safety Function
 4.3 Robot Range Limit Function

■ **Pattern C**

Following is the pattern C of the indication of condition file setting window.

By scrolling down the window with the cursor, all the indication can be seen.

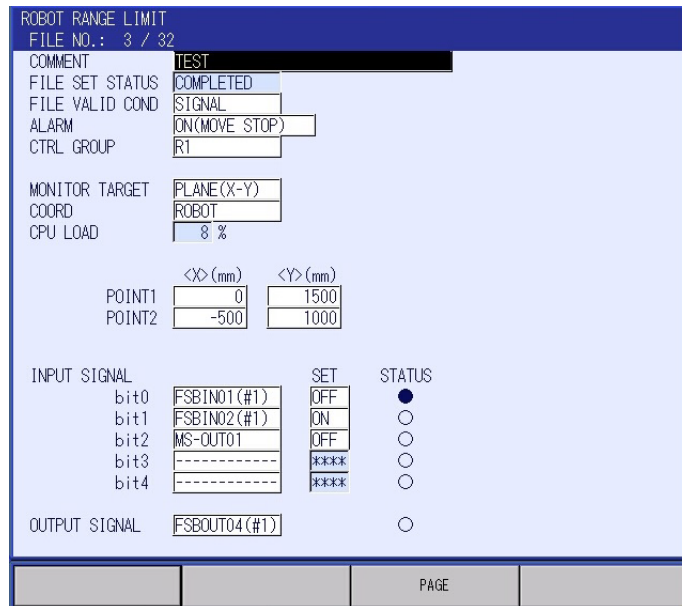

On this window, a plane is defined with the following two steps.

STEP 1: Define a straight line with two points (point 1 and point 2) on any of the selected X-Y, Y-Z or X-Z plane.

STEP 2: In a vertical direction, a plane (wall) is specified along the straight line which was defined in the STEP 1.

A plane, which is large enough to the manipulator, is specified.

Fig. 4-16: Image of Robot Limit Range: Pattern C (Area inside Dotted Line Is Non-safety Area)

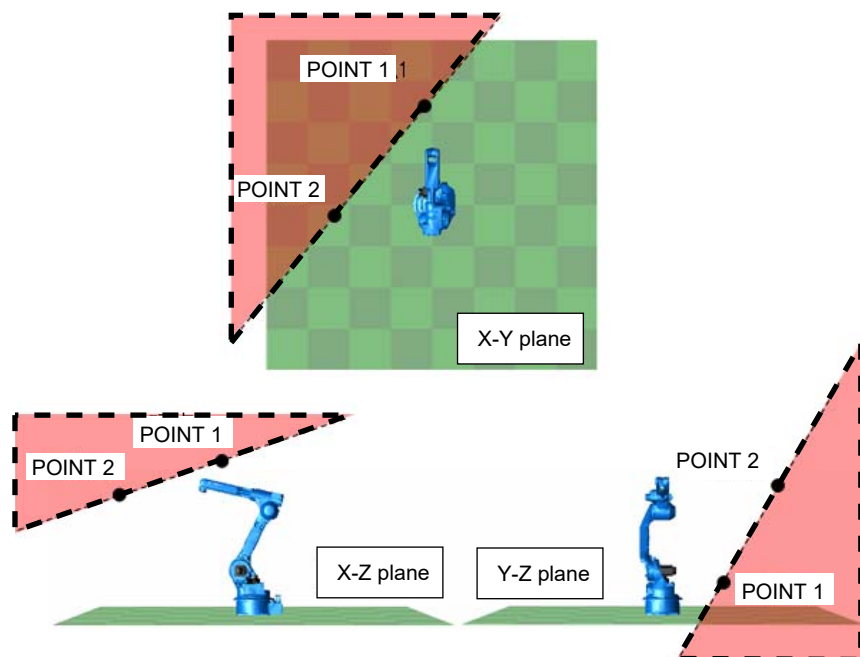

-
- 4 Details of Functional Safety Function
 - 4.3 Robot Range Limit Function
-

<Details of the Window>

Please refer to ■ “Pattern A” or chapter 4.8 “Common Setting Item for the Condition File”.

9. POINT (X,Y), (Y, Z) or (X,Z)

Specify two points to draw a straight line on a coordinate plane selected at “MONITOR TARGET”.

In case the coordinates of these two points overlapped, the setting is regarded as an error.

4 Details of Functional Safety Function

4.3 Robot Range Limit Function

4.3.4 Confirmation of the Safety Range

After the safety range is specified and {READ} is pressed, it is necessary to confirm whether the monitoring is appropriately performed inside the range.

“CONFIRMING” is indicated at “FILE SETSTATUS” on the robot range limit window. Set “VALID” to the object file by the file setting or signal condition.

Move the object manipulator or external axis to confirm whether it stops inside the specified safety range.

Fig. 4-17: CONFIRMING Window

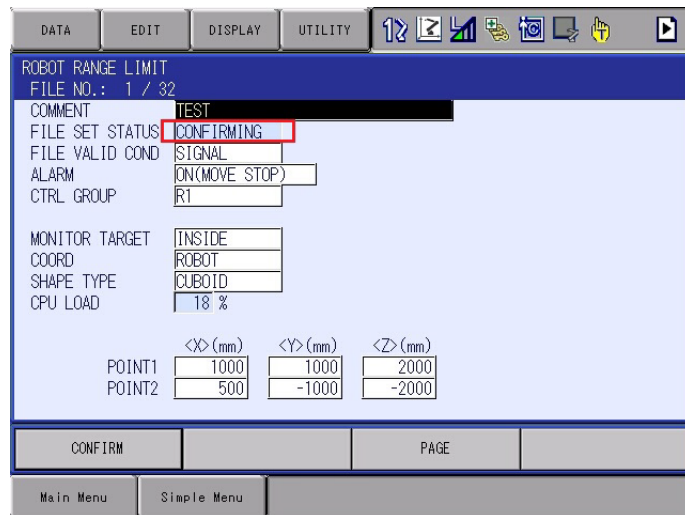

<Confirm Safety Range with Jog Operation>

With the jog operation, confirm whether the specified safety range is appropriate.

○ Inside the range monitoring

Move the manipulator inside the specified four walls and check that it stops just in front of the wall. In case the area is not a cuboid, check that it stops just in front of all walls.

Fig. 4-18: Inside the Range Monitoring

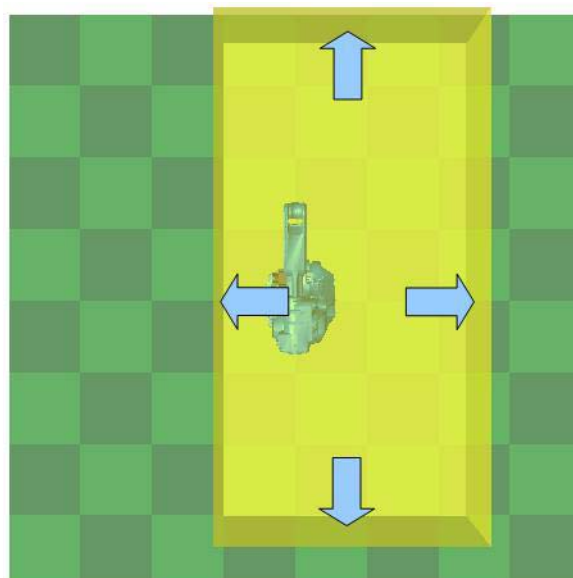

4 Details of Functional Safety Function
 4.3 Robot Range Limit Function

○ **Outside the range monitoring**

To the walls, move the manipulator toward all the direction where it can make approach and check that it stops just in front of all each wall.

Fig. 4-19: Outside the Range Monitoring

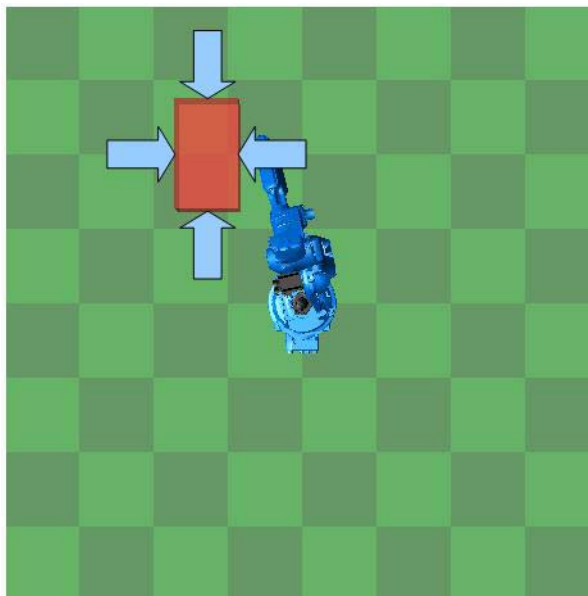

○ **Planar interference monitoring**

To the specified plane, make the manipulator approach to it. And confirm that the manipulator stops at any three points on the plane.

Fig. 4-20: Planar Interference Monitoring

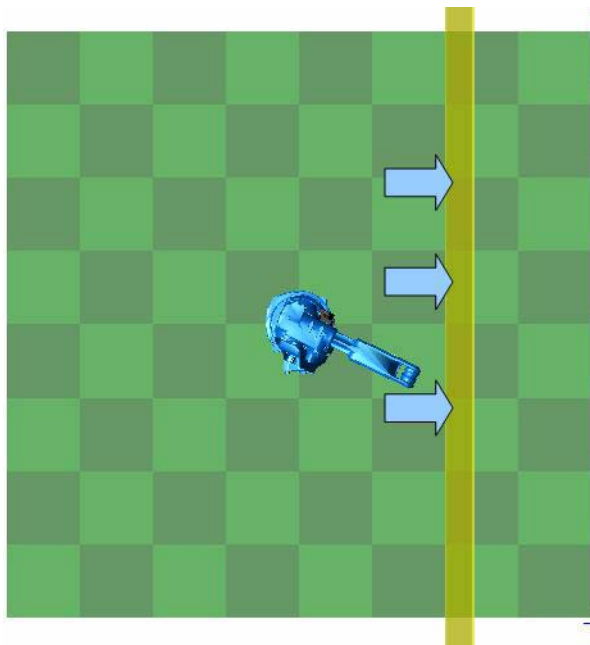

In the functional safety function, the range of motion is monitored by calculating the coasting values of the manipulator or the external axis. (Refer to *chapter 6.2 "External Axis Coasting Value Setting"*.) For this reason, the manipulator stops just short of the safety range in case it moves to the teaching point near the safety range.

| | |
|-----|---------------------------------------|
| 4 | Details of Functional Safety Function |
| 4.3 | Robot Range Limit Function |

4.3.5 Starting the Robot Range Limit

After the manipulator is confirmed that it moves to its robot range limit, press {CONFIRMED} on the window. The robot range limit function becomes valid.

Execute the play back operation of the practical movement. An alarms may occur due to inappropriate settings or teaching point setting.

In case “Alarm 4783: F-SAFE ROBOT RANGE LIMIT INTF” or “Alarm 4784: ROBOT RANGE LIMIT INTF” appeared

<Cause>

The positions of the robot and the tool are out of its safety area, or an axis range limit error is detected when the manipulator started moving. Inside the robot range limit, taking the feedback speed or the coasting value which were detected by the functional safety function, into consideration, calculation of the movement is executed so that the manipulator would not come out from the safety range. For this reason, when a manipulator moves close to the border of the range, this alarm occurs because the higher its teaching speed becomes, the more its coasting value increases.

<Countermeasure>

Check that the safety range is appropriately set.

Execute the teaching operation so that the manipulator dose not approach close to the border of the range.

Decrease the teaching speed near the border of the range.

4 Details of Functional Safety Function
4.3 Robot Range Limit Function

4.3.6 Switch the Monitoring Area

When switching the monitoring area using the safety signal input, execute the switching operation after moving the manipulator to be inside the next monitoring area and stopping it completely.

When executing inside the range monitoring at multiple ranges, set the overlapped range and execute the switching only when the manipulator is inside the overlapped area.

Fig. 4-21: When Switching the Monitoring Area

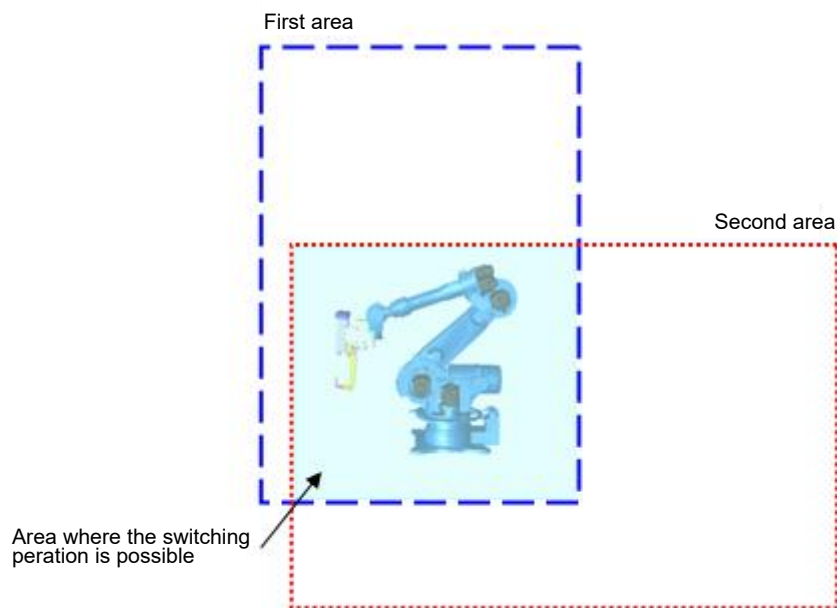

When monitoring operation is validated to multiple areas at a time, the overlapped area is regarded as the safety range.

- 4 Details of Functional Safety Function
- 4.3 Robot Range Limit Function

Inside the monitoring area + Inside the monitoring area

Fig. 4-22: Simultaneous Monitoring: Multiple Areas (Inside the Monitoring Area + Inside the Monitoring Area)

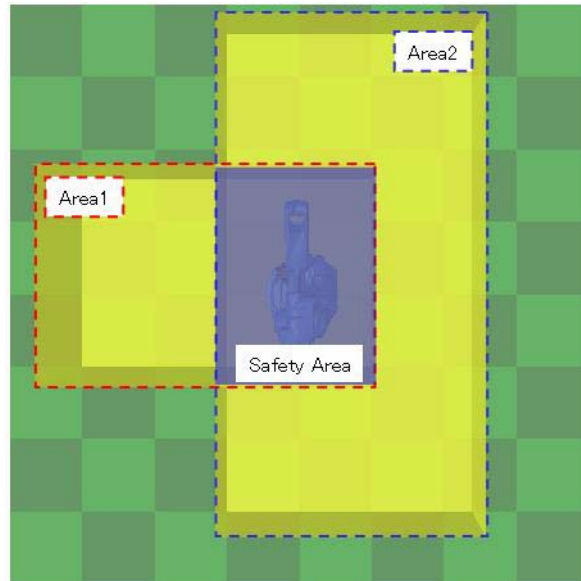

Inside the monitoring area + Outside the monitoring area

Fig. 4-23: Simultaneous Monitoring: Multiple Areas (Inside the Monitoring Area + Outside the Monitoring Area)

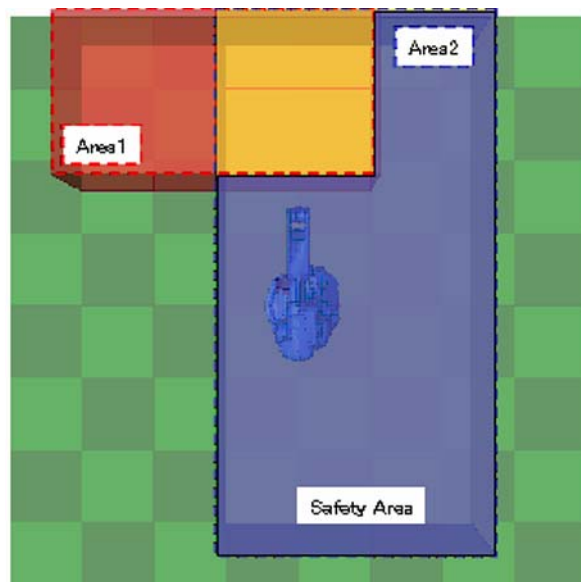

4 Details of Functional Safety Function
 4.3 Robot Range Limit Function

4.3.7 Safety Range and Manipulator Position

On the operation area monitor window, the specified safety range and the manipulator's present position can be roughly depicted on the programming pendant screen so that their position relation can be confirmed.

Follow the procedures below to open the operation area monitor window.



The data to which {WRITE} button is not yet pressed would not be reflected on the OPERATION AREA MONITOR window in case this window is opened while the robot range limit condition file is being edited.

Be sure to complete the editing operation before opening the window.



The operation area can be displayed on the 3D graphic display window. For further settings, refer to "YRC1000 GENERAL OPERATOR'S MANUAL (RE-CSO-A051) 6.19.1 3D Graphic Display Function".

1. Select {SAFETY FUNC.} under the main menu.



2. Select {OPERATION AREA MONITOR} under the sub menu.
 - The OPERATION AREA MONITOR window appears.

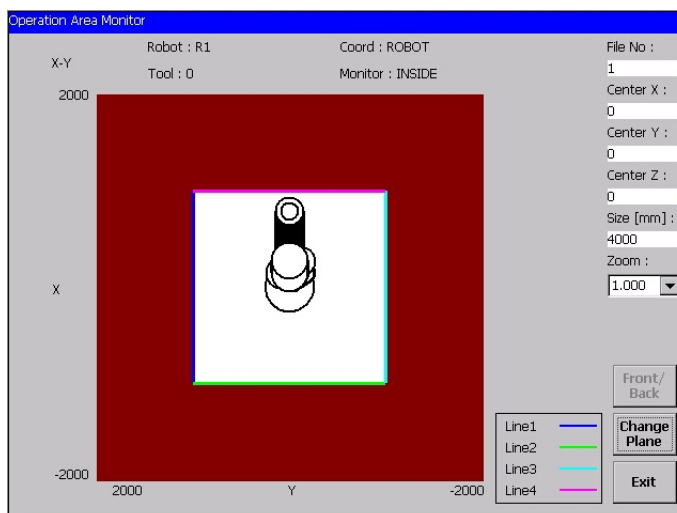

4 Details of Functional Safety Function

4.3 Robot Range Limit Function

<Details of the Window>

A. Plane X-Y, Y-Z, X-Z

The plane shown on the window now.

The manipulator and its tool are depicted in the approximate model shape specified set to the robot parameter and to the tool interference file.

When the manipulator is floor-mounted type, each figure indicates as follows;

X-Y: top view of the manipulator

Y-Z: back side view of the manipulator

X-Z: left side view of the manipulator

B. ROBOT

The number of the manipulator is indicated.

C. TOOL

The tool number specified to the manipulator shown on the window is indicated.

D. COORDINATES

The coordinates of the safety area shown on the window is indicated.

| Value | Description |
|-------|------------------|
| Base | Base coordinates |
| Tool | Tool coordinates |

E. Monitor

Monitoring method for the safety range shown on the window is indicated.

| Value | Description |
|---|---|
| Inside | Perform the inside range monitoring |
| Outside | Perform the outside range monitoring |
| Plane (X-Y) Plane (Y-Z) Plane (X-Z) | Perform the plane interference monitoring |

F. FILE No.

The number of condition file of the robot range limit function. Inputting value from 1 to 32 can switch the condition file.

G. Center X, Center Y, Center Z

Specifies the center point coordinates in the depictable range on the plane. When the plane X-Y is shown on the window, the manipulator is depicted on the plane with the center of the plane (X,Y) coordinates at its center. Unit: [mm].

H. Size

Length of one side of the depicting area is specified. Unit: [mm].

I. Zoom

Scale the indicated plane. Magnification can be selected among 0.125, 0.25, 0.5, 1, 2, 4 and 8.

When 2 is selected as its magnification, the scale of the apparent size of the plane becomes double and becomes half when 0.5 is selected.

In case the value of "CENTER" or "SIZE" is modified, the magnification at "ZOOM" returns to 1.

4 Details of Functional Safety Function

4.3 Robot Range Limit Function

J. {Front/Back} button

It is indicated only when Y-X plane indication is set. The view of the plane changes from manipulator front view to back view each time this button is pressed.

K. {Left/Right} button

It is indicated only when Y-X plane indication is set. The view of the plane changes from manipulator right side view to left side view each time this button is pressed.

L. {CHANGE PLANE} button

The plane on the window alternates every time this button is pressed.
(X-Y → Y-Z → X-Z → X-Y)

However, this button is invalid when "Plane *-*" is specified for "Monitor" because the plane view is fixed.

M. {Exit} button

Closes the operation area monitor window.

<Details of the Plane on the Window>

- Example of X-Y plane (Indication of Y-Z and X-Z are also the same when monitoring the plane.)

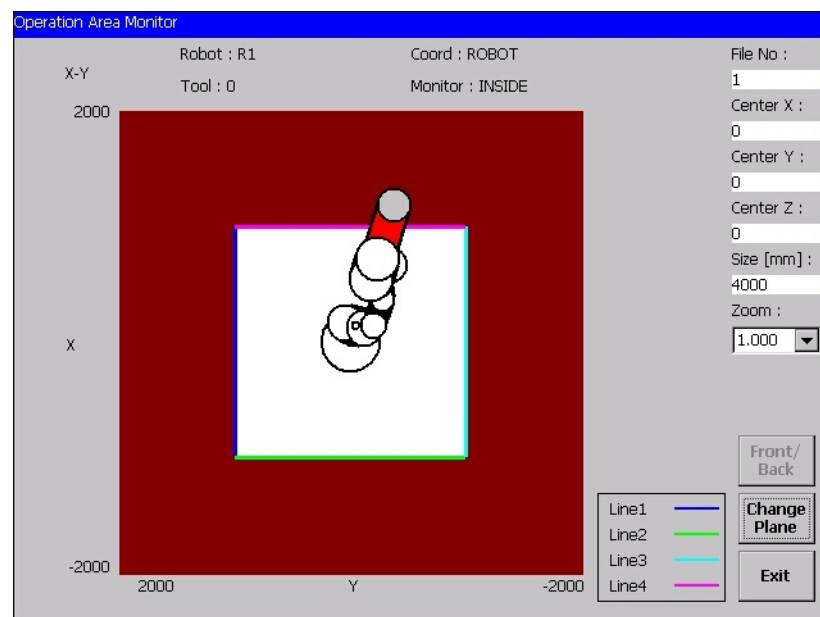

On the X-Y plane, the safety range is shown as the white area and not safety area is shown as brown area. The borders between the areas are indicated in colored lines and these lines are regarded as the wall.

The manipulator model and the tool model:

- contacting with the wall are indicated in red.
- inside the safety area are indicated in white.
- inside the not safety area are indicated in gray color.

The plane defined as Z upper or Z lower on the X-Y plane are not indicated.

4 Details of Functional Safety Function

4.3 Robot Range Limit Function

○ Example of Y-Z and X-Z planes

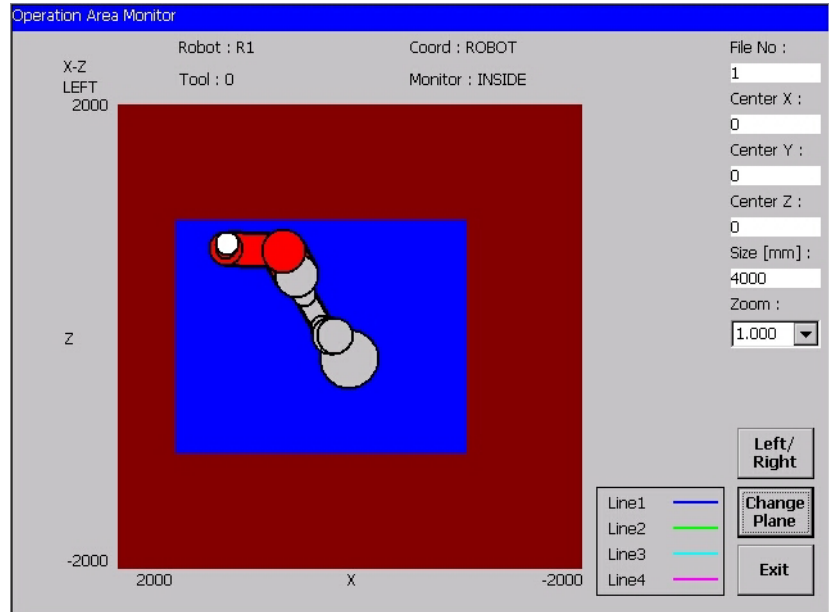

Each Y-Z and X-Z plane indicates the side of the safety area. On the Y-Z and X-Z planes, only the “wall” looked in the short from the view point is indicated.

The manipulator model and the tool model:

- seen opposite side of the “wall” are indicated in gray color.
- seen in front of the “wall” are indicated in white.
- contacting to the “wall” are indicated in red.

4 Details of Functional Safety Function
 4.3 Robot Range Limit Function

4.3.8 Proximity Warning Buzzer Setting

A warning buzzer sounds and a message “Approaching the non safety area” when the manipulator approaches a certain distance to the boundary of the non safety area. The distance object of detection can be modified on the approach warning buzzer window. The default distance is set to 50 [mm].

Also, the approaching status can be output as a user output signal. (The signal is turned ON when the manipulator is detected to be in the specified distance.) This output can be also specified on the approach warning buzzer window. This is not set in the default settings (signal is not output).

Follow the procedures below for opening the approach warning buzzer window.

1. Set the security mode to safety mode and then, select {SAFETY FUNC.} under the main menu.

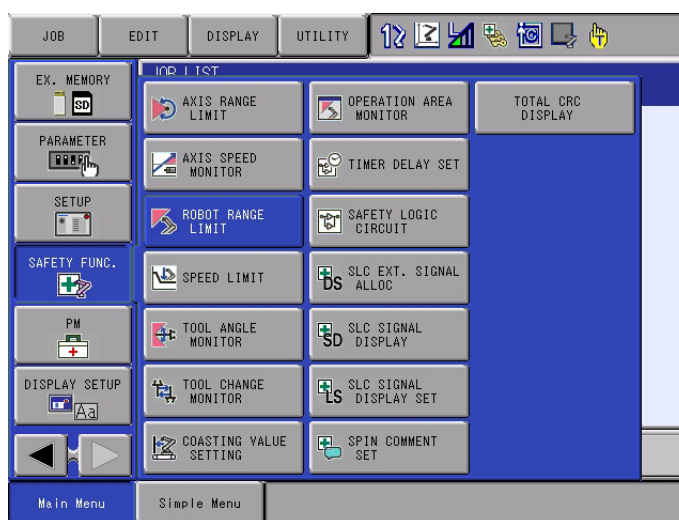

2. Select {ROBOT RANGE LIMIT} in the sub menu.

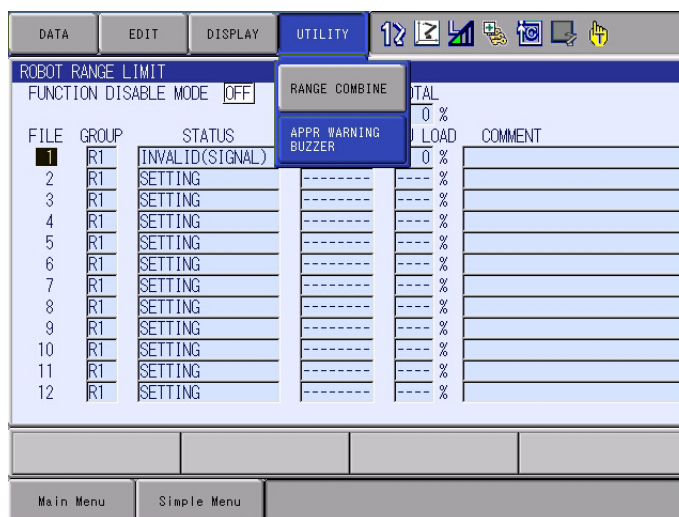

4 Details of Functional Safety Function
4.3 Robot Range Limit Function

3. Select {UTILITY} → {APPR WARNING BUZZER}.

– The APPROACH WARNING BUZZAR window appears.

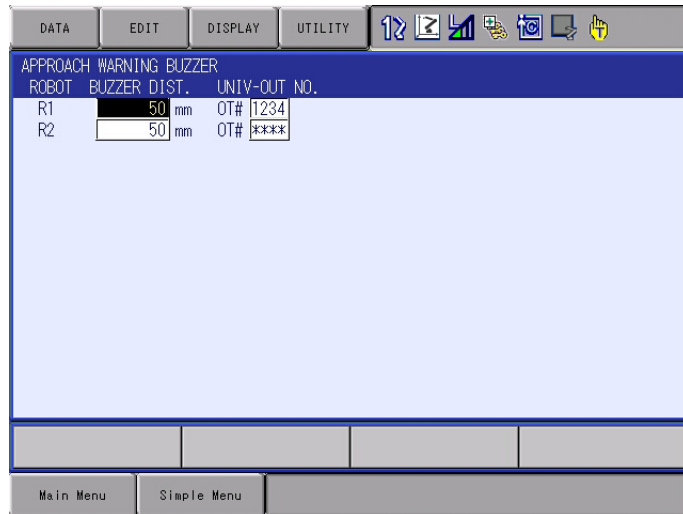

<Details of the Window>

1. BUZZER DIST.

Specify a manipulator approaching distance to sound a buzzer.

Unit: [mm]

2. UNIV-OUT NO.

Specify an user output signal number for outputting the status of detecting the approach. When "0" is set, "****" is displayed and no signal is output.

4 Details of Functional Safety Function
 4.3 Robot Range Limit Function

4.3.9 Combining Function of Multiple Monitoring Areas

This function creates a new monitoring areas by combining two already-specified monitoring areas.

Follow the procedures below for this operation.

1. Set the security mode to safety mode, and then select {SAFETY FUNC.} under the main menu.

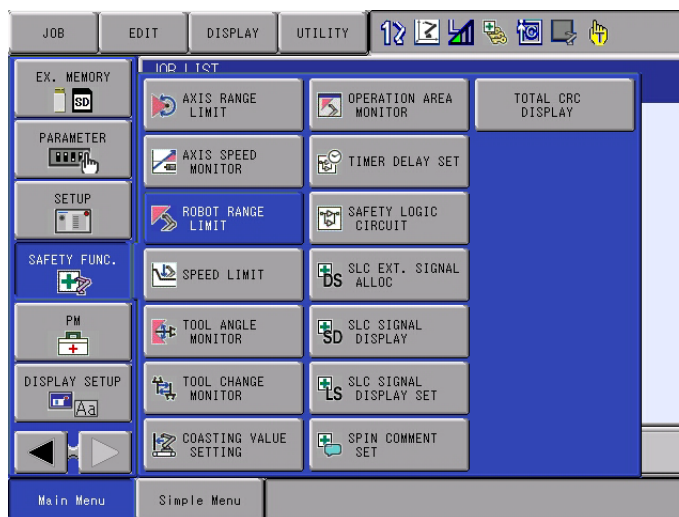

2. Select {ROBOT RANGE LIMIT} in the sub menu.

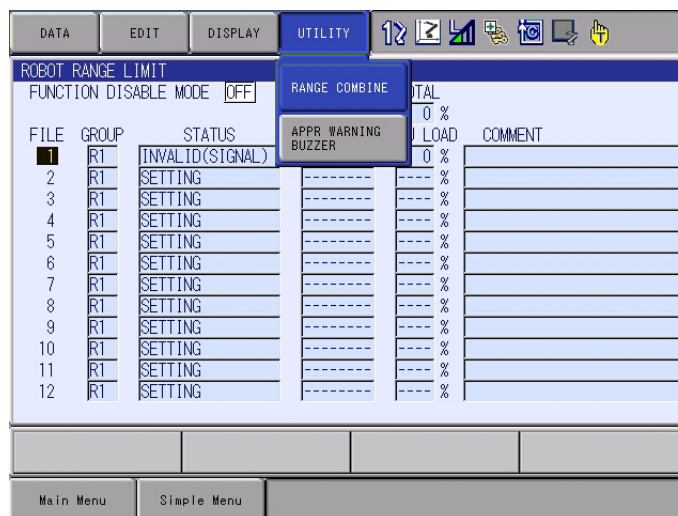

4 Details of Functional Safety Function
 4.3 Robot Range Limit Function

3. Select {UTILITY} → {RANGE COMBINATION}.

– The RANGE COMBINATION window appears.

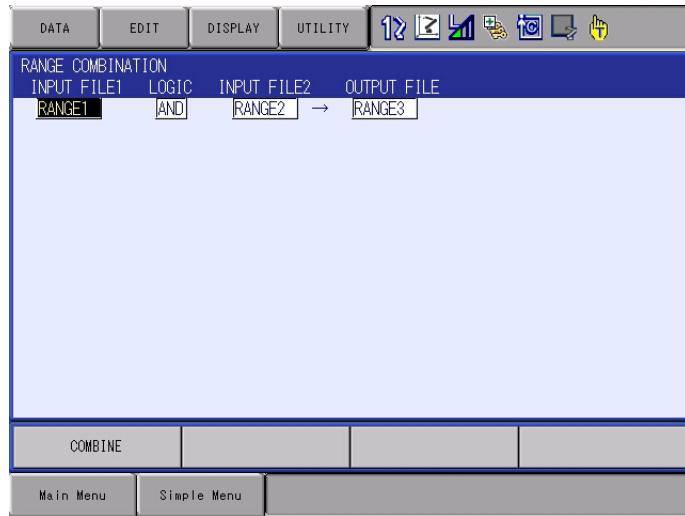

<Details of the Window>

1. INPUT FILE1, INPUT FILE2

Specify the file number of the range to combine.

| Value | Description |
|---------------|--|
| Range 1 to 32 | Select the number of the range to be input from 1 to 32. |

2. LOGIC

Logic for combining the areas.

| Value | Description |
|-------|---|
| AND | Combine the selected two areas with the logic of "AND". |
| OR | Combine the selected two areas with the logic of "OR". |

○ Combination with "AND"

The overlapped area by the combination of two safety areas is created as a new monitoring area.

Fig. 4-24: Image: Combined Area with "AND"

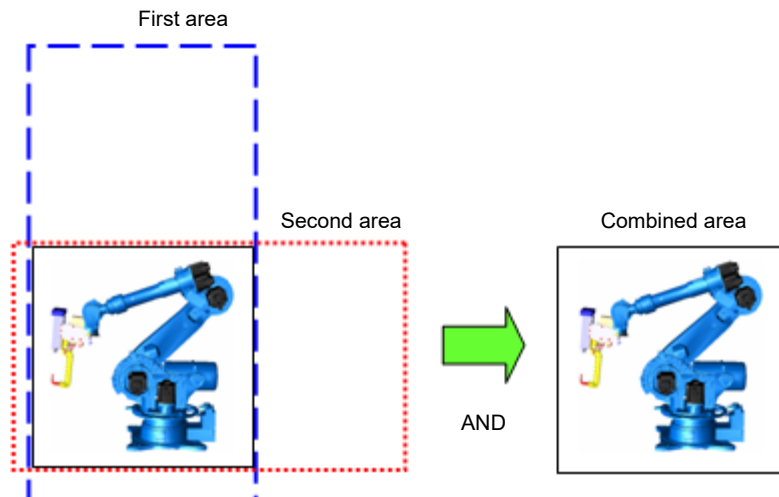

4 Details of Functional Safety Function
 4.3 Robot Range Limit Function

○ **Combination with “OR”**

The whole area consists of two safety areas is created as a new monitoring area.

Fig. 4-25: Image: Combined Area with “OR”

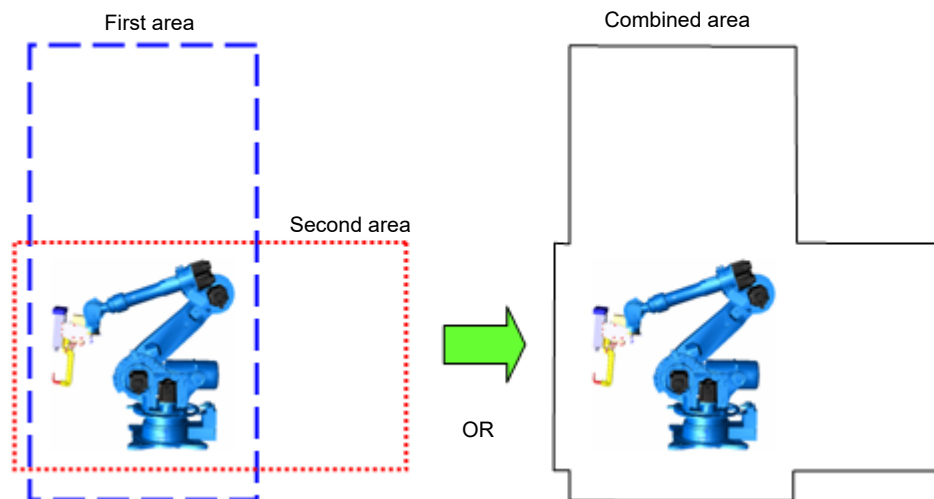

3. OUTPUT FILE

Specify the file number of the combined area.

For the file number to be output, choose a file to which the monitoring operation is set invalid because the file number is overwritten.

In case choosing a file to which the monitoring operation is set valid, an error occurs.

| Value | Description |
|---------------|---|
| Range 1 to 32 | Select the number of the range to be output from 1 to 32. |

<Combining restrictions>

Combination of the areas are not executed when:

- The two areas are not connected
- Inside the range monitoring and the outside the range monitoring are selected.
- The robot coordinates and the base coordinates are selected.
- The height of each area is different and “OR” is selected as their logic.
- Same file number is specified at {INPUT FILE} and {OUTPUT FILE}
- The shape of the range specified to the input file is not convex.

4.3.10 Extend Function of Robot Interference Model

NOTE This function is optional and can be used in system software version YAS4.74.00A(□)-00 or later.

This function can extend the settings for the robot interference model by a maximum of three models (set consisting of a sphere and cylinder). The offset distance at the center point of the sphere and the radius of the sphere can be set to the optional reference axis. The cylinder can be set automatically to connect the added sphere and the sphere set to the reference axis. The cylinder radius can be set automatically to fit the smaller radius of the sphere or the reference axis.

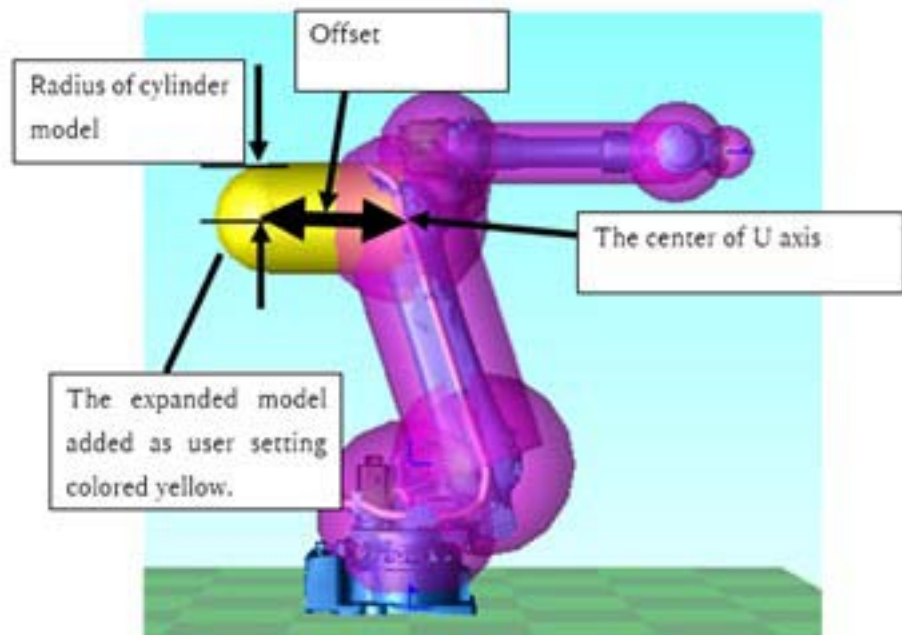

Follow the procedures below for this operation.

1. Set the security mode to safety mode, and then select {ROBOT} under the main menu.

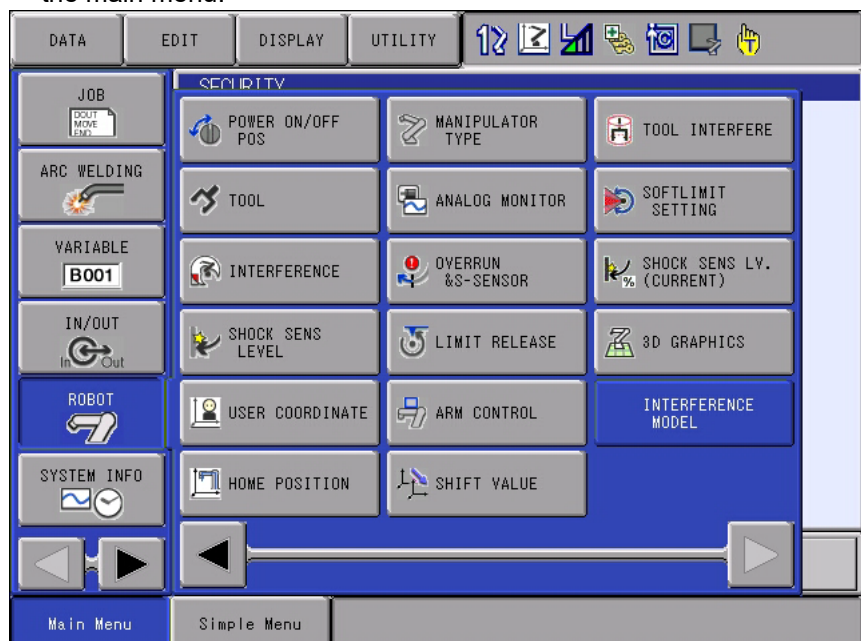

- 4 Details of Functional Safety Function
- 4.3 Robot Range Limit Function

- 2. Select {INTERFERENCE MODEL} in the sub menu.

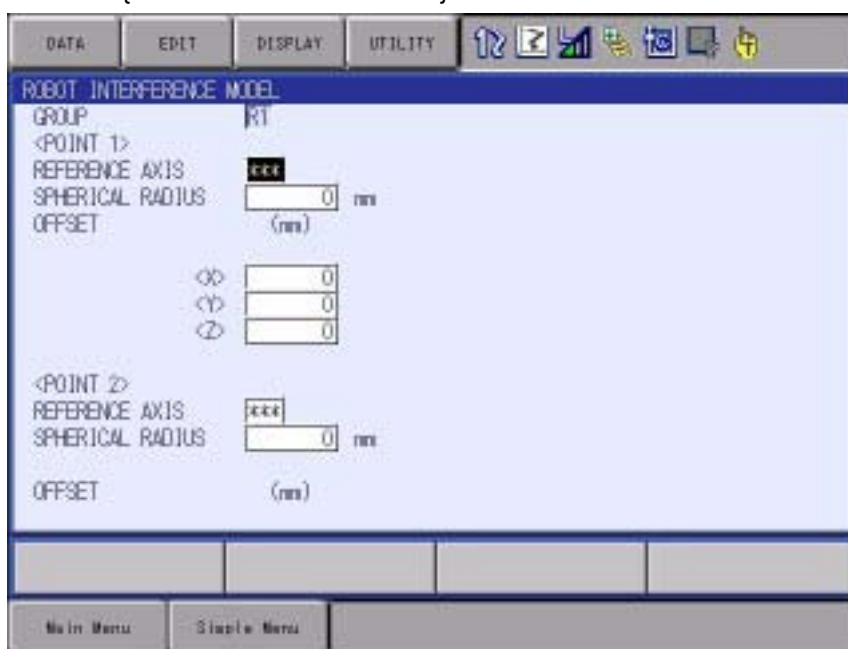

<Details of the Window>

1. GROUP

Select a robot which you desire to add expanded model.

2. REFERENCE AXIS

Specify an axis where expanded robot model will be defined based on.

3. SPHERICAL RADIUS

Specify the radius of sphere and cylinder added.

4. OFFSET<X>

Specify the X distance from based the axis coordinate system toward expanded sphere model.

*This item is not the X distance in the robot coordinates. It is the X distance in the calculated coordinate system of the reference axis.

5. OFFSET<Y>

Specify the Y distance from based the axis coordinate system toward expanded sphere model.

*This item is not the Y distance in the robot coordinates. It is the Y distance in the calculated coordinate system of the reference axis.

6. OFFSET<Z>

Specify the Z distance from based the axis coordinate system toward expanded sphere model.

*This item is not the Z distance in the robot coordinates. It is the Z distance in the calculated coordinate system of the reference axis.

7. PAGE

The PAGE button will appear when the system has robots greater than two. The button switches the content of display to other robot group.

4.4 Speed Limit Function

4.4.1 Outline

Speed limit function is a function which sets the upper limit of the robot group control point (TCP: Tool Center Point) speed and flange center point (FCP) speed, and then monitors whether the speed at each point does not exceed the already-fixed speed using a software.

When applying the function to a station group, the upper limit is set for the motor rotating speed.

Fig. 4-26: TCP (Tool Center Point) and FCP (Flange Center Point)

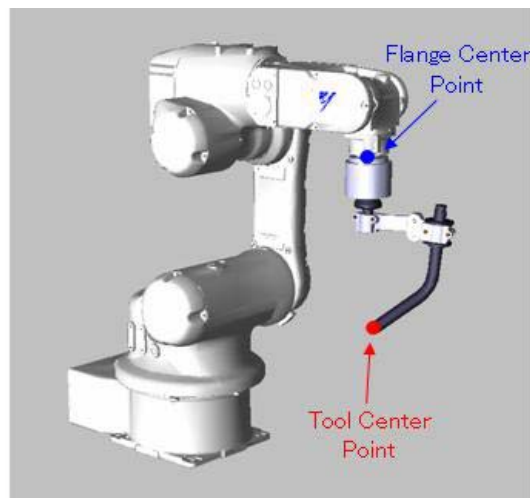

When "0" is set to speed limit, it is called stop position monitoring. The manipulator or the station group can be monitored by stop position monitoring.

For the manipulator group, the stop position monitoring is performed to TCP or FCP to confirm each point does not move.

For the station group, the stop position monitoring is performed to each axis position to confirm each axis does not move.

When the function file of the speed limit function is validated and in case the taught speed is faster than the limited speed, the speed is decreased to the limited speed, and the monitoring starts.

The time for decreasing the speed varies depending on the manipulator type or teaching conditions. For this reason, in the functional safety function, the period of time from validating the condition file to complete decreasing is regarded as the detection delay time and this can be set to the condition file.

4 Details of Functional Safety Function

4.4 Speed Limit Function

Fig. 4-27: Outline of Speed Limit Function

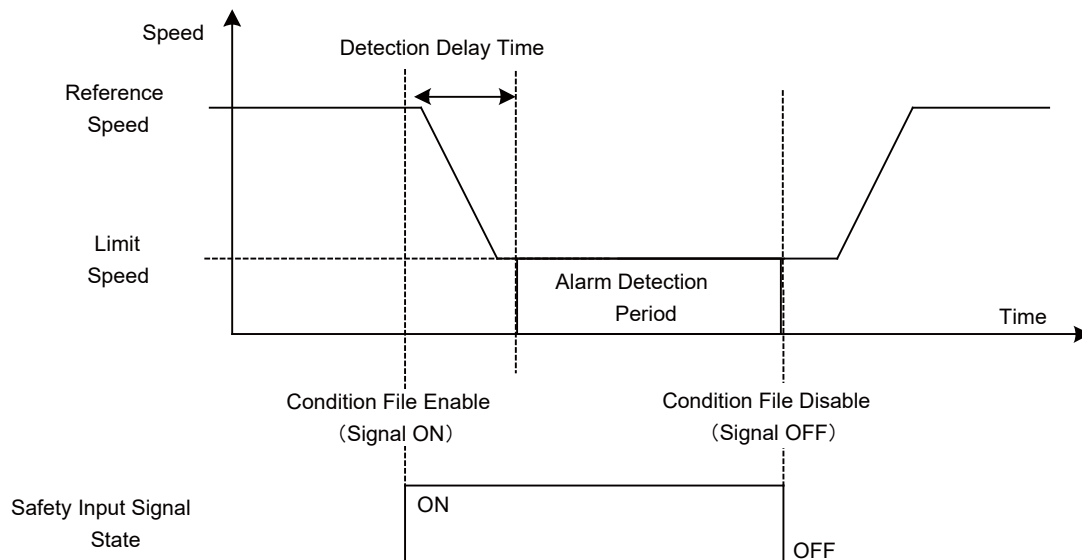

Thirty two files are prepared to this function and all axes motion range of any one control group is set to a file. When a control group is set to several files, the control group can be monitored by switching conditions.

In case an error is detected, the power supply to the motor is stopped using the machine safety. And the error is notified using an alarm.

Along with the above mentioned monitoring, when it is in the teaching mode, the speed is always monitored to be 250 mm/sec as the teach mode safety speed.

Follow the procedures below when starting the speed limit function.

1. Set the tool file.
(Before using this function, execute tool file setting by referring to *chapter 6.3 "Tool File Setting"* .)
2. Set the speed limit condition file.
3. Start the speed limit function.

4 Details of Functional Safety Function
 4.4 Speed Limit Function

4.4.2 Speed Limit Function Window

Followings are the setting procedures for the axis range limit function.

1. Set the security mode to the safety mode, and then select {SAFETY FUNC.} under the main menu.

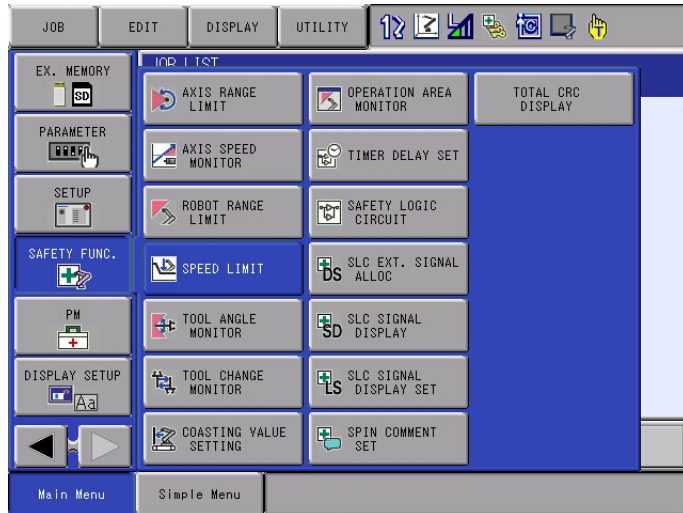

2. Select {SPEED LIMIT} in the sub menu.
 - The list of the speed limit status appears.

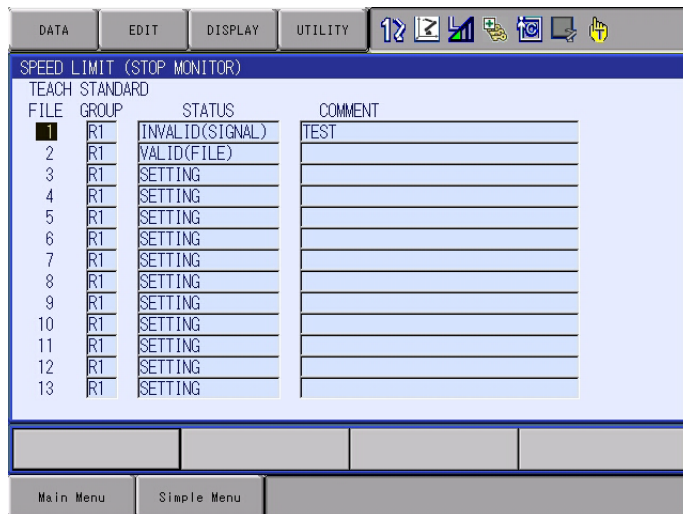

On the status list window, the 32 configuration files for the axis range limit function are listed so that their status can be confirmed. By scrolling down the window, all the list can be seen.

-
- 4 Details of Functional Safety Function
 - 4.4 Speed Limit Function
-

<Details of the Window>

1. TEACH STANDARD

Move the cursor to this item and press [SELECT] to display the list of speed limit for the teach mode.

2. FILE

Displays the file number for each condition.

Move the cursor to a desired file number and press [SELECT] to display the settings window of the condition file of the file number.

3. GROUP

Displays the object group for the monitoring for the present condition file.

4. STATUS

Displays the present monitoring status of the condition file.

| Value | Description |
|------------------|--|
| SETTING | The condition file is in the initial status or in the data setting status. Not monitoring yet. |
| VALID (FILE) | Data setting is completed and monitoring status of the file is in valid status. |
| INVALID (FILE) | Data setting is completed and monitoring status of the file is in invalid status. |
| VALID (SIGNAL) | Data setting is completed and monitoring status of the file is in valid status by the establishment of the safety signal condition. |
| INVALID (SIGNAL) | Data setting is completed and monitoring status of the file is in invalid status by the disestablishment of the safety signal condition. |

5. COMMENT

Displays the input comment.

4 Details of Functional Safety Function
 4.4 Speed Limit Function

4.4.3 Speed Limit Function Condition File Setting Window

1. On the status list window, select a file number with the cursor, and then press [SELECT].

– The individual setting window for the speed limit function opens.

The display on the window varies which group is to be monitored; robot group or station group.

<When the robot group is monitored>



<When the station group is monitored>

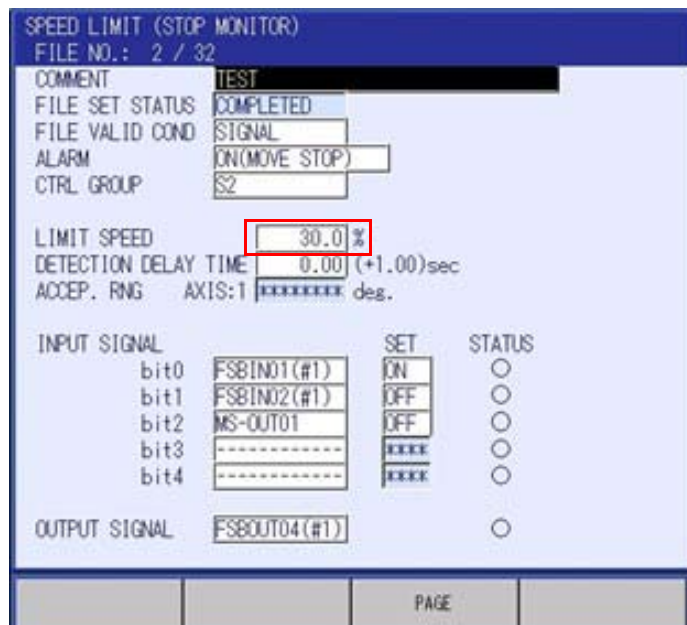

By scrolling down the window with the cursor, all the indication can be seen.

<Details of the Window>

In this section, only the items to the axis range limit are explained. For the items not mentioned here, please refer to *chapter 4.8 "Common Setting Item for the Condition File"*.

1. LIMIT SPEED

Specify the speed limit to the motion speed in the object group.

When the robot group is monitored, the limit speed is specified with the unit [mm/sec].

When the station group is monitored, the limit speed is specified with the unit [%]. The unit [%] is same as the set value of target axis single operation with MOVJ=xx%. For example, the target axis stops when 0% is specified and moves with maximum speed when 100% is specified.

During speed limit, all axis speeds in the group is controlled under specified limited value [%]. As for station group which has several axes, the fastest motion speed ([%]) axis in the group are limited in specified speed. Other axes speed in the same group are also limited in same ratio.

The speed limit function limits the rotation speed of the motor axis in the station group.

The speed 100% is equivalent to the maximum rotation speed of a motor (unit: rpm) specified in the maintenance mode. (For the maximum rotation speed of a motor, refer to "YRC1000 INSTRUCTIONS (RE-CTO-A221) 12.3 Addition of Base and Station Axes".)

The motion speed of the load axis is calculated with the rotation speed of the motor and reduction ratio in the mechanisms as follows.

$$\text{Rotation speed of the motor axis} \times \text{Reduction ratio} \\ = \text{Rotation speed of the load axis}$$

Also, the load shape should be considered for the motion speed. In the case of the disc-like load applied around the load axis, the motion speed becomes faster as the load is applied in the outer periphery.



When the station group has two or more motor axes, the load may be moved by several motors. In this case, the load motion speed is determined by the composite speed of the motors. This speed can be faster than the single motor motion speed.

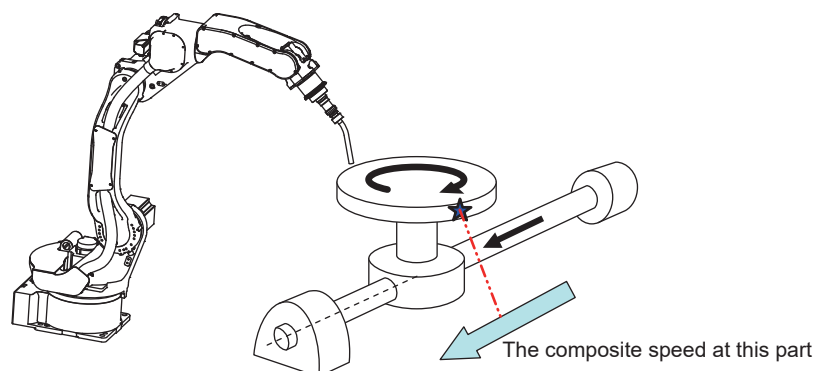

Before using this function, set the limit speed so that the target part in the load side becomes in the acceptable speed range and perform enough risk assessment.



WARNING

In case the customer performs the setting for the station group, refer to “YRC1000 INSTRUCTIONS (RE-CTO-A221) 12.3.2 Station Axis Setting” and set the axis mechanical specification (the motor type, the maximum rotation speed, etc.) properly.

If using the manipulator in improper setting, the safety function does not operate normally and a serious accident may occur.



When limiting speed with low speed (0.1~5[mm/sec] or 0.1~5[%]), even during speed limit, F-SAFETY SPEED LIMIT ERROR alarms may occur due to tiny motions such as turning ON of the servo.

When the situation requires, take measures, for example, review limit speed or limit section, or use stop monitoring.

2. DETECTION DELAY TIME

Specify a time frame from validating the condition file to start the alarm detection.

Even if the set value is “0”, 1 [sec] is detected as the detection delay time since the default value is set to this item.

For this reason, when a value is specified to this item, 1 [sec] + the specified value is regarded as the detection delay time.

3. ACCEPTABLE RANGE

This item can be specified when “0” is set to “SPEED LIMIT”. Also, this item is used when the stop position monitoring is performed. Although the stop position monitoring monitors the difference between the stop position monitoring start position and the present position, to avoid any alarms from occurring due to tiny motions such as turning ON of the servo during the monitoring, “ACCEPTABLE RANGE” is specified.

An alarm occurs when the axis moves to exceed the position where the acceptable range is added to the stop position monitoring start position. When the robot group is monitored, it is measured in [mm].

and when the station group is monitored and the axis is a rotating axis, it is measured in [deg], and is [mm] when the axis is a linear-motion axis.

4 Details of Functional Safety Function

4.4 Speed Limit Function

4.4.4 Starting the Speed Limit

Specify the speed limit function and press {WRITE} button, the speed limit function becomes valid.

4.4.5 Speed Limit in Teach Mode

While the teach mode is selected, to strictly observe the safety speed, the speed monitoring of 250 [mm/sec] is performed in the functional safety function. Unlike other speed limit function, this monitoring function cannot be set invalid by the condition file setting.

However, only when the full speed test is input by the external signal and when the manual brake is released, this monitoring function can be set invalid and the speed can be increased faster than 250 [mm/sec] even during the teach mode.

For the full speed test, refer to “YRC1000 INSTRUCTIONS (RE-CTO-A221) 8.26 Safety Logic Circuit”.

For releasing the manual brake function, refer to “YRC1000 OPTIONS INSTRUCTINS FOR MANUAL BRAKE RELEASE FUNCTION (HW1483370)”.



When using the full speed test or manual brake release functions, possible risks attributed to the speed limit release should be sufficiently considered (risk assessment) before operating the manipulator.

The condition file setting window for the speed limit function in the teaching mode opens by the following procedures.

1. Set the security mode to safety mode, and then select {SAFETY FUNC.} under the main menu.

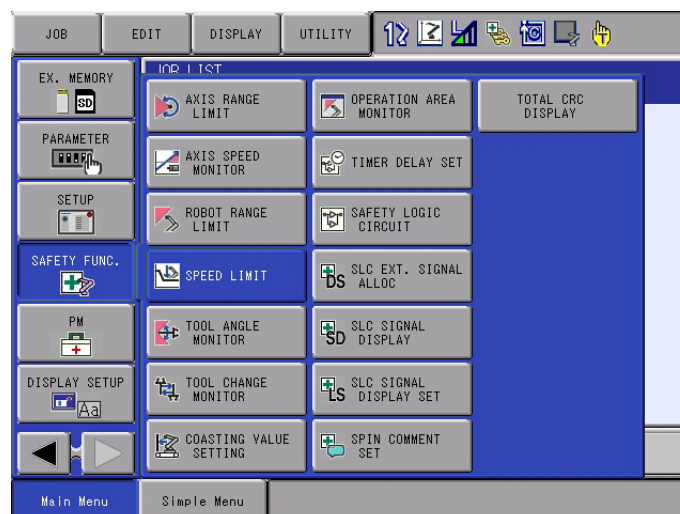

4 Details of Functional Safety Function

4.4 Speed Limit Function

2. Select {SPEED LIMIT} in the sub menu.

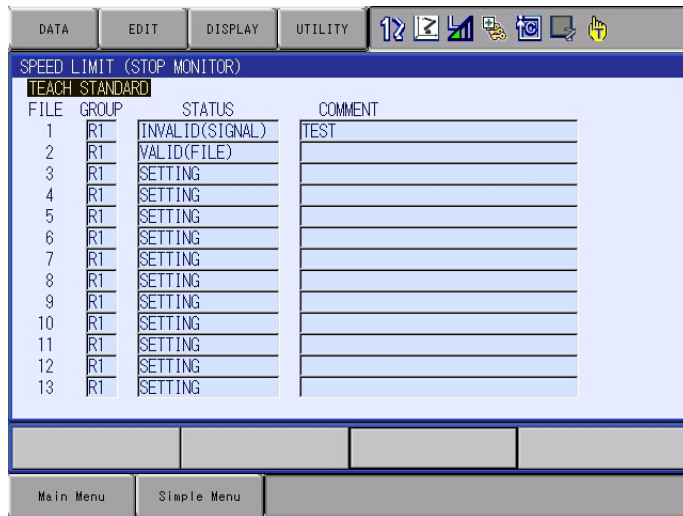

3. Select {TEACH STANDARD}.

– A list of condition file of the teach mode speed limit appears.

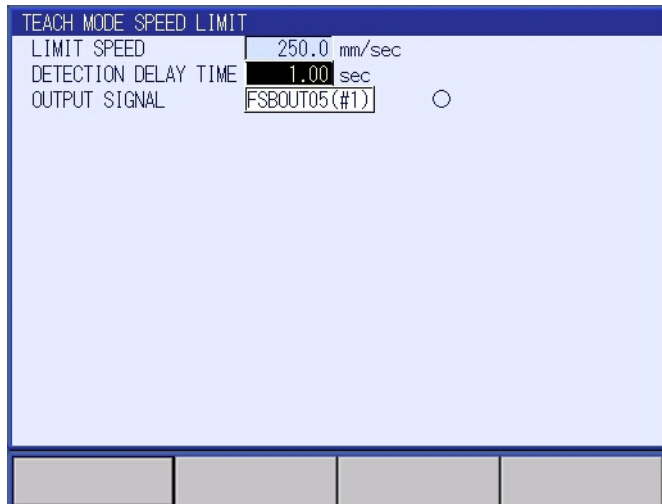

<Details of the Window>

1. LIMIT SPEED

It is fixed to 250 [mm/sec] and not modified.

2. DETECTION DELAY TIME

Specify a time frame from validating the condition file to start the alarm detection. It is set as the time for decreasing the speed slower than 250 [mm/sec] when the full speed test function is released. Even if the set value is "0", 1 [sec] is detected as the detection delay time since the default value is set to this item. For this reason, when a value is specified to this item, 1 [sec] + the specified value is regarded as the detection delay time.

| | |
|-----|---------------------------------------|
| 4 | Details of Functional Safety Function |
| 4.5 | Tool Angle Monitor Function |

4.5 Tool Angle Monitor Function

4.5.1 Outline

The tool angle monitor function is a function that monitors the angle of the tool by specifying the standard value of manipulator tool tilting angle and the limit of the tool angle, and then, using the software, monitors whether the standard value-centered tool angle does not exceed the specified limit angle. In case the tool file is not specified, it monitors the tilting angle of the flange.

To the object manipulator group, the tool tilting angle which is regarded as the reference for the monitoring is defined as "REF. ANGLE". At this time the tool posture is calculated on the basis of the base coordinates as its standard. While the condition file is validated, this function monitors whether the "REF. ANGLE"-centered angle of the tool does not exceed the specified limit of the tool angle.

In case an error is detected, the power supply to the motor is stopped using the machine safety.

Thirty two files are prepared to this function and all axes motion range of any one control group is set to a file. When a control group is set to several files, the control group can be monitored by switching conditions.

Fig. 4-28: TOOL ANGLE MONITOR (EX: Laser Welding Application)

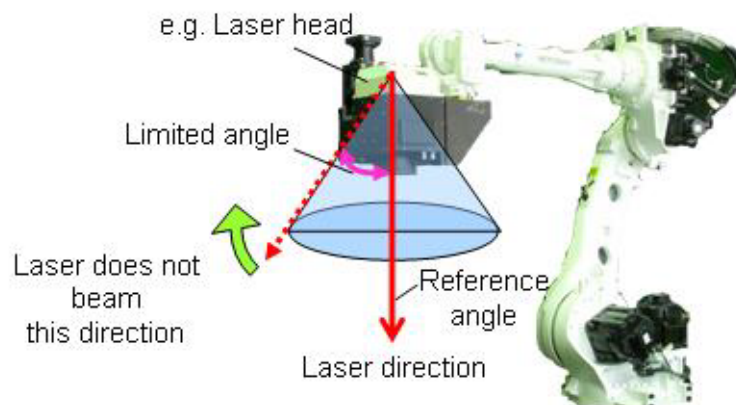

Follow the procedures below when starting the tool angle monitor function.

1. Set the tool file.
(Before using this function, execute tool file setting by referring to *chapter 6.3 "Tool File Setting"* .)
2. Set values to {REF. ANGLE} and {LIMIT ANGLE}.
3. Confirm the safety range.
4. Start the tool angle monitor function.

4 Details of Functional Safety Function
 4.5 Tool Angle Monitor Function

4.5.2 Tool Angle Monitor Function Window

Followings are the setting procedures for the tool angle monitor function.

1. Set the security mode to the safety mode, and then select {SAFETY FUNC.} under the main menu.

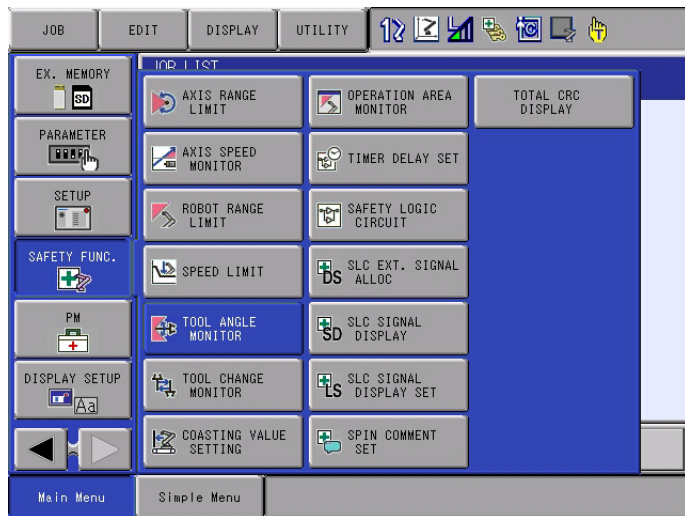

2. Select {TOOL ANGLE MONITOR} under the sub menu.
 - The list of the tool angle monitor status appears.



On the status list window, the 32 configuration files for the axis range limit function are arranged so that their status can be confirmed. By scrolling down the window, all the list can be seen.

- 4 Details of Functional Safety Function
- 4.5 Tool Angle Monitor Function

<Details of the Window>

1. FUNCTION DISABLE MODE

Specify ON/OFF of the tool angle monitor function. When ON is set to this item, this function can be temporarily invalidated.

| Value | Description |
|-------|--|
| OFF | The tool angle monitor function is valid. |
| ON | The tool angle monitor function is invalid. At the same time, playback, test-run, forward/backward operations are prohibited. |

For the details, refer to *chapter 6.1 "Function Disable Mode Setting"*.

2. FILE

The number of the condition file is displayed.

Move the cursor to any number and press [SELECT]. The individual setting window for the selected condition file appears.

3. GROUP

The control group to be monitored specified by the condition file

4. STATUS

Monitoring status of the present condition file

| Value | Description |
|------------------|--|
| SETTING | The condition file is in the initial status or in the data setting status. Not monitoring yet. |
| CONFIRMING | Confirming the area after the data is set. The status of the monitoring operation depends on the valid condition of the condition file. |
| VALID (FILE) | Data setting is completed and monitoring status of the file is in valid status. |
| INVALID (FILE) | Data setting is completed and monitoring status of the file is in invalid status. |
| VALID (SIGNAL) | Data setting is completed and monitoring status of the file is in valid status by the establishment of the safety input signal condition. |
| INVALID (SIGNAL) | Data setting is completed and monitoring status of the file is in invalid status by the disestablishment of the safety input signal condition. |

5. COMMENT

The input comment is displayed.

4 Details of Functional Safety Function

4.5 Tool Angle Monitor Function

4.5.3 Tool Angle Monitor Condition File Setting

- On the status list window, select a file number with the cursor, and then press [SELECT].
 - A setting window for the selected condition file of the axis range monitor function appears.

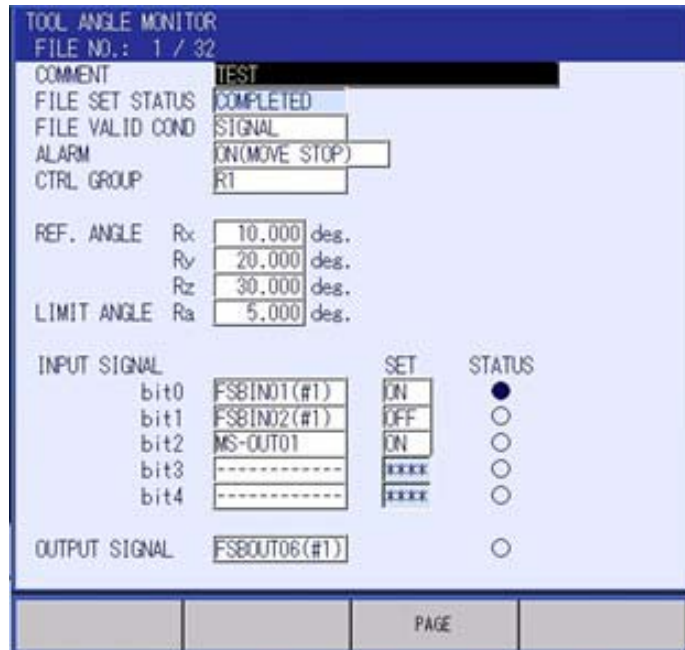

By scrolling down the window with the cursor, all the items can be seen.

<Details of the Window>

In this section, only the items inherent to the tool angle monitor function are explained. For the items not mentioned here, please refer to *chapter 4.8 "Common Setting Item for the Condition File"*.

1. REF. ANGLE

Input a tool angle as a reference value for the tool angle monitor function.

Follow the procedures below to confirm the present tool tilting angle.

- Select {ROBOT} under the main menu.

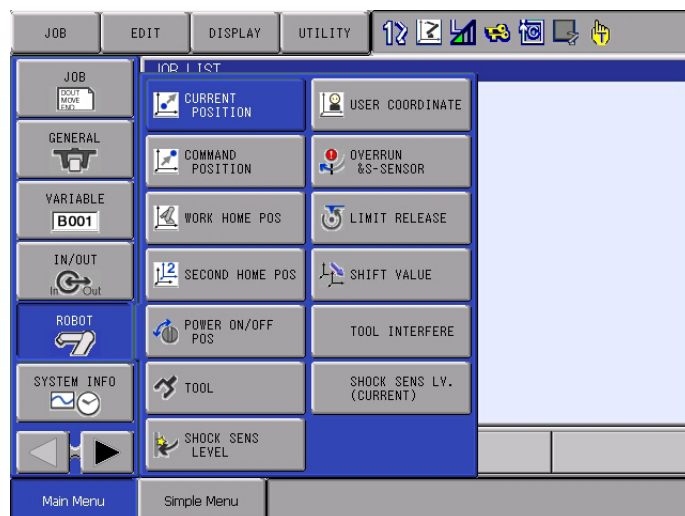

4 Details of Functional Safety Function

4.5 Tool Angle Monitor Function

2. Select {CURRENT POSITION} under the sub menu.

– The CURRENT POSITION window appears.

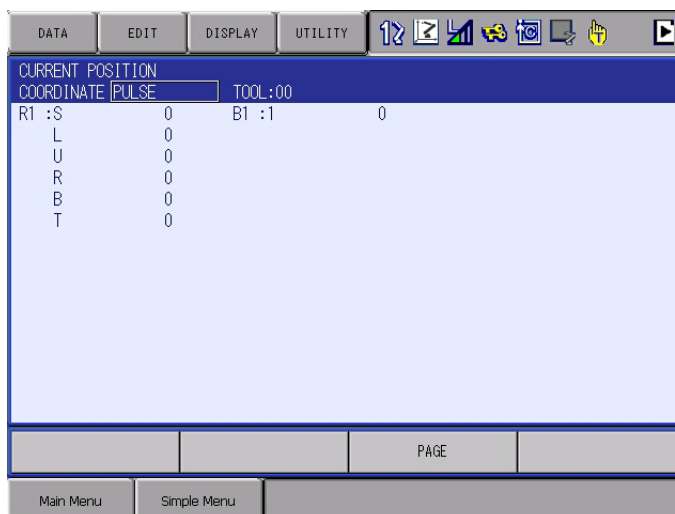

3. Select "BASE" in the selection box under {COORDINATE}.

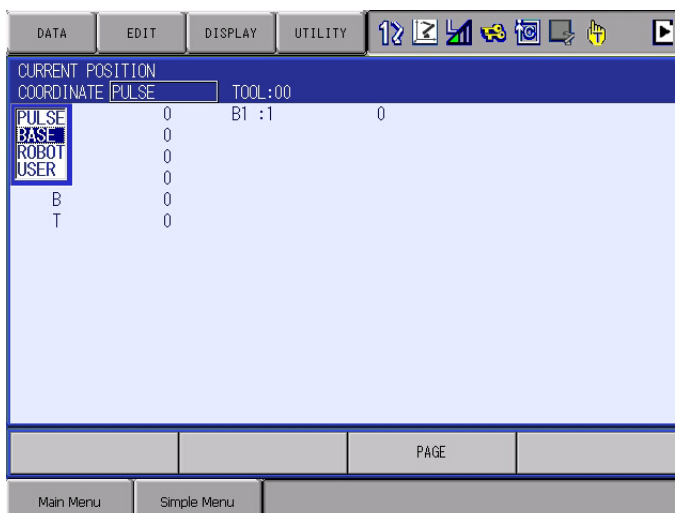

4. In the system where more than two tools are used, select tools when the monitoring is performed.
(For the details, refer to "YRC1000 GENERAL OPERATOR'S MANUAL (RE-CSO-A051) 2.3.4.1 Selecting Tool".)
5. Move the manipulator to be in the reference posture.

4 Details of Functional Safety Function
 4.5 Tool Angle Monitor Function

6. Record Rx, Ry and Rz values.



7. Set the recorded Rx, Ry and Rz values to {REF. ANGLE} on the tool angle monitoring condition file window.

2. LIMIT ANGLE

Regard the REF.ANGLE-centered tool angle, which is the object of monitoring, comprises of an appraising vector of the reference angle and the present tool angle. The approaching vector is indicated in the following ways.

- When the tool file is specified:
The vector of Z_T direction in the tool coordinates.
- When the tool file is not specified:
The vector of Z_F direction in the flange coordinates.

Fig. 4-29: Approaching Vector

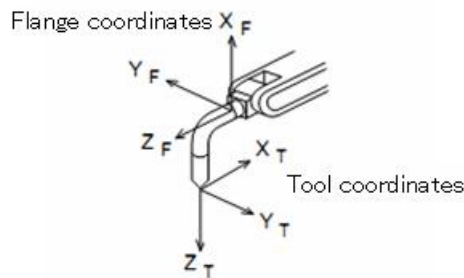

Input the upper limit of the angle θ_a which consists of the approaching vector of the reference angle over the approaching vector of the present position as the limit angle. The value from 0° to 90° can be input.

Fig. 4-30: Limit Angle of the Approaching Vector

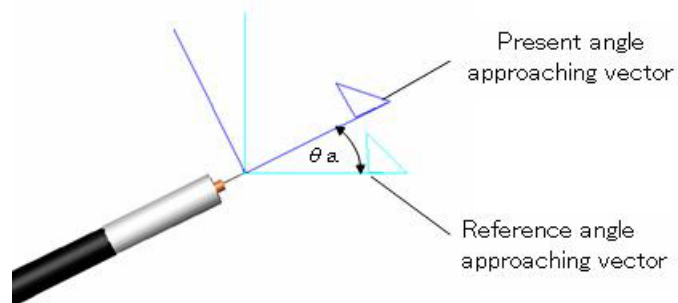

- 4 Details of Functional Safety Function
- 4.5 Tool Angle Monitor Function

4.5.4 Confirmation of Tool Angle Limit Monitor

After the tool angle monitor is specified and {READ} is pressed, it is necessary to confirm whether the monitoring is appropriately performed inside the specified angle.

"CONFIRMING" is indicated at "FILE SET STATUS" on the tool angle monitor window. Move the object manipulator to confirm whether it stops inside the specified angle.

Fig. 4-31: Window for in CONFIRMING Status

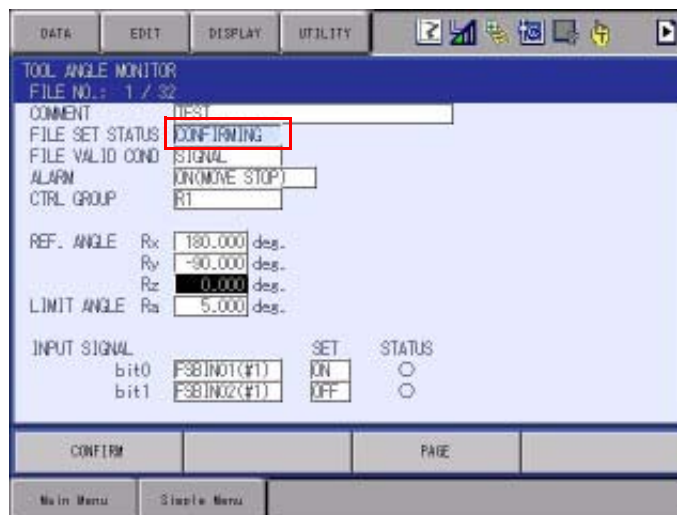

| | |
|-----|---------------------------------------|
| 4 | Details of Functional Safety Function |
| 4.5 | Tool Angle Monitor Function |

4.5.5 Starting the Tool Angle Monitor

After the manipulator is confirmed that it moves to its angle limit, press {CONFIRMED} on the window. The robot range limit function becomes valid.

Execute the practical job movement to confirm the followings.

1. Confirmation of the limit angle in the play mode

There may be following causes, in case an alarm occurred during the play back operation of the operating job.

- Specified REF. ANGLE is not appropriate
- Specified LIMIT ANGLE is not appropriate
- Teaching operation is not appropriate

Re-set REF. ANGLE or LIMIT ANGLE, or correct the teaching operation.

In case “Alarm4792: F-SAFE TOOL ANGL MONITOR ERR” or “Alarm4793: TOOL ANGL MONITOR ERR” appeared

<Cause>

The manipulator’s present posture exceeds the limit angle.

<Countermeasure>

Confirm the reference angle or the limit angle.

Modify the teaching point so that it moves inside the specified limited angle.

- 4 Details of Functional Safety Function
- 4.6 Tool Change Monitor Function

4.6 Tool Change Monitor Function

4.6.1 Outline

When performing monitoring functions of the safety such as the robot range limit function or the speed limit function in the functional safety function, appropriate tool information is required to be selected. In the system where the tool change is required, the function safety function changes the tool number in accordance with the specified value from the master CPU.

This tool change monitor function monitors whether the tool is appropriately changed. The monitoring is performed comparing the master CPU-specified tool number and the tool number which is specified to a safety signal -specified condition file. It is judged as an error when a manipulator operates when these numbers are not consistent.

Sixteen files are prepared to this function and one tool number is set to one file. This means that, for a robot group, up to 16 files can be set to monitor the tool change.

In case an error is detected, the power supply to the motor is stopped using the machine safety. And the error is notified using an alarm.



Tool change monitor function cannot be used concurrently with the tool number select function.

Follow the procedures below when starting the tool change monitor function.

1. Set the tool file.
(Before using this function, execute tool file setting by referring to *chapter 6.3 "Tool File Setting"* .)
2. Set the tool interference file.
(Before using this function, execute tool interference file setting by referring to *chapter 6.4 "Tool Interference File Setting"* .)
3. Set the tool change monitor function.
4. Confirm the tool change.
5. Start the tool change monitor function.

4 Details of Functional Safety Function

4.6 Tool Change Monitor Function

4.6.2 Tool Change Monitor Function Window

Followings are the setting procedures for the tool angle monitor function.

1. Set the security mode to the safety mode, and then select {SAFETY FUNC.} under the main menu.



2. Select {TOOL CHANGE MONITOR} under the sub menu.
 - The list of the tool change monitor status appears.

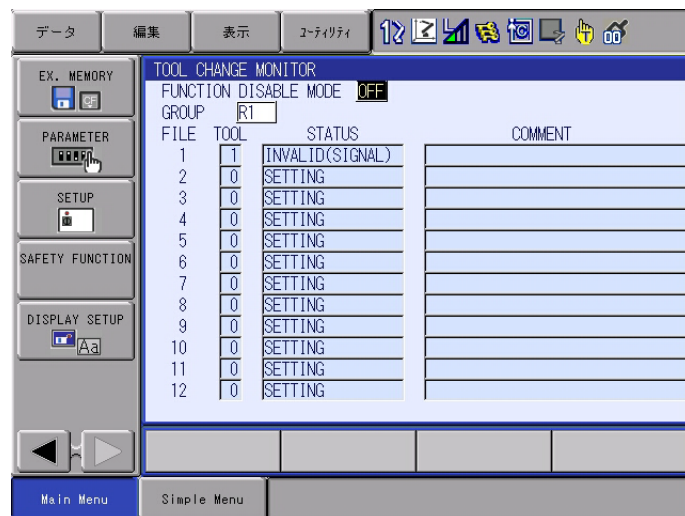

On the status list window, the 16 configuration files for the axis tool change monitor function are arranged so that their status can be confirmed. By scrolling down the window, all the list can be seen.

- 4 Details of Functional Safety Function
- 4.6 Tool Change Monitor Function

1. FUNCTION DISABLE MODE

Specify ON/OFF of the tool change monitor function. When ON is set to this item, this function can be temporarily invalidated.

| Value | Description |
|-------|---|
| OFF | The tool change monitor function is valid. |
| ON | The tool change monitor function is invalid. At the same time, playback, test-run, forward/backward operations are prohibited. |

For the details, refer to *chapter 6.1 "Function Disable Mode Setting"*.

2. GROUP

The robot group to be specified by the condition file is selected from R1 to R8 (however, only the groups set to the YRC1000).

3. FILE

The number of the individual condition file is displayed.
A robot group object file selected at "GROUP" is displayed.
Move the cursor to any number and press [SELECT]. The individual setting window for the selected condition file appears.

4. STATUS

Monitoring status of the present condition file

| Value | Description |
|------------------|--|
| SETTING | The condition file is in the initial status or in the data setting status. Not monitoring yet. |
| CONFIRMING | Confirming the area after the data is set. The status of the monitoring operation depends on the valid condition of the condition file. |
| VALID (FILE) | Data setting is completed and monitoring status of the file is in valid status. |
| INVALID (FILE) | Data setting is completed and monitoring status of the file is in invalid status. |
| VALID (SIGNAL) | Data setting is completed and monitoring status of the file is in valid status by the establishment of the safety input signal condition. |
| INVALID (SIGNAL) | Data setting is completed and monitoring status of the file is in invalid status by the disestablishment of the safety input signal condition. |

5. COMMENT

The comment input is displayed.

4 Details of Functional Safety Function

4.6 Tool Change Monitor Function

4.6.3 Tool Change Monitor Condition File Setting

On the status list window, select a file number with the cursor, and then press [SELECT].

A setting window for the selected condition file of the AXIS CHANGE MONITOR function appears.

| TOOL CHANGE MONITOR | | | |
|-----------------------------|------------------------------------|--------|----------------------------------|
| FILE NO.: 1 / 16 GROUP : R1 | | | |
| COMMENT | TEST | | |
| FILE SET STATUS | COMPLETED | | |
| FILE VALID COND | SIGNAL | | |
| ALARM | ON(MOVE STOP) | | |
| CTRL GROUP | R1 | | |
| TOOL NO. | 2 | | |
| DETECTION DELAY TIME | 1.00 sec | | |
| INPUT SIGNAL | SET | STATUS | |
| bit0 | F5BIN01(#1) | ON | <input checked="" type="radio"/> |
| bit1 | F5BIN02(#1) | OFF | <input type="radio"/> |
| bit2 | MS-OUT01 | ON | <input type="radio"/> |
| bit3 | ----- | **** | <input type="radio"/> |
| OUTPUT SIGNAL | F5BOUT07(#1) <input type="radio"/> | | |
| | | | PAGE |

By scrolling down the window with the cursor, all the items can be seen.

<Details of the Window>

In this section, only the items inherent to tool change monitor function are explained. For the items not mentioned here, please refer to *chapter 4.8 "Common Setting Item for the Condition File"*.

1. TOOL NO.

For confirming the tool number, specify a tool number which is specified to the functional safety function, when this file is selected.

2. DETECTION DELAY TIME

Specify a time frame from validating the condition file to start the alarm detection. It is detected as an error in case a tool change monitor condition file is selected and one of the following conditions are met after the time specified in {DETECTION DELAY TIME} is passed.

The followings are the error judging conditions in the tool change monitoring function.

- All the condition files for one robot group are invalidated.
- Two or more condition files for one robot group are simultaneously validated.
- The manipulator is in operation while a tool number specifying value and the tool number specifying value of the validated condition files are not consistent.

| | |
|-----|---------------------------------------|
| 4 | Details of Functional Safety Function |
| 4.6 | Tool Change Monitor Function |

4.6.4 Confirmation of Tool Change Monitor

After the setting of the condition file and {READ} is pressed, it is necessary to confirm whether the monitoring is appropriately performed by the specified tool.

“CONFIRM” is indicated on the tool change window. “VALID” the file and change the tool, and then move the object manipulator to confirm whether a alarm occurs.

NOTE

An alarm for the tool change monitor function occurs only when the manipulator is in motion. (If it is in stop status, monitoring is still performed but the alarm does not occur.)

However, once an alarm occurs, it keeps sounding unless the problem is solved even the manipulator stops.



CAUTION

- Make sure that the robot is in a stopped state when performing a tool-file change.
If the tool-file change is performed during a robot program operation, the following may result:
 - Danger caused by selecting an incorrect tool
 - The manipulator’s motion speed exceeding the speed limit if the types of the tools before and after the change are significantly different

4.6.5 Starting the Tool Change Monitor

After the tool change is confirmed, press {CONFIRMED} on the window. The tool change monitor function becomes valid.



CAUTION

- By a tool change, an monitoring error may be detected in the robot range limit function due to the change of tool model or TCP. For this reason, when changing a tool, specify appropriate range of motions for the object tool.

4 Details of Functional Safety Function
4.6 Tool Change Monitor Function

4.6.6 When Using the Tool Change Monitor Function

When using the tool change monitor function, this function should be validated in the maintenance mode.

Follow the procedures below.

1. Select {SYSTEM} under the main menu, and then select {SECURITY} to change the security mode to the safety mode.



2. Select {SYSTEM} under the main menu, and then select {SET} under the sub menu.

– The SETUP window appears.

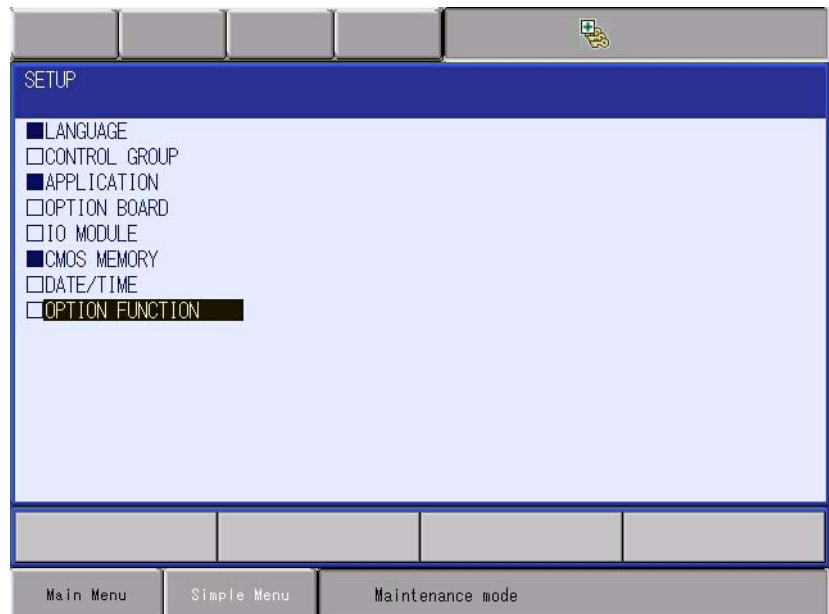

4 Details of Functional Safety Function
 4.6 Tool Change Monitor Function

3. Select "OPTION FUNCTION", "Functional safety" and "DETAIL".

– The Functional safety window appears.

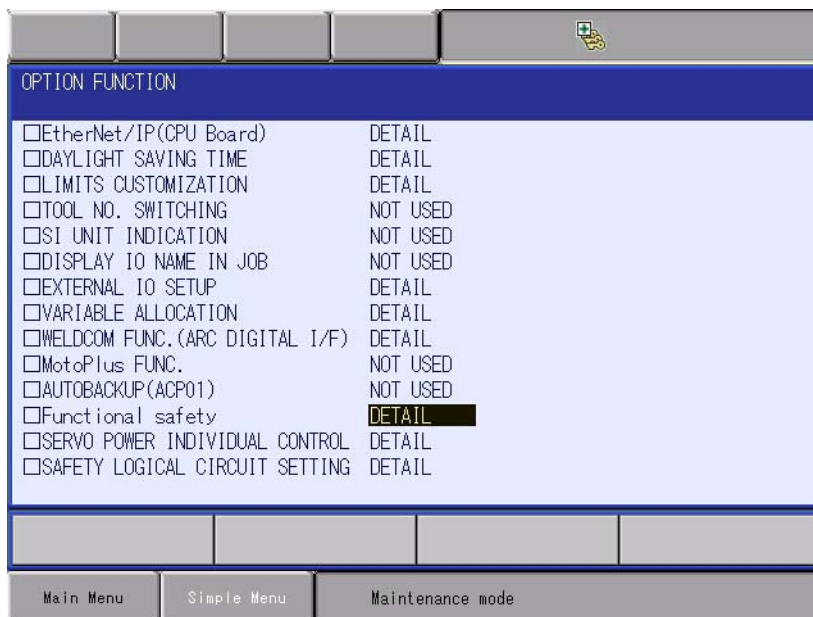

4. Change to set {USED (CHANGE MONITOR)} for the item at {Tool change monitor/Tool number select}.

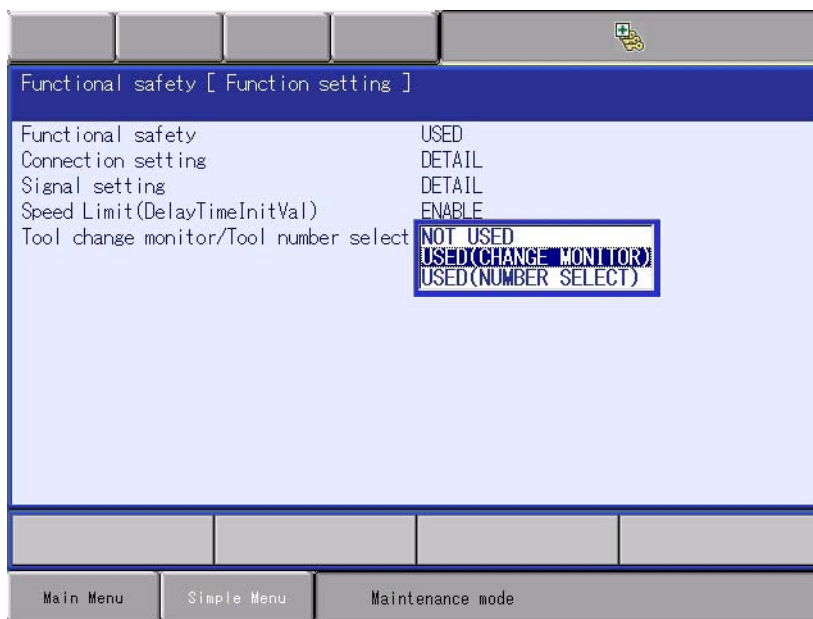

4 Details of Functional Safety Function

4.6 Tool Change Monitor Function

5. Press [ENTER], and a dialog box asking "Modify?" appears.
 - Select "YES".
 - After changing, a dialog box asking "Initialize related files?" may appear.
 - If the setting related to functional safety has already specified, select "NO", if not, select "YES".

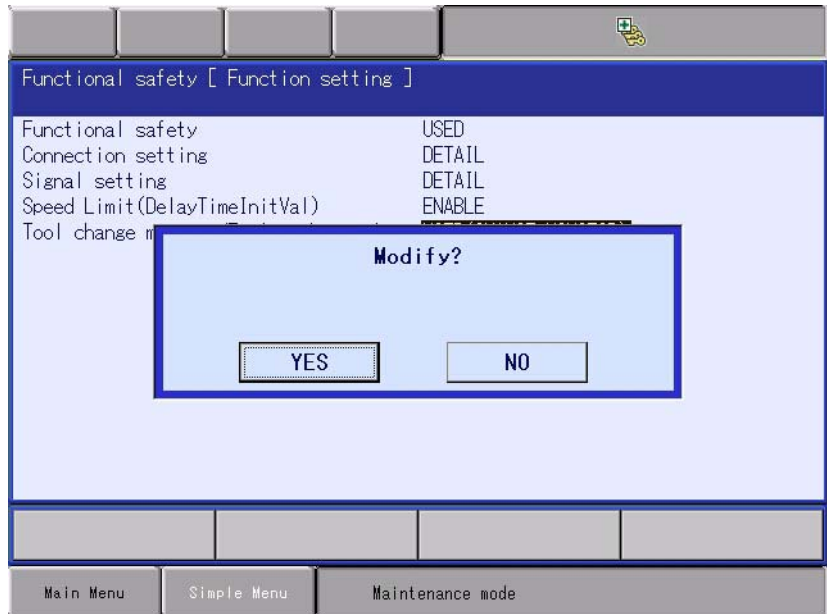

- Select "YES", and a dialog box asking "Initialize related files?" appears.
- If the setting related to functional safety has already specified, select "NO". (When "YES" is selected, the setting related to functional safety will be initialized.)

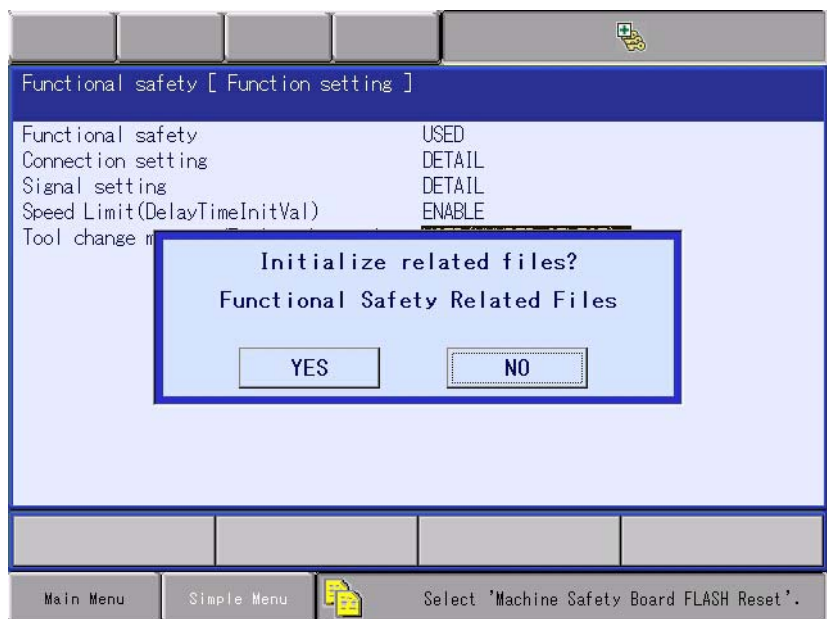

4 Details of Functional Safety Function
4.6 Tool Change Monitor Function

6. Select {FILE} under the main menu, and then select {INITIALIZE} under the sub menu.

– The INITIALIZE window appears.

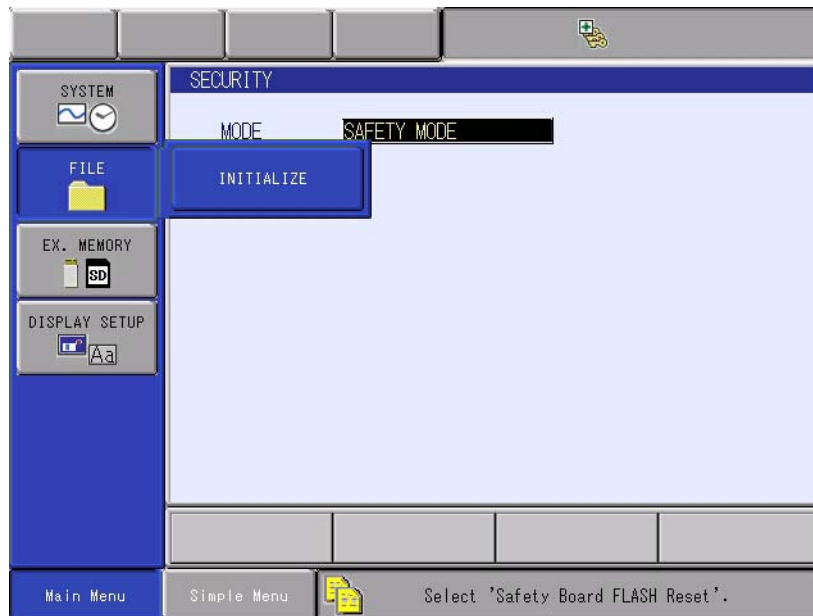

7. Move the cursor and select "Safety Board FLASH Reset" on the window.

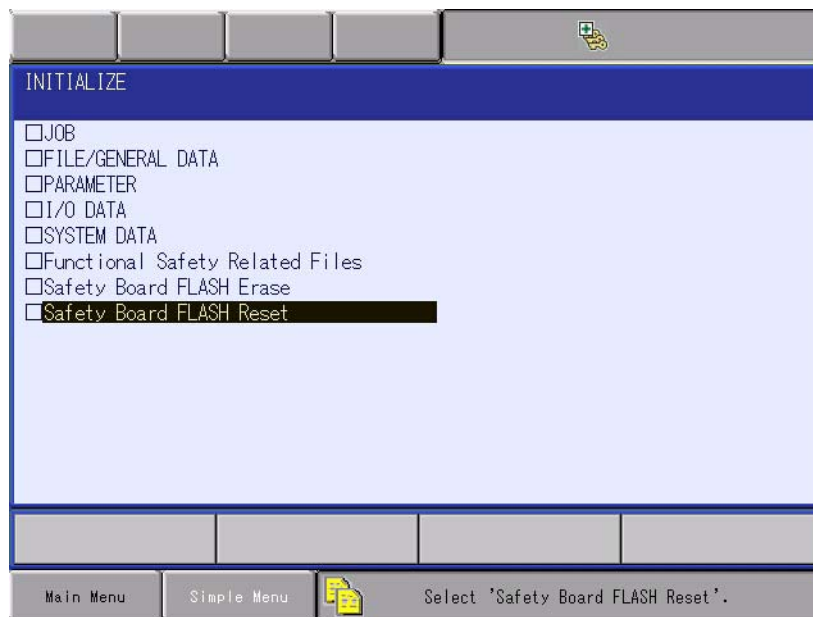

4 Details of Functional Safety Function

4.6 Tool Change Monitor Function

8. Select "YES" when a window shown below appeared.
- Data of the safety circuit board is reset. When resetting is completed, a beep sounds in a few seconds.

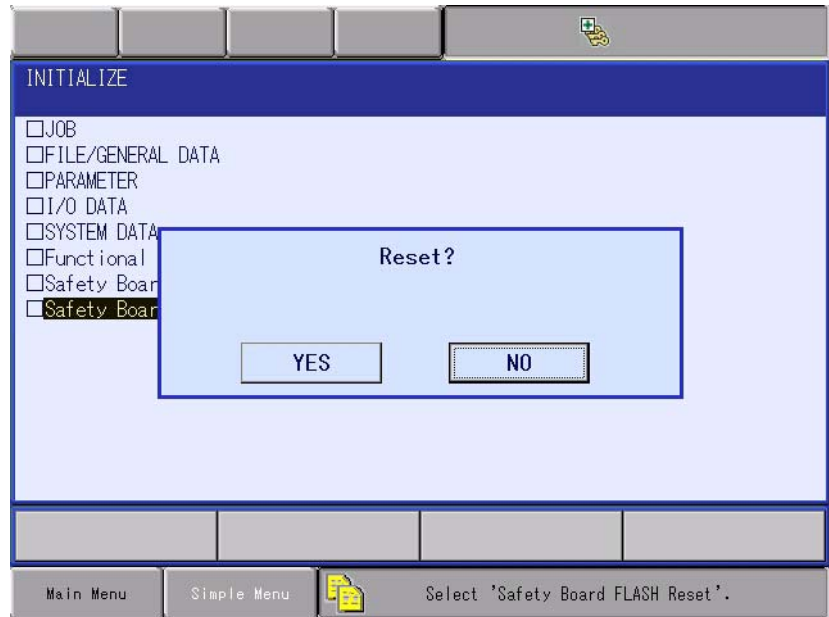

9. Turn ON the controller power supply.

The following alarm may occur at the first start-up and operation of the manipulator after validating the tool change monitor function because all the tool change files are not specified yet.

“Alarm 4789: F-SAFE TOOL CHANGE MONITOR ERR”

Perform the tool change condition file settings, validate the tool change monitoring function and reset the alarm.



CAUTION

- The tool change monitoring function is set to invalid at the default status. For the appropriate safety monitoring, be sure to validate the function and perform the monitoring. This monitoring should be set valid to monitor that the tool is not changed even if the tool file is not changed.

| | |
|-----|---------------------------------------|
| 4 | Details of Functional Safety Function |
| 4.7 | Tool Number Selection Function |

4.7 Tool Number Selection Function

4.7.1 Outline

When performing monitoring functions of the safety such as the robot range limit function or the speed limit function in the functional safety function, appropriate tool information is required to be selected. This tool number selection function selects the tool number used in functional safety based on the safety signal.



Tool number selection function cannot be used concurrently with the tool change monitor function.

Functional safety uses the tool number set in the condition file specified by the safety signal. It is judged as an error when a manipulator operates over a certain distance when the tool number is not selected or multiple tool numbers are selected.

Sixteen files are prepared to this function and one tool number is set to one file. This means that, for a robot group, up to sixteen files can be set to select the tool number. In case an error is detected, the power supply to the motor is stopped using the machine safety board. And the error is notified using an alarm.



To maintain Safety Category 3 and PL-d in the safety monitoring in the functional safety function, the safety signal to be used must meet the requirements of Safety Level SIL2 and PL-d.



CAUTION

- Connect the safety signal used to select the tool number so that the tool connected to the manipulator can be specified by the pattern of the safety signal. When an alarm occurs, confirm the connection of the safety signal.
- Also, consider sufficiently that the correct tool number is selected based on the connection of the safety signal, and the robot range limit function and the speed limit function operate properly.

If an incorrect tool number is selected, the safety of the robot range limit function and the speed limit function may be impaired.

4 Details of Functional Safety Function
4.7 Tool Number Selection Function

Follow the procedures below when setting the tool number selection.

- (1) Set the tool file.
(Before using this function, execute tool file setting to select by referring to *chapter 6.3 "Tool File Setting"* .)
↓
- (2) Set the tool interference file.
(The selected tool is necessary to perform the robot range limit function. Before using this function, execute tool interference file setting by referring to *chapter 6.4 "Tool Interference File Setting"* .)
↓
- (3) Set the tool number selection condition file.
↓
- (4) Confirm the tool number selection.
↓
- (5) Start the tool number selection.

4 Details of Functional Safety Function
 4.7 Tool Number Selection Function

4.7.2 Tool Number Selection Function Window

Followings are the setting procedures for the tool number selection function.

1. Change the mode to the security mode, and then press {SAFETY FUNC.} under the main menu.



2. Press {TOOL NUBMER SELECTION} in the sub menu.
 - The list of the tool number selection status appears.

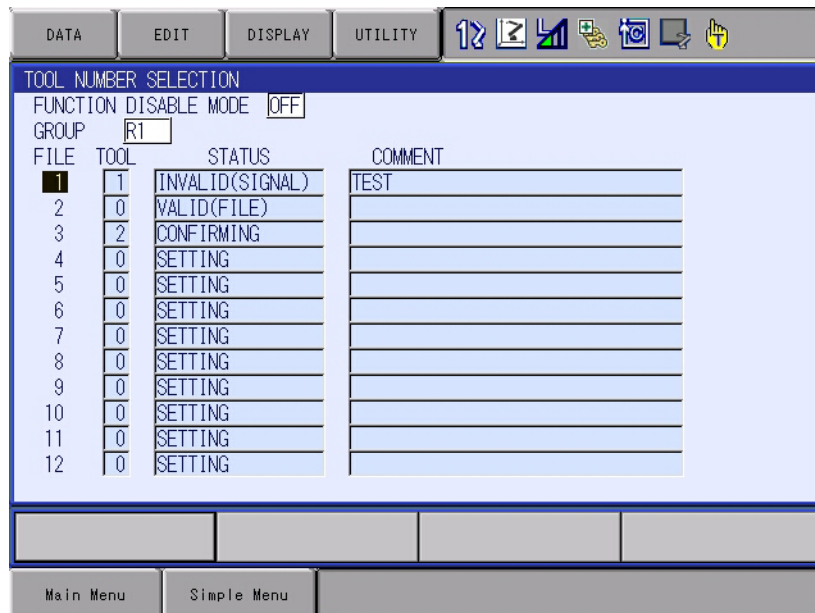

On the status list window, the sixteen setting files for the tool number selection function are arranged so that their status can be confirmed. By scrolling down the window, all the list can be seen.

4 Details of Functional Safety Function

4.7 Tool Number Selection Function

Followings are the details of the item on the window.

<Details of the Window>

1. {FUCTION DISABLE MODE}

Specify ON/OFF of the tool number selection function. When ON is set to this item, this function can be temporarily invalidated.

| Value | Meaning |
|-------|---|
| OFF | The tool number selection function is valid. |
| ON | The tool number selection function is invalid. At the same time, playback, test-run, forward/backward operations are prohibited. |

For the details, refer to *chapter 6.1 "Function Disable Mode Setting"*.

2. {GROUP}

The robot group to be specified by the condition file is selected from R1 to R8 (however, only the groups set to the YRC1000).

3. {FILE}

The number of the individual condition file is displayed. A robot group object file selected at {GROUP} is displayed. Move the cursor to any number and press [SELECT]. The individual setting window for the selected condition file appears.

4. {STATUS}

Monitoring status of the present condition file is indicated.

| Value | Meaning |
|------------------|--|
| SETTING | The condition file is in the initial status or in the data setting status. The tool number is not selected yet. |
| CONFIRMING | Confirming the area after the data is set. The tool number to be selected depends on the valid condition of the condition file. |
| VALID (FILE) | Data setting is completed and the tool number selection by using the condition file is in valid status. |
| INVALID (FILE) | Data setting is completed and the tool number selection by using the condition file is in invalid status. |
| VALID (SIGNAL) | Data setting is completed and the tool number selection by using the condition file is in valid status by the establishment of the safety signal condition. |
| INVALID (SIGNAL) | Data setting is completed and the tool number selection by using the condition file is in invalid status by the disestablishment of the safety signal condition. |

4 Details of Functional Safety Function

4.7 Tool Number Selection Function

4.7.3 Tool Number Selection Condition File Setting

- On the status list window, select a file number with the cursor, and then press [SELECT].
 - A setting window for the selected condition file of the tool number selection function appears.

| FILE NO.: | 1 / 16 | GROUP : | R1 |
|----------------------|----------------|---------|--------|
| COMMENT | TEST | | |
| FILE SET STATUS | COMPLETED | | |
| FILE VALID COND | SIGNAL | | |
| ALARM | ON(MOVE STOP) | | |
| CTRL GROUP | R1 | | |
| TOOL NO. | 2 | | |
| DETECTION DELAY TIME | 1.00 sec | | |
| INPUT SIGNAL | | SET | STATUS |
| bit0 | FSBIN01(#1) | ON | ● |
| bit1 | FSBIN02(#1) | OFF | ● |
| bit2 | ----- | **** | ○ |
| bit3 | ----- | **** | ○ |
| OUTPUT SIGNAL | FSBOUT07(#1) ○ | | |

By scrolling down the window with the cursor, items which are not displayed on the window can be seen.

<Details of the Window>

In this section, only the items inherent to the tool number selection function are explained. For the items not mentioned here, please refer to *chapter 4.8 "Common Setting Item for the Condition File"*.

1. {TOOL NO.}

Specify a tool number which is specified to the functional safety function, when this file is selected.

2. {DETECTION DELAY TIME}

Specify a time frame from validating the condition file to start the alarm detection. It is detected as an error in case a tool number selection condition file is selected and one of the following conditions are met after the time specified in {DETECTION DELAY TIME} is passed.

The followings are the error judging conditions in the tool number selection function.

- All the condition files for one robot group are invalidated.
- Two or more condition files for one robot group are simultaneously validated.

4.7.4 Confirmation of Tool Number Selection

After the setting of the condition file and {WRITE} is pressed, it is necessary to confirm whether the tool is correctly selected. "CONFIRM" is indicated on the tool number selection window. "VALID" the file and move the object manipulator to confirm whether an alarm occurs.



An alarm for the tool number selection function occurs only when the manipulator is in motion. (If it is in stop status, the alarm does not occur.)
However, once an alarm occurs, it keeps sounding unless the problem is solved even the manipulator stops.



CAUTION

- Perform selecting the tool number while the manipulator is stop status or there may following dangers when it is performed while the manipulator is in operating status.
 - Wrong tool may be selected.
 - The manipulator motion speed exceeds the speed limit in case the tool before the change and after the change differs widely.

4.7.5 Starting the Tool Number Selection

After the tool number selection is confirmed, press {CONFIRMED} on the window. The tool number selection function becomes valid.



CAUTION

- By a tool number selection, a monitoring error may be detected in the robot range limit function due to the change of tool model or TCP.
For this reason, when selecting a tool, specify appropriate range of motions for the object tool.

- 4 Details of Functional Safety Function
- 4.7 Tool Number Selection Function

4.7.6 When Using the Tool Number Selection Function

When using the tool number selection function, this function should be validated in the maintenance mode.
Follow the procedures below.

1. Press {SYSTEM} under the main menu, and then press {SECURITY} to change the mode to the security mode.



2. Press {SYSTEM} under the main menu. And then, press {SET} in the sub menu.

– SETUP window appears.

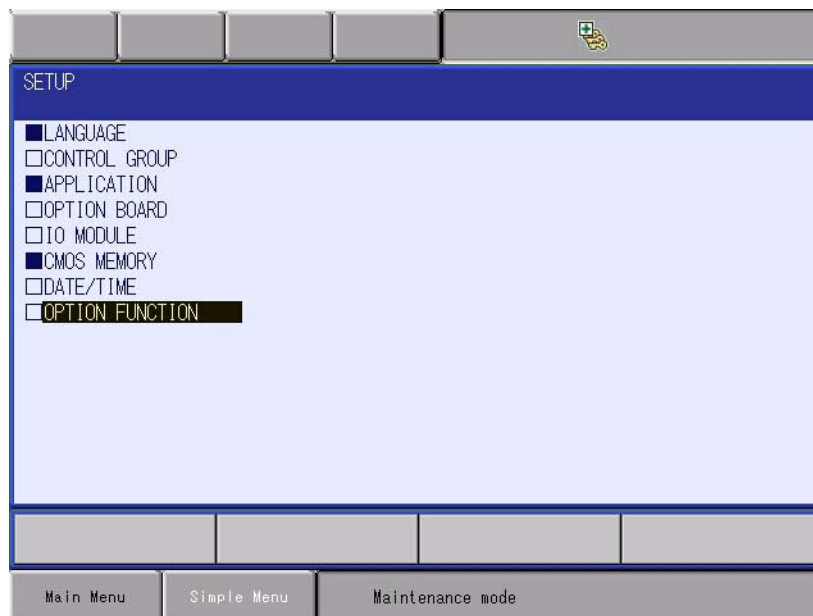

4 Details of Functional Safety Function
 4.7 Tool Number Selection Function

3. Select {OPTION FUNCTION}, {Functional safety} and “DETAIL”.
 – Functional safety window appears.

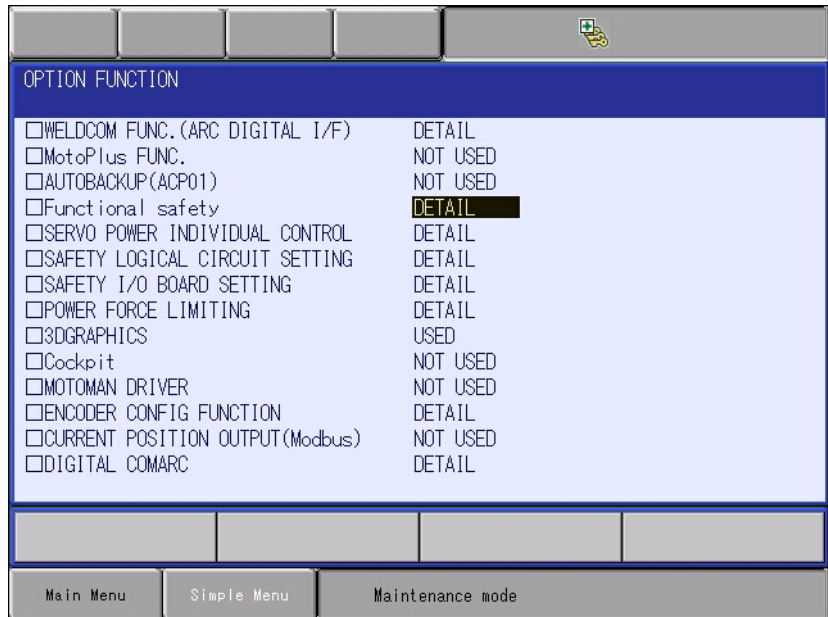

4. Change to set “USED (NUMBER SELECT)” for the item at {Tool change monitor/Tool number select}.

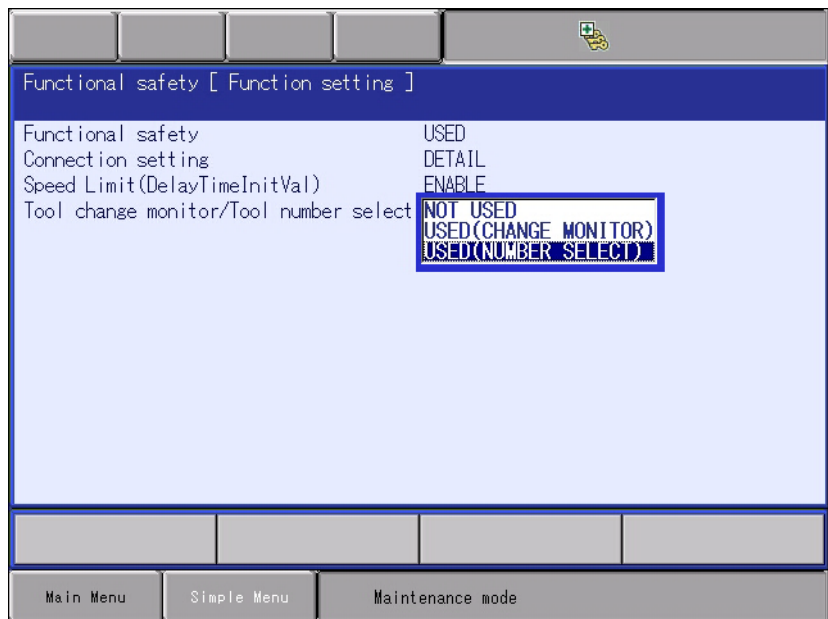

4 Details of Functional Safety Function
 4.7 Tool Number Selection Function

5. Press [ENTER], and a dialog box asking “Modify?” appears.
 - Select “YES”.
 - After changing, a dialog box asking “Initialize related files? Functional Safety Related Files” may appear.
 - If the setting related to functional safety has already specified, select “NO”, if not, select “YES”.

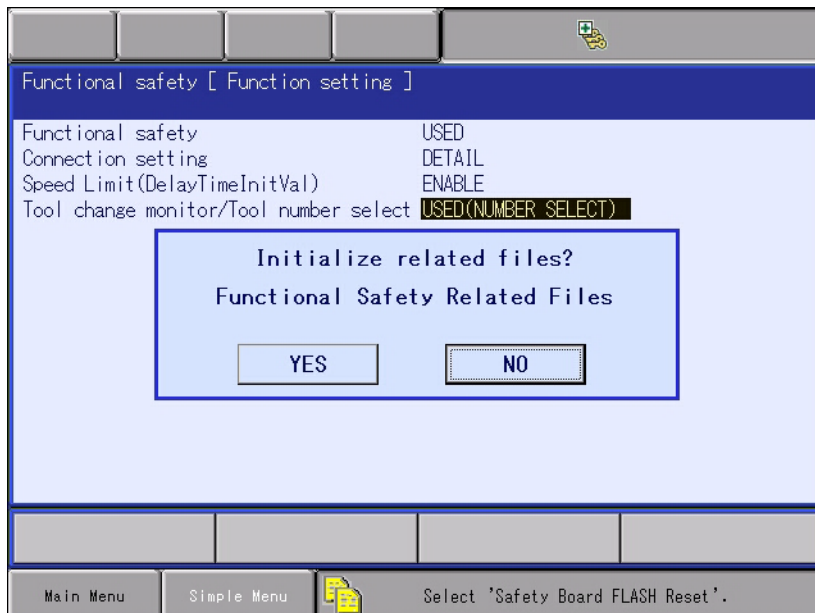
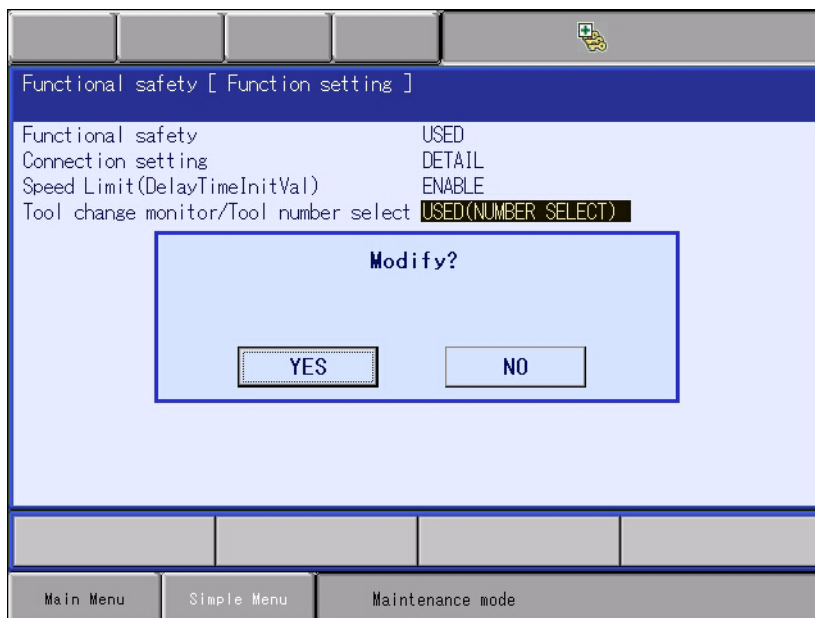

4 Details of Functional Safety Function
 4.7 Tool Number Selection Function

6. Press {FILE} under the main menu. And then, press {INITIALIZE} in the sub menu.
 - A window for initialization appears.

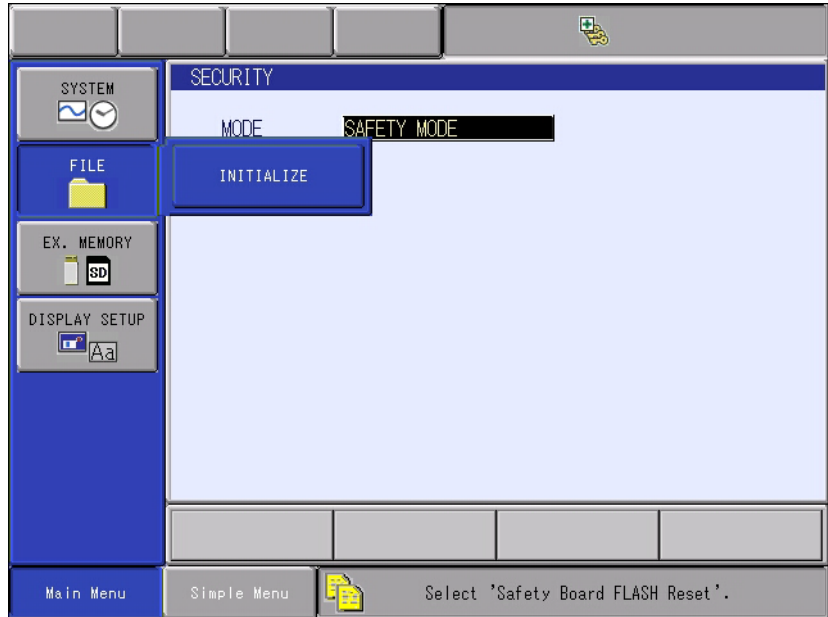

7. Move the cursor and select "Functional Safety Board FLASH Reset" on the window.

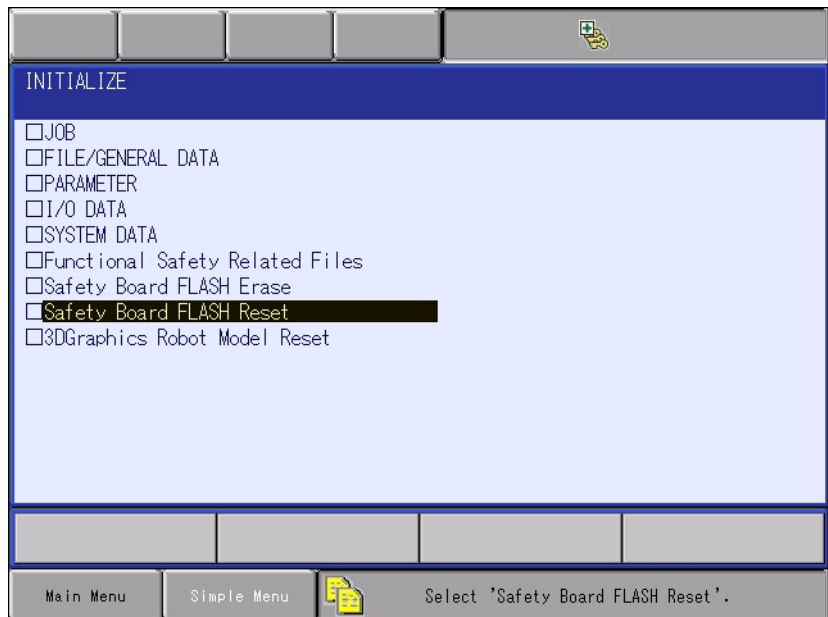

4 Details of Functional Safety Function
 4.7 Tool Number Selection Function

8. Select "YES" when a window shown below appeared.
 – Data of the functional safety board is reset. When resetting is completed, a buzzer sounds in a few seconds.

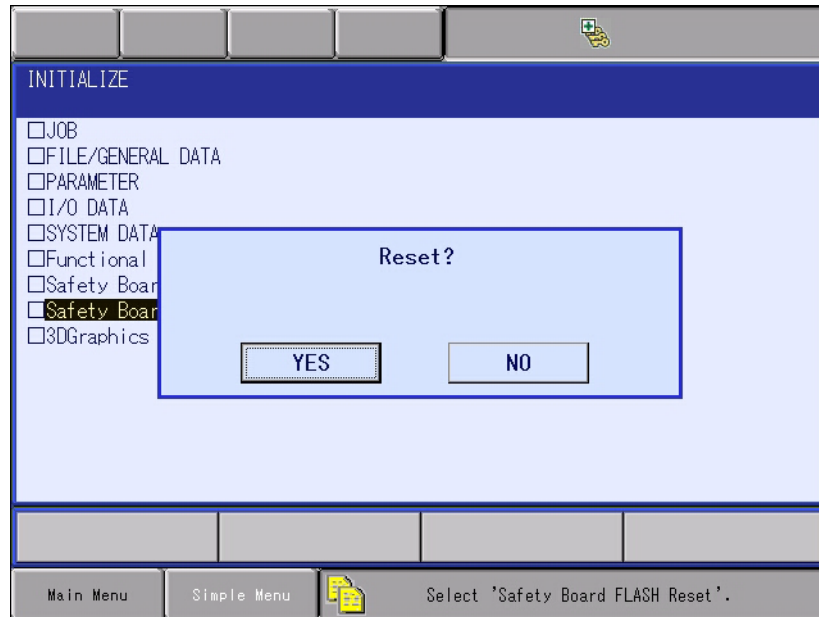

9. Turn ON the controller power supply.

Following alarm may occur at the first start-up and operation of the manipulator after validating the tool number selection function because all the tool number selection files are not specified yet.

“Alarm 4789: F-SAFE TOOL CHANGE MONITOR ERR”

Perform the tool number selection file settings, validate the tool number selection function and reset the alarm.

CAUTION

- The tool number selection function is set to invalid at the default status. For the appropriate safety monitoring, be sure to validate either of the tool change monitor function or the tool number selection function and perform the monitoring.

4.8 Common Setting Item for the Condition File

Although the condition files of the functional safety function exist by functions, there are common setting items to many files such as VALID/INVALID of the file.

Here, in this chapter, details of the common items are explained. For the safety signal settings, refer to *chapter 5 "Safety Signal"*.

The AXIS RANGE LIMIT window is used as an example.



<Details of the Window>

1. COMMENT

The comment input is displayed.

COMMENT can be specified in the condition file of any function.

2. FILE SET STATUS

Status of the present condition file

| Value | Description |
|------------|---|
| SETTING | The condition file is in the initial status or in the updating status. When the data is changed by the read back operation, select {WRITE} in the window, the data writing to the safety circuit board is completed, and then this changes to "CONFIRMING" or "COMPLETED". |
| CONFIRMING | <p>The data is appropriately set and the limit area can be confirmed after the file validating conditions are met. Select {COMFIRM} in the window after the area is confirmed. "COMPLETED" is indicated when the data setting process in the safety circuit board is completed.</p> <p>In case the data is changed at this timing, the indication changes to "CONFIRMING".</p> <p>Only the files mentioned below exist while "CONFIRMING" is indicated.</p> <ul style="list-style-type: none"> • Axis range limit function • Robot range limit function • Tool angle monitor function • Tool change monitor function • Tool number select function |
| COMPLETED | The condition file setting is completed. The safety monitoring can be performed after the file validating conditions are met. In case the data is changed at this timing, the indication changes to "CONFIRMING". |

FILE SET STATUS is displayed in the condition file of any function.

- 4 Details of Functional Safety Function
 4.8 Common Setting Item for the Condition File

3. FILE VALID COND

Specify the conditions for validating the monitoring of the object files. However, to validate the monitoring, condition file data should be appropriately specified. The settings at this item might be ignored in case "SETTING" is indicated at "FILE SET STATUS".

| Value | Description |
|---------|---|
| INVALID | Always invalidate the object file. |
| VALID | Always validate the object file. |
| SIGNAL | Judge valid/invalid by referring the safety input signal. For the details of the safety signal usage, refer to <i>chapter 5 "Safety Signal"</i> . |

{FILE VALID COND} can be specified in the condition file of any function. In the tool change monitor function and the tool number select function, only one condition file will be valid in the normal status. Therefore, when setting {FILE VALID COND}, if the other condition file has been set to "VALID", a confirmation dialog box appears.

The confirmation dialog box can be displayed in the system software version YAS2.82.00A(□)-00 or later.

4. ALARM

Select alarm or not alarm to the monitoring result of the object file.

| Value | Description |
|-----------------|--|
| ON (MOVE STOP) | Servo is turned OFF with an alarm when an error occurs under the object file monitoring condition. |
| OFF (CONT MOVE) | Although monitoring is performed under the object file condition, alarm does not occur and the servo is not turned OFF even if a monitoring error occurred. The monitoring result can be obtained by the safety output signal. |

The tool change monitor function and the tool number select function can be displayed and set in the system software version YAS2.82.00A(□)-00 or later.



DANGER

- When "OFF" is set to ALARM, the functional safety function does not stop the manipulator operation even if a monitoring error is detected in the object file. In this regard, before operating the manipulator, sufficiently consider possible risks attributed to the alarmless operation (risk assessment) and take necessary measures to them.

-
- 4 Details of Functional Safety Function
 - 4.8 Common Setting Item for the Condition File
-

5. GROUP

Specify the control group to be monitored specified by the condition file.

Selectable control groups vary depending on the function.

| Function | Selectable control group |
|------------------------------|---|
| Axis range limit function | Robot, Base, Station group |
| Axis speed monitor function | Robot, Base, Station group |
| Robot range limit function | Robot group |
| Speed limit function | Robot, Station group |
| Tool angle monitor function | Robot group |
| Tool change monitor function | The group is fixed by files. When modifying the object group, change it on the list of tool change monitor function window. |
| Tool number select function | The group is fixed by files. When modifying the object group, change it on the list of tool number select function window. |

5 Safety Signal

For the functional safety function, the safety monitoring condition files can be switched by the safety input signal.

Also, this function corresponds the outputting of the monitoring result by the safety output signal.

Followings are the safety signal available for the functional safety function.

| Signal | Signal point | Note |
|--|---|--|
| Functional safety general-purpose signal | (for JANCD-ASF02-E) Input: 8 points/terminal Output: 8 points/terminal | The functional safety general-purpose signal is connected per safety circuit board. The number of the signals differ depending on the board: · when connecting to "JANCD-ASF02-E", 8 input points and 8 output points · when connecting to "JZNC-ASU03-E", 16 input points and 16 output points |
| | (for JZNC-ASU03-E) Input: 16 points/terminal Output: 16 points/terminal | |
| Safety fieldbus signal | Input: 64 points/system Output: 64 points/system | The safety fieldbus signal is connected per system. Depending on the settings, up to 64 points can be used from one safety circuit board. The safety fieldbus is an optional function other than the functional safety. |
| Safety logic circuit extended signal | Input: 64 points/system Output: 64 points/system | The safety logic circuit extended signal (64 input points and 64 output points) is connected per system. The output of the safety logic circuit (MS-OUT) can be used as the input of the functional safety. The output of the functional safety (FS-OUT) can be used as the input of the safety logic circuit. |



To maintain Safety Category 3 and PL-d in the safety monitoring using the functional safety function, the safety signal to be used must meet the requirements of Safety Level SIL2 and PL-d.

If the safety fieldbus signal and the safety logic circuit signal are included, up to 144 points can be used from one safety circuit board.

To condition files, as many safety signals as desired can be allocated within the possible signal points, thus signals are flexibly used even if the board has small numbers of signal points.

Follow the procedures below when using the safety signals:

1. Perform the allocation of the functional safety general-purpose signal.
2. Perform the allocation of the safety logic circuit signal.
(This is not necessary when using only the functional safety general-purpose signal.)
3. Perform the allocation of the safety fieldbus signal.
(This is necessary when using the safety fieldbus signal.)
4. Set the condition file.

5 Safety Signal
 5.1 Allocation of Safety Logic Circuit Extended Signal

5.1 Allocation of Safety Logic Circuit Extended Signal

The safety logic circuit extended signal can be used as the input signal or the output signal of the functional safety. The number of the signal points are 64 input points and 64 output points. These signals are shared by the whole system, and can be used from any board of the safety circuit board. Regarding the FS-OUT (safety logic circuit functional safety output signal), allocation of the signal and the board must be performed in advance.

For details of the safety logic circuit function, refer to “YRC1000 INSTRUCTIONS (RE-CTO-A221) 8.26 Safety Logic Circuit”.

1. Set the security mode to the safety mode, and then select {SAFETY FUNC.} under the main menu.

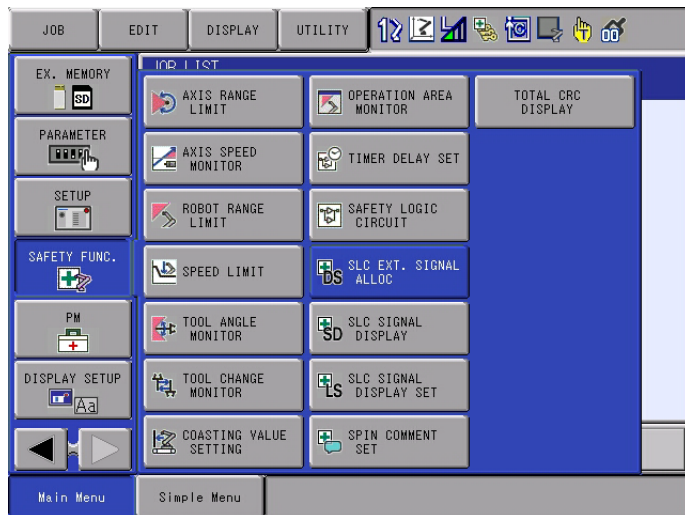

2. Select {SLC EXT. SIGNAL ALLOC} under the submenu.
 - The settings window of the safety logic circuit signal allocation appears.

Allocation of FS-OUT (functional safety output signal)

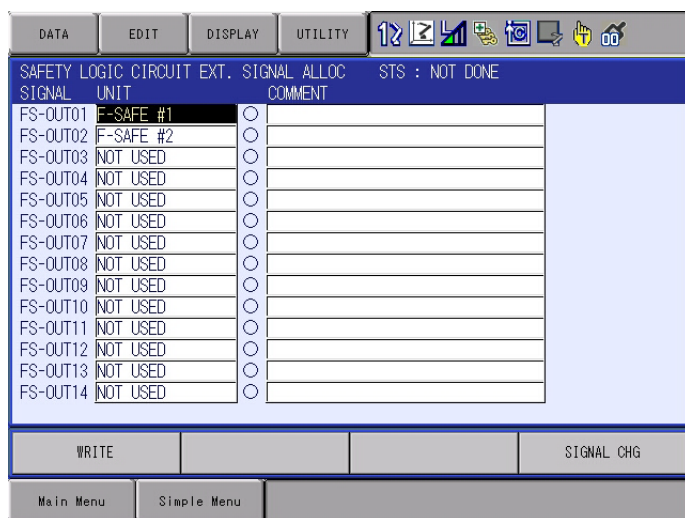

<Details of the Window>

1. SIGNAL

Indicates the signal number (FS-OUT01 to 64).

-
- 5 Safety Signal
 - 5.1 Allocation of Safety Logic Circuit Extended Signal
-

2. UNIT

The destination of the FS-OUT is selected from the following:

- I) Not used
- II) One of the functional safety (F-SAFE) #1 to #8

To prevent the duplicate use of an output signal (FS-OUT), one signal is allocated to one board in which the signal is used.

5.2 Allocation of Safety Fieldbus Signal

The safety fieldbus function is not a functional safety function but an optional function. When it is valid, the safety fieldbus signal can be used in the functional safety function.

Safety fieldbus signal transmits/receives the safety-guaranteed “safety data” through the fieldbus communication path. It has 64 input signal points and 64 output signal points.

These signals are commonly used in the whole system and thus they can be referred from both machine safety board and functional safety board. In this consequence, “SAFETY SIG. BOARD ALLOC” function is prepared to define which signal is to be used in which board.

1. Set the security mode to the safety mode, and then select {SAFETY FUNC.} under the main menu.

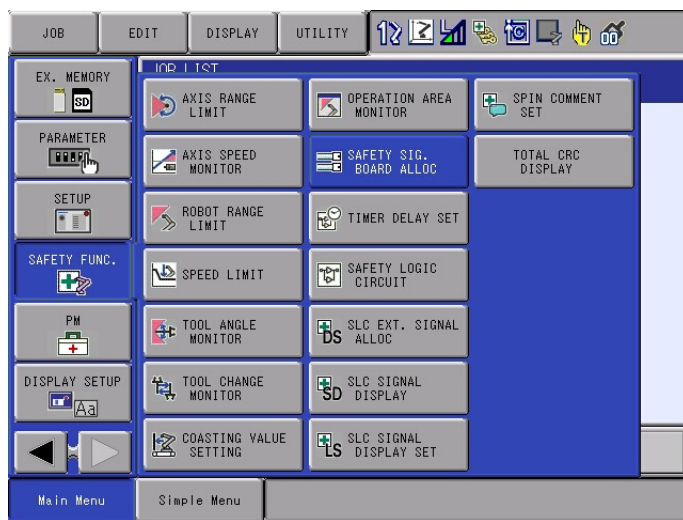

2. Select {SAFETY SIG. BOARD ALLOC} in the sub menu.
 - The settings window of the safety signal board allocation appears.

Allocation of output signal

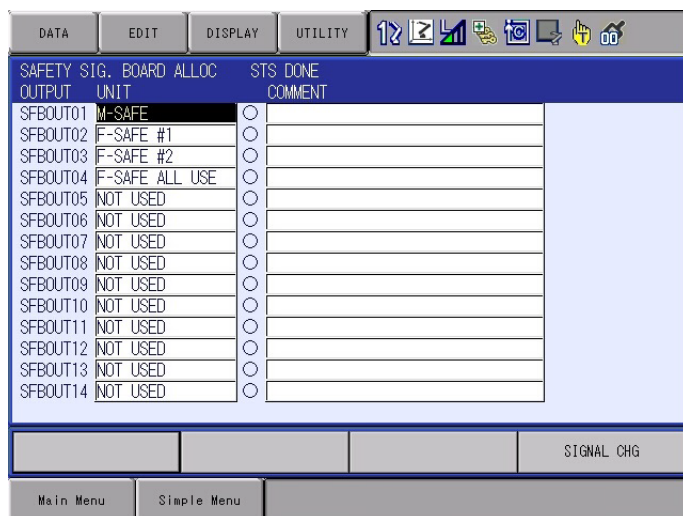

- 5 Safety Signal
 5.2 Allocation of Safety Fieldbus Signal

<Details of the Window>

1. OUTPUT

Indicates the signal number.

2. UNIT

The destination of the safety fieldbus output signal is selected from the following:

- I) Not used
- II) Machine safety (used in the safety logic circuit)
- III) One of the functional safety (F-SAFE) #1 to #8
(used in the functional safety (specify the terminal to use))
- IV) All of the functional safety
(used in the whole safety circuit board where the functional safety is enabled)

To prevent the duplicate use of a safety signal, one signal is allocated to one board basically.

| Item | Description |
|---------------------------------------|--|
| Not used | The signal is not used. |
| Machine safety | The signal can be used in the safety logic circuit. |
| One of the functional safety #1 to #8 | The signal can be used in the functional safety (one of the terminals from 1 to 8) |
| Functional safety ALL USE | The signal can be used in the whole safety circuit board where the functional safety is enabled. |

5 Safety Signal

5.3 Settings of Safety Function Condition File

5.3 Settings of Safety Function Condition File

A window for setting signals are prepared to all the condition files.

Axis range limit function window is shown below as an example of signal setting window.

| INPUT SIGNAL | | SET | STATUS |
|---------------|--------------|-----|----------------------------------|
| bit0 | FSBIN01(#1) | OFF | <input checked="" type="radio"/> |
| bit1 | FSBIN02(#1) | ON | <input checked="" type="radio"/> |
| bit2 | SFBIN01 | ON | <input type="radio"/> |
| bit3 | MS-OUT01 | OFF | <input type="radio"/> |
| bit4 | ----- | *** | <input type="radio"/> |
| OUTPUT SIGNAL | FSBOUT01(#1) | | <input type="radio"/> |

<Details of the Window>

1. INPUT SIGNAL

To validate an object condition file, specify a safety input signal for reference.

Same input signal cannot be specified in the same condition file. The already-specified signal does not appear in the selection list in the same condition file.

| Value | Description |
|-------------------------|--|
| NO CONFIG | Signal is not specified. |
| FSBIN01 to FSBIN16 | Specify the functional safety general-purpose input signal. The number of the signal points differs depending on the safety I/O board to be connected. When the ASF02 board is connected, the signals 1 to 8 are used, and when the ASU03 unit is connected, the signals 1 to 16 are used. (# n): terminal number of the safety circuit board |
| SFBIN01 to SFBIN64 | Specify the safety fieldbus input signal. (signal 1 to 64) |
| MS-OUT01 to MS-OUT64 | Specify the machine safety output signal of the safety logic circuit. (signal 1 to 64) |

“INPUT SIGNAL” can be specified in the condition file of any function. To perform settings of “INPUT SIGNAL”, set “SIGNAL” for “FILE VALID COND”.

5 Safety Signal
5.3 Settings of Safety Function Condition File

2. SET

To the input value of the signal selected at “INPUT SIGNAL”, specify either ON or OFF for satisfying the condition to set valid.

| Value | Description |
|-------|--|
| OFF | The valid condition is satisfied when the value set at “INPUT SIGNAL” becomes OFF. |
| ON | The valid condition is satisfied when the value set at “INPUT SIGNAL” becomes ON. |

“SET” can be specified in the condition file of any function.
To perform settings of “SET”, set “SIGNAL” for “FILE VALID COND”.

3. STATUS

The present input value of the signal input at “INPUT SIGNAL”

| Value | Description |
|-------|---|
| ○ | The present input value of the signal set at “INPUT SIGNAL” is OFF. |
| ● | The present input value of the signal set at “INPUT SIGNAL” is ON. |

“STATUS” can be displayed in the condition file of any function.
To display “STATUS”, set “SIGNAL” for “FILE VALID COND”.

4. OUTPUT SIGNAL

Specify a signal to output the object condition file monitoring result.

To avoid a redundant output result, two of the same output signal cannot be specified in one system. The already-specified signal does not appear in the selection list in the same condition file.

Regarding the safety fieldbus output signals and the functional safety output signals, only the ones allocated as usable in the safety circuit board appear in the selection list.

| Value | Description |
|----------------------|--|
| NO CONFIG | Signal is not specified |
| FSBOUT01 to FSBOUT16 | Specify the functional safety general-purpose output signal. The number of the signal points differs depending on the safety I/O board to be connected. When the ASF02 board is connected, the signals 1 to 8 are used, and when the ASU03 unit is connected, the signals 1 to 16 are used. (# n): terminal number of the safety circuit board |
| SFBOUT01 to SFBOUT64 | Specify the safety fieldbus output signal. (signal 1 to 64) |
| FS-OUT01 to FS-OUT64 | Specify the functional safety output signal to the safety logic circuit. (signal 1 to 64) |

“OUTPUT SIGNAL” can be specified in the condition file of any function.

5 Safety Signal
 5.4 File Switching to Valid/Invalid by the Safety Input Signal

5.4 File Switching to Valid/Invalid by the Safety Input Signal

Judging method for switching the condition file using the safety input signal is explained here.

Fig. 5-1: Signal Setting Window

| INPUT SIGNAL | | SET | STATUS |
|---------------|--------------|------|--------|
| bit0 | FSBIN01(#1) | OFF | ● |
| bit1 | FSBIN02(#1) | ON | ● |
| bit2 | SFBIN01 | ON | ○ |
| bit3 | MS-OUT01 | OFF | ○ |
| bit4 | ----- | **** | ○ |
| OUTPUT SIGNAL | FSBOUT01(#1) | | ○ |

The input signal is judged line-by-line.

As shown in fig. 5-1 “Signal Setting Window”, when performing a setting as marked with the red square, the condition of bit 0 line is defined as satisfied because “ON” is set to {SET} at the input signal {FSBIN01}, and ● (=ON)} is set to {STATUS}.

Up to 5 signals can be set to a condition file (up to 4 for the tool change monitor function and the tool number select function).

Conditions of the lines from bit0 line to bit4 line are judged by the safety input signal respectively, the object condition file is validated only when all the conditions are satisfied.

For the line “****” (undefined) is indicated at {SET} is disregarded for this judgement.

Fig. 5-2: When the Conditions for File Validation is Satisfied

| INPUT SIGNAL | | SET | STATUS |
|---------------|--------------|------|--------|
| bit0 | FSBIN01(#1) | ON | ● |
| bit1 | FSBIN02(#1) | ON | ● |
| bit2 | SFBIN01 | OFF | ○ |
| bit3 | MS-OUT01 | OFF | ○ |
| bit4 | ----- | **** | ○ |
| OUTPUT SIGNAL | FSBOUT01(#1) | | ○ |

Annotations: Red boxes highlight the bit0-3 rows. A box labeled "All conditions satisfied" points to the status column of bit0-3. A box labeled "Ignored" points to the bit4 row.

Fig. 5-3: When the Condition for File Validation is Not Satisfied

| INPUT SIGNAL | | SET | STATUS |
|---------------|--------------|------|--------|
| bit0 | FSBIN01(#1) | ON | ● |
| bit1 | FSBIN02(#1) | ON | ● |
| bit2 | SFBIN01 | ON | ○ |
| bit3 | MS-OUT01 | OFF | ○ |
| bit4 | ----- | **** | ○ |
| OUTPUT SIGNAL | FSBOUT01(#1) | | ○ |

Annotations: Red boxes highlight the bit2-3 rows. A box labeled "Condition not satisfied" points to the status column of bit2-3. A box labeled "Ignored" points to the bit4 row.

5 Safety Signal
 5.4 File Switching to Valid/Invalid by the Safety Input Signal

There can be a time difference after the first signal and before the last signal. In the functional safety function, an interval of 32 [ms] is equipped to the system to be totally switched to internally settled after the last signal change.



For this reason, please take this into consideration when performing the following operations.

- When switching several signals, do not take more than 32 [ms].
 →The signals may be settled with half-specified values.
- Do not use signals that continue shifting ON/OFF within the interval of less than 32 [ms].
 →Signals will not be settled.

On the basis of above mentioned judging methods, following patterns can be conceived when switching files using three signals.

Pattern 1: When switching one file using one signal

Operate more than two files respectively.

Simultaneous monitoring is available.

The number of the object file: 3

| Condition file | Signal and setting | Setting | Conditions for validating the file |
|----------------|--------------------|---------|------------------------------------|
| File 1 | Signal A | ON | ●(Signal A) |
| File 2 | Signal B | OFF | ○(Signal B) |
| File 3 | Signal C | ON | ●(Signal C) |

5 Safety Signal

5.4 File Switching to Valid/Invalid by the Safety Input Signal

Pattern 2: When switching one file using more than two signals

Select one file out of several files.

Many files can be managed with less signals. This pattern is effective when simultaneous monitoring is not necessary.

The number of the object file: 8

| Condition file | Signal and setting | Setting | Conditions for validating the file |
|----------------|--------------------|---------|---|
| File 1 | Signal A | OFF | <input type="radio"/> (Signal A) |
| | Signal B | OFF | <input type="radio"/> (Signal B) |
| | Signal C | OFF | <input type="radio"/> (Signal C) |
| File 2 | Signal A | ON | <input checked="" type="radio"/> (Signal A) |
| | Signal B | OFF | <input type="radio"/> (Signal B) |
| | Signal C | OFF | <input type="radio"/> (Signal C) |
| File 3 | Signal A | OFF | <input type="radio"/> (Signal A) |
| | Signal B | ON | <input checked="" type="radio"/> (Signal B) |
| | Signal C | OFF | <input type="radio"/> (Signal C) |
| File4 | Signal A | ON | <input checked="" type="radio"/> (Signal A) |
| | Signal B | ON | <input checked="" type="radio"/> (Signal B) |
| | Signal C | OFF | <input type="radio"/> (Signal C) |
| File 5 | Signal A | OFF | <input type="radio"/> (Signal A) |
| | Signal B | OFF | <input type="radio"/> (Signal B) |
| | Signal C | ON | <input checked="" type="radio"/> (Signal C) |
| File 6 | Signal A | ON | <input checked="" type="radio"/> (Signal A) |
| | Signal B | OFF | <input type="radio"/> (Signal B) |
| | Signal C | ON | <input checked="" type="radio"/> (Signal C) |
| File 7 | Signal A | OFF | <input type="radio"/> (Signal A) |
| | Signal B | ON | <input checked="" type="radio"/> (Signal B) |
| | Signal C | ON | <input checked="" type="radio"/> (Signal C) |
| File 8 | Signal A | ON | <input checked="" type="radio"/> (Signal A) |
| | Signal B | ON | <input checked="" type="radio"/> (Signal B) |
| | Signal C | ON | <input checked="" type="radio"/> (Signal C) |

| | |
|-----|----------------------------|
| 5 | Safety Signal |
| 5.5 | Safety Signal Output Value |

5.5 Safety Signal Output Value

The output signal outputs the status of safety or not safety over the monitoring conditions when the object condition file is validated.

Followings show the meanings of output result for each safety function.

Basically, output signal ON is defined as safety side and OFF is defined as not safety side in preparation for the disconnection of the hard signals, etc.

In case the status becomes not safety and OFF is output during the monitoring, the OFF signal is kept outputting unless the error alarm is re-set.

If the alarm is set to be out of occurring by a condition file, the signal keeps outputting OFF while in not safety status and becomes ON when it returns to the safety status.



CAUTION

In case a major alarm occurred in the functional safety function, all the output signals are turned OFF.

• Axis range limit function

| Object file status | Monitoring result | Output value |
|--------------------|--|--------------|
| Invalid | - | OFF |
| Valid | All the axes monitoring is validated are inside the safety range. | ON |
| | Some of the axes monitoring are validated are detected to be outside the safety range | OFF |
| | For some of the axes monitoring are validated, the stop position to which coasting value is included are detected to be in error status when moving close to the border of the safety range. | OFF |

• Axis speed monitor function

| Object file status | Monitoring result | Output value |
|--------------------|---|--------------|
| Invalid | - | OFF |
| Valid | All the axes monitoring is validated are inside the safety range. | ON |
| | Some of the axes monitoring are validated are detected to be outside the safety range | OFF |

5 Safety Signal

5.5 Safety Signal Output Value

• Robot range limit function

| Object file status | Monitoring result | Output value |
|--------------------|---|--------------|
| Invalid | - | OFF |
| Valid | Object manipulator or tool is inside the safety range. | ON |
| | Object manipulator or tool is detected to be outside the safety range | OFF |
| | For the object manipulator or tool, the stop position to which coasting value is included are detected to be in error status when moving close to the border of the safety. | OFF |

• Speed limit function

| Object file status | Monitoring result | Output value |
|--------------------|--|--------------|
| Invalid | - | OFF |
| Valid | Object groups for monitoring are inside the limited speed. | ON |
| | Object groups for monitoring detected the limited speed error. | OFF |

• Tool angle monitor function

| Object file status | Monitoring result | Output value |
|--------------------|--|--------------|
| Invalid | - | OFF |
| Valid | The tool angle of the object group for monitoring is inside the limited angle. | ON |
| | An error is detected to the tool angle of the object group for monitoring. | OFF |

• Tool change monitor function

| Object file status | Monitoring result | Output value |
|--------------------|---|-------------------------------|
| Invalid | There is no valid file | OFF |
| Valid | One condition file is specified as valid and the value is inconsistent with the master CPU. | ON |
| | One condition file is specified as valid but the value is not consistent with the master CPU. | OFF the valid file signal |
| | Several condition files are specified as valid | OFF all the valid file signal |

• Tool number select function

| Object file status | Monitoring result | Output value |
|--------------------|---|-------------------------------|
| Invalid | There is no valid file. | OFF |
| Valid | One condition file is specified as valid. | ON |
| | Several condition files are specified as valid. | OFF all the valid file signal |

6 Common Settings

6.1 Function Disable Mode Setting

When the function disable mode (temporary disablement) is used, all the object condition files of the safety monitoring function (32 files) can be set invalid.

This mode is used in the following functions marked with ○.

| Function | Availability |
|------------------------------|--------------|
| Axis range limit function | ○ |
| Axis speed monitor function | X |
| Robot range limit function | ○ |
| Speed limit function | X |
| Tool angle monitor function | ○ |
| Tool change monitor function | ○ |
| Tool number select function | ○ |

Use this mode mainly to recover from the status when an out-of-range alarm of the range limit function occurred.

Although the alarm activated by the safety monitoring is a re-settable alarm, the same alarm occurs again if the manipulator or the external axis is located outside of the safety range.

Follow the procedures below when recovering from the alarm.

1. Temporarily disable the safety function which is detecting the alarm.
2. Reset the alarm.
3. Jog operate to move the manipulator or the external axis inside the safety range.
4. Release the function disable mode.

The function disable mode can be specified on the status list window. The AXIS RANGE LIMIT window is used as an example below.

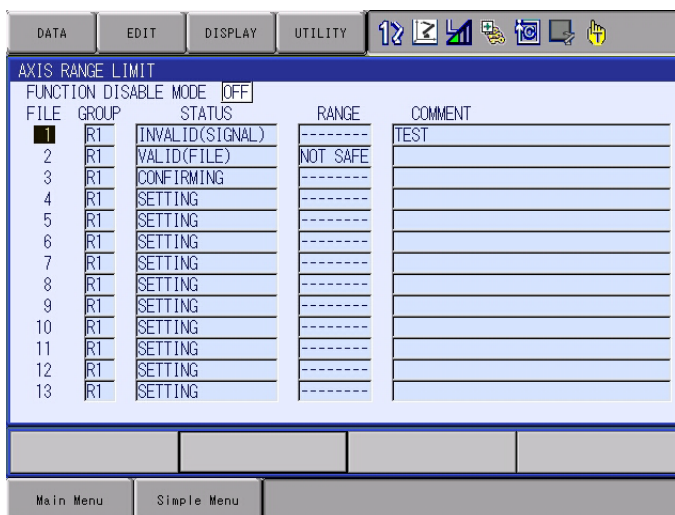

6 Common Settings

6.1 Function Disable Mode Setting

Set "ON" for "FUNCTION DISABLE MODE". The window changes as shown below to indicate that the function is temporarily disabled.



Also, in the message area at the lower right of the window, a message showing that the object function is being temporarily disabled appears.

<Message>

"Axis range limit function is temporarily disable"

"Robot range limit function is temporarily disable"

"Tool angle monitor function is temporarily disable"

"Tool change monitor function / Tool number select function is temporarily disable"

To an specific output signal, a signal for the disabled function is output.

<Specific output signal>

-Axis range limit is temporarily disabled

-Robot range limit is temporarily disabled

-Tool angle monitor is temporarily disabled

-Tool change monitor / Tool number select is temporarily disabled

6 Common Settings
6.1 Function Disable Mode Setting

6.1.1 Restrictions While Function Disable Mode Is Enabled

Restrictions are set to the following operations while the function disable mode is enabled because this mode also disables monitoring operations.

When moving the manipulator or the external axis while the restrictions are set, only the jog operation using the programming pendant is available. And an error occurs when one of the following operations is executed.

- Play back operation
- Forward and Backward operations
- Test-run operation
- I/O Jog operation
- Execution of motor gun auto tuning

<Error Message>

Error 1191: Axis range limit function is temporarily disable

Error 1192: Robot range limit function is temporarily disable

Error 1193: Tool angle monitor function is temporarily disable

Error 1194: Tool change monitor function / Tool number select function is temporarily disable

Following error codes are returned when executing the data transmission or start commands of the high-speed Ethernet server, or when executing jobs of MotoPlus or Pendant customization functions.

<Error Message>

3061: "Axis range limit function is temporarily disable"

3062: "Robot range limit function is temporarily disable"

3063: "Tool angle monitor function is temporarily disable"

3064: "Tool change monitor function / Tool number select function is temporarily disable"

6 Common Settings
 6.1 Function Disable Mode Setting

6.1.2 Security Level Setting for Function Disable Mode

For the functions in which the function disable mode exists, the security level to use this mode can be selected.

Follow the procedures below to open the settings window of the function disable mode.

1. Set the security mode to the safety mode, and then select {SETUP} under the main menu.

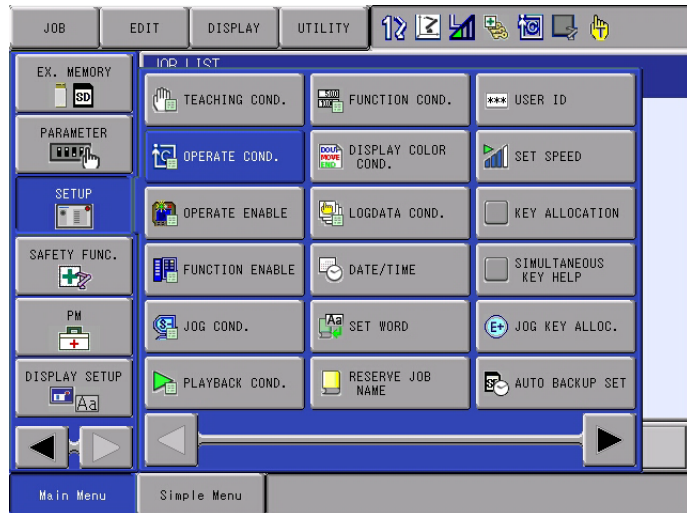

2. Select {OPERATE COND.} in the sub menu.
 - The OPERATE CONDITION SETTING window appears.
 - When the security mode is higher than the safety mode and the functional safety function is enabled, “FUNC DISABLE MODE SECURITY(FSU)” appears on this window.

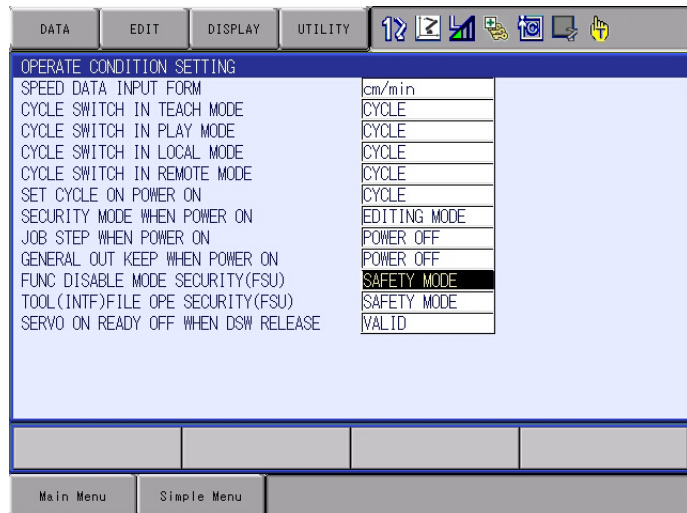

<Details of the Window>

FUNC DISABLE MODE SECURITY (FSU)

| Value | Description |
|-----------------|---|
| EDITING MODE | Switching of FUNCTION DISABLE MODE is permitted in the editing mode or higher. |
| MANAGEMENT MODE | Switching of FUNCTION DISABLE MODE is permitted in the management mode or higher. |
| SAFETY MODE | Switching of FUNCTION DISABLE MODE is permitted in the safety mode. (Default) |

| | |
|-----|--------------------------------------|
| 6 | Common Settings |
| 6.2 | External Axis Coasting Value Setting |

6.2 External Axis Coasting Value Setting

This setting can be referred by the following safety functions. When using the safety function marked with ○ in the following table, an advanced setting is required.

| Function | Reference |
|------------------------------|-----------|
| Axis range limit function | ○ |
| Axis speed monitor function | X |
| Robot range limit function | ○ |
| Speed limit function | X |
| Tool angle monitor function | X |
| Tool change monitor function | X |
| Tool number select function | X |

In case the power supply to the servo is turned OFF while the manipulator is in operation, it may move a little bit before completely stops because of the force of inertia. The functional safety function functions by estimating the moving value (coasting value) of the manipulator from the servo OFF position to the completely stopped position in accordance with each axis speed.

By setting the manipulator to stop just before it exceeds the safety range including its coasting distance on the basis of the estimated coasting value, the stop position of the manipulator does not exceed the safety range.

For example, when the manipulator is operating with 100% of operating speed, the functional safety function starts instructing the manipulator to stop “the coasting value when the manipulator is operating with 100% of operating speed” before the border of its limited area.

Also, when the manipulator is operating with 50% of operating speed, the functional safety function starts instructing the manipulator to stop “the coasting value when the manipulator is operating with 50% of operating speed” before the border of its limited area.

For the coasting value of the manipulator, it is already set before shipment. However, for that of an external axis, it should be set by the customer.

When the monitoring operations in the axis range limit function or the robot range limit function is valid but its coasting value is not set, an error may occur and following operations will be restricted.

- Play back operation
- Forward and Backward operations
- Test-run operation
- I/O Jog operation
- Execution of motor gun at tuning

NOTE

The coasting value is difficult to obtain by calculation. Do not use values using in other systems because the value varies largely depending on the structure or shape of the external axis.

When inputting a temporary value, set a large value enough to avoid the risk.

6 Common Settings

6.2 External Axis Coasting Value Setting

<Error message>

“Error 0384: Coasting value setting of Ex-axis is not completed”

Following error code is returned when executing the data transmission, the starting system command by the high-speed Ethernet server or the play back operations from the programming pendant customization function or MotoPlus before setting of the coasting value is not completed.

<Error codes>

3065 “Coasting value setting of Ex-axis is not completed”



Setting of the coasting value is not necessary for the system to which the external axis does not exist. Also, following sub menu is not displayed.

Open the external axis coasting value setting window by the following procedures.

1. Set the security mode to the safety mode, and then select {SAFETY FUNC.} under the main menu.

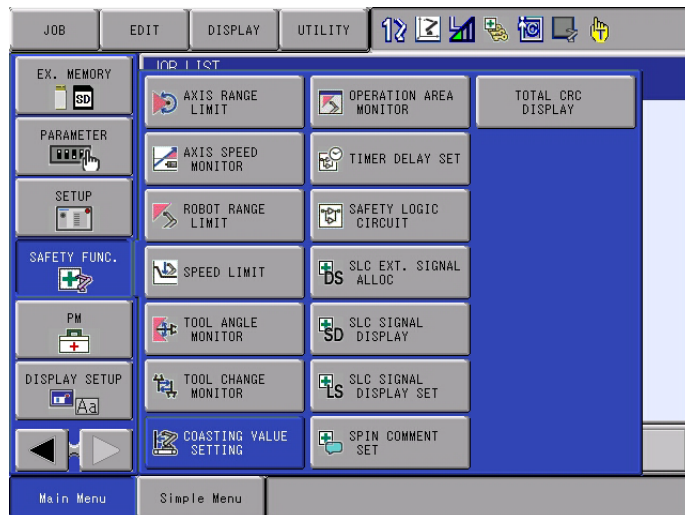

2. Select {COASTING VALUE SETTING} in the sub menu.
 - The COASTING VALUE SETTING window appears.
 - When several external axes exist, press [PAGE] to alternate the external axes.

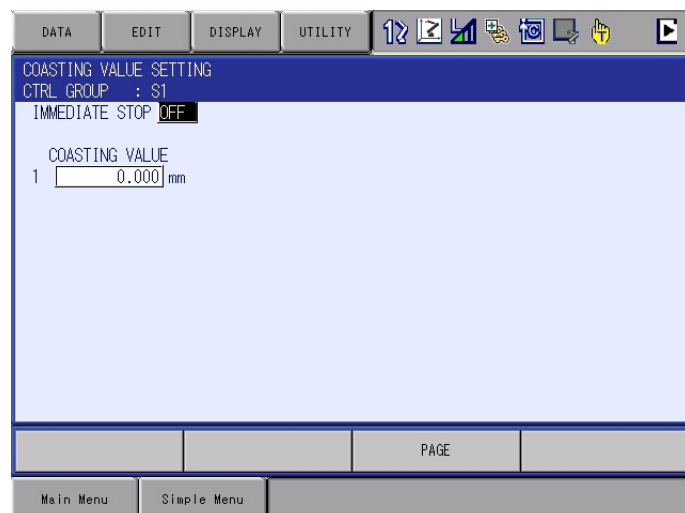

6 Common Settings
6.2 External Axis Coasting Value Setting

<Details of the Window>

1. IMMEDIATE STOP

The value input to “COASTING VALUE” must be measured in the category 0 status. For the coasting value measurement, the category can be modified.

| Value | Description |
|-------|---|
| OFF | Category 1 is set for the stop of the robot and the external axis (Default) |
| ON | Category 0 is set for the stop of the robot and the external axis |

NOTE

- “OFF” should be set to “IMMEDIATE STOP” again after the coasting value measurement.
- When the starting operation is executed while “ON” is set, a dialog box notifying that “Immediate stop” is already set appears.
If performing the coasting value measurement, the play back operation can be executed after selecting “YES” and re-start the starting operation.

Immediate stop is valid. Operate?

YES

NO

2. COASTING VALUE

Set the coasting value to a object axis. The inputting range is from 0.000 to 999.999.

NOTE

A message “Select ‘Safety Board FLSH Reset’ in the maintenance mode.” appears when the coasting value is edited.
Re-set the data by following the procedures in *chapter 7.2 “FLASH Data Reset”*.



While modifying the coasting value, the power supply to the servo is stopped and the operation of the manipulator or the axis is disabled. However the modification is continuously available. For this reason, it is recommended to turn ON the power supply to the controller after completing the modification of all the coasting value.

6.3 Tool File Setting

This setting can be referred by the following safety functions. When using the safety function marked with ○ in the following table, an advanced setting is required.

| Function | Reference |
|------------------------------|-----------|
| Axis range limit function | X |
| Axis speed monitor function | X |
| Robot range limit function | ○ |
| Speed limit function | ○ |
| Tool angle monitor function | ○ |
| Tool change monitor function | X |
| Tool number select function | X |

The tool file must be appropriately specified for the precise monitoring of the safety function.

Make sure to perform the tool file setting properly by referring to “YRC1000 INSTRUCTIONS (RE-CTO-A221) 8.3 Tool Data Setting”.

6 Common Settings
6.4 Tool Interference File Setting

6.4 Tool Interference File Setting

This setting can be referred by the following safety functions. When using the safety function marked with ○ in the following table, an advanced setting is required.

| Function | Reference |
|------------------------------|-----------|
| Axis range limit function | X |
| Axis speed monitor function | X |
| Robot range limit function | ○ |
| Speed limit function | X |
| Tool angle monitor function | X |
| Tool change monitor function | X |
| Tool number select function | X |

In the robot range limit function, monitoring of the manipulator as well as its tool is executed. In this case, register the tool shape to the tool interference file as an approximate model.

Set a tool interference file as instructed below.

1. Set the security mode to the safety mode, and then select {ROBOT} under the main menu.

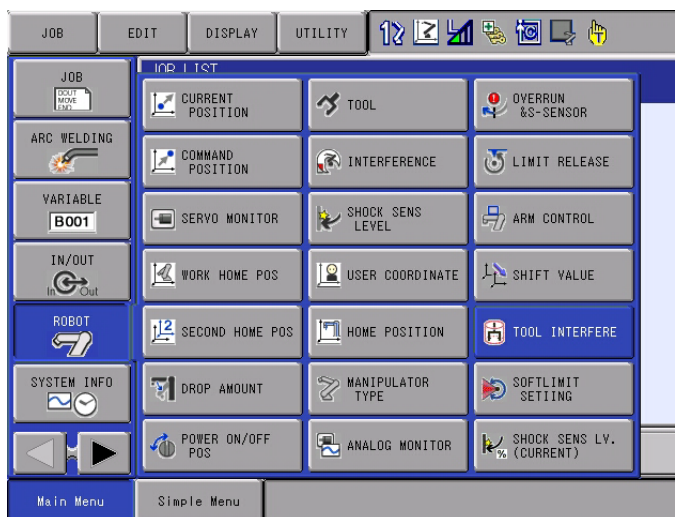

6 Common Settings

6.4 Tool Interference File Setting

2. Select {TOOL INTERFERE} under the sub menu.
 - The TOOL INTERFERE window appears.

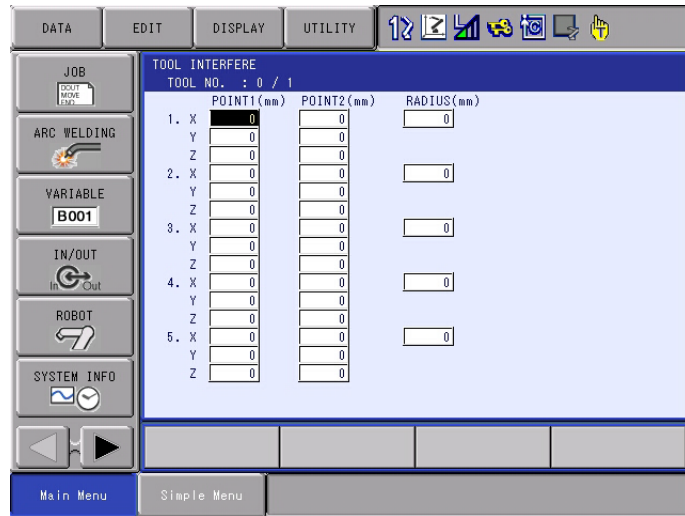

6 Common Settings
6.4 Tool Interference File Setting

<Details of the Window>

1. 1 to 5

Cylinders and spheres for up to 5 positions can be set.

2. POINT1 to POINT5

Input the coordinate value of XYZ, and set both ends of a cylinder.
The distance from the center of T axis flange should be set like tool dimension setting.

3. RADIUS

The radius of the spheres and cylinder between POINT 1 and POINT 2 is set. The spheres are set to POINT 1 and POINT 2.

It is measured in [mm]

The specified radius must have a margin of at least 10 mm compared with the actual tool.

<Tool interference file setting example>

Fig. 6-1: Tool Interference File Setting Example

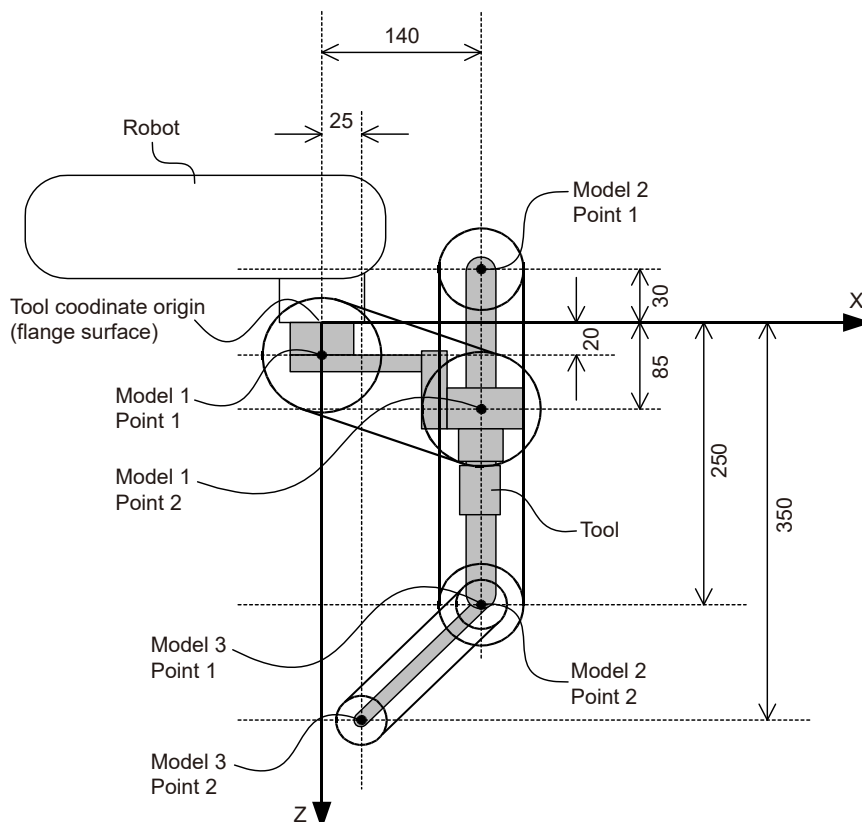

6 Common Settings
 6.4 Tool Interference File Setting

Model 1: Set the flange surface to Point 1, and (X=140, Z=85) to Point 2.

Model 2: Set (X=140, Z=-30) to Point 1, and (X=140, Z=250) to Point 2.
 This setting defines a model that is parallel to the Z direction of the tool coordinates.

Model 3: Set (X=140, Z=250) to Point 1, and (X=25, Z=350) to Point 2.
 By setting the point 2 of model 2 and the point 1 of model 3 at the same position, model 2 and 3 are defined at consecutive positions.

Following window shows the result of the setting model shown in fig. 6-1 "Tool Interference File Setting Example".

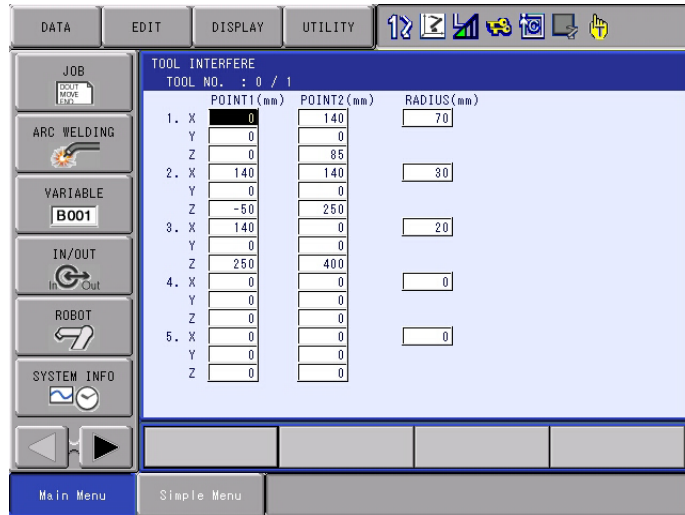

CAUTION

When setting a radius to a tool model, set a little larger radius corresponding to the distance from the flange surface as shown below.

| Distance from the flange surface | Recommended radius |
|----------------------------------|--------------------|
| 0 mm | 55 mm |
| 100 mm | 58 mm |
| 200 mm | 60 mm |

6 Common Settings

6.5 Security Level Setting for Tool File and Tool Interference Files

6.5 Security Level Setting for Tool File and Tool Interference Files

In the system where the functional safety function is not used, both tool file and tool interference files can be operated in the editing or higher mode.

On the other hand, in the system where the function is used, in the default setting, they can be operated only in the safety mode because these files influence the safety monitoring operation.

The person who has a safety license can select one out of three security level for operating the tool file or tool interference file.

The setting window opens by the following procedures.

1. Set the security mode to the safety mode, and then select {SETUP} under the main menu.

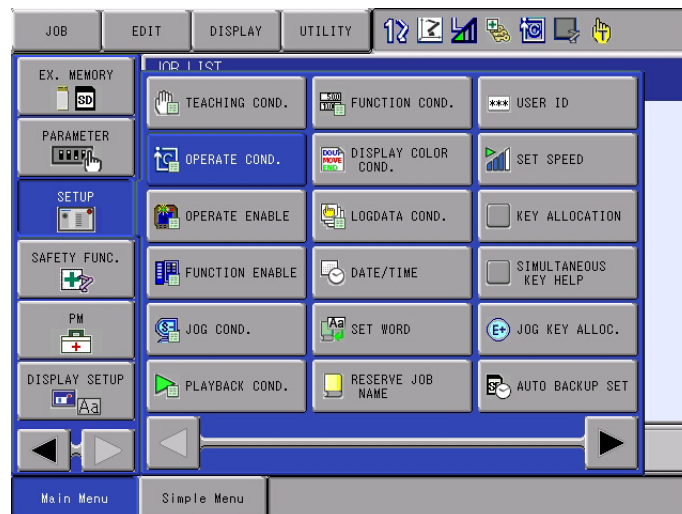

2. Select {OPERATE COND.} under the sub menu.
 - The OPERATE CONDITION SETTING window appears.
 - When the security level is higher than the safety mode and the functional safety function is enabled, “TOOL (INTF)FILE OPE SECURITY(FSU)” appears on this window

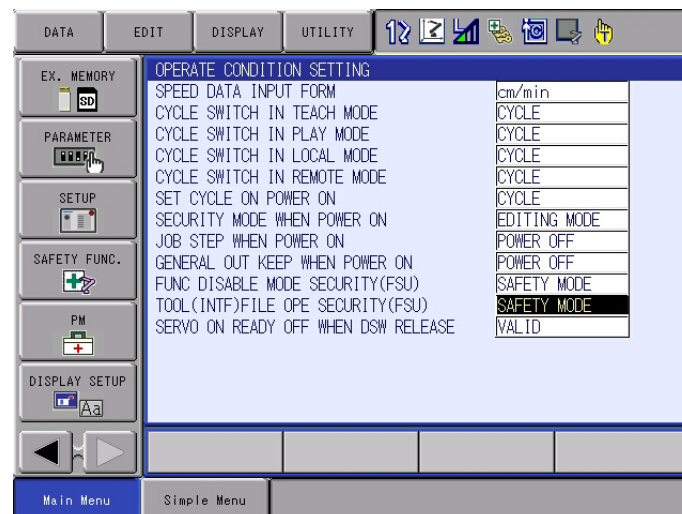

-
- 6 Common Settings
 - 6.5 Security Level Setting for Tool File and Tool Interference Files
-

<Details of the Window>

TOOL (INTF)FILE OPE SECURITY(FSU)

| Value | Description |
|-----------------|--|
| EDITING MODE | Operation of the tool file and tool interference file is permitted in the editing mode or higher. |
| MANAGEMENT MODE | Operation of the tool file and tool interference file is permitted in the management mode or higher. |
| SAFETY MODE | Operation of the tool file and tool interference file is permitted in the safety mode. (Default) |

| | |
|-----|---|
| 6 | Common Settings |
| 6.6 | Using the PMT Function Together with the Functional Safety Function |

6.6 Using the PMT Function Together with the Functional Safety Function

6.6.1 How to Use the PMT Function Together with the Functional Safety Function

For system version YAS2.80.00A(*)-00 or later, the tool file that was last saved on the safety board is stored inside the system separately from the tool file (TOOL.CND) that is used normally.

The tool file to verify against the tool file that was saved on the safety board can be specified with the following parameter.

If S2C450 is set to 1, the PMT function can be used with the functional safety function. The setting of this parameter can be changed only if the security mode is safety mode. For this reason, the setting must be performed by the person who has a safety license.

| Parameter No. | Details | Default Value |
|---------------|--|---------------|
| S2C450 | Specify the target for verifying the tool file to use in the safety functions. 0: Verify the tool file to use normally against the tool file that was saved on the safety board (the PMT function will not be used together with the functional safety function). 1: Verify the tool file that was last saved on the safety board against the tool file that was saved on the safety board (the PMT function will be used together with the functional safety function). | 0 |



WARNING

When the tool file is changed with the SETTOOL instruction, only the TCP to control the robot path is changed. The TCP to monitor with the safety function is not changed. Therefore, the robot will operate in a state where the TCPs do not match.

For the safety functions that use the tool file, refer to *chapter 6.3 "Tool File Setting"*.

When changing the parameter for this function, first conduct a sufficient risk assessment and carefully check the impact on the safety functions.

If S2C450 is set to 0, "Alarm 0300: VERIFY ERROR (SYSTEM CONFIG-DATA) [10]" may occur when the control power is turned ON. For details, refer to *chapter 6.6.3 "Tool File Verification Check in a System Using the PMT Function Together with the Functional Safety Function"*.

6 Common Settings

6.6 Using the PMT Function Together with the Functional Safety Function

Since this parameter is related to the safety function, if the parameter S2C450 is edited in management mode, the following error message will appear.

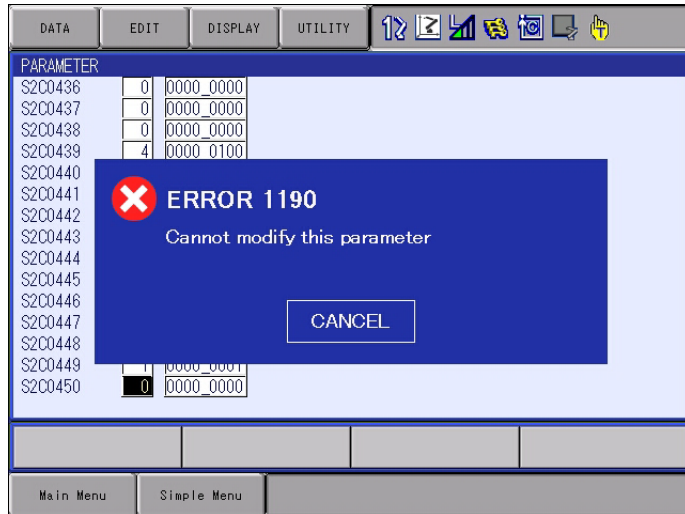

If a parameter file is loaded in management mode, the parameter S2C450 will be checked to see if it has changed before/after loading.

If the parameter has changed, the following error message will appear, and the parameter file will not be loaded.

A parameter file in which the parameter S2C450 has been changed must be loaded in safety mode.

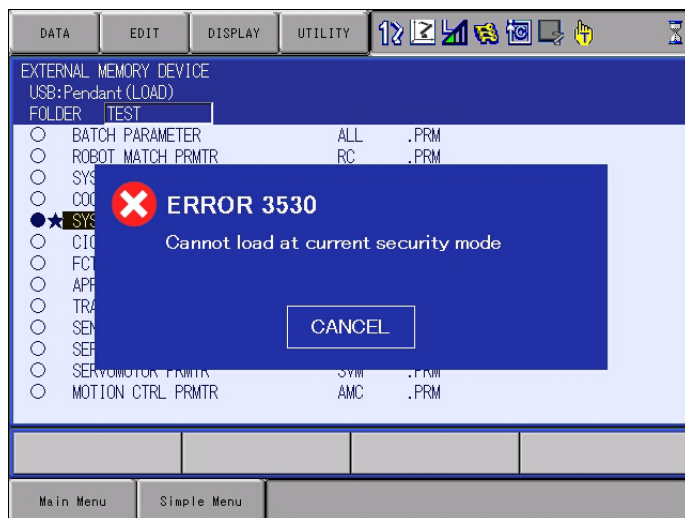

6 Common Settings

6.6 Using the PMT Function Together with the Functional Safety Function

The tool file that was saved on the safety board stored inside the system can be confirmed in the tool window.

Press {DISPLAY}, and then select {MONITORING COND.}.

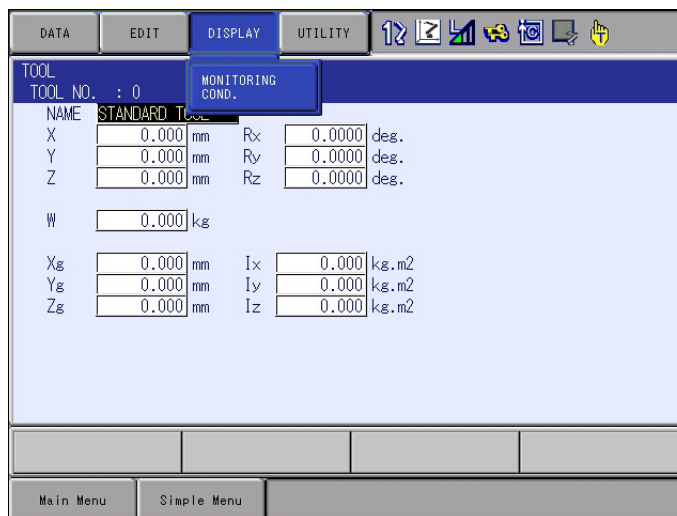

The window is changed to the “MONITORING COND.” window to indicate the details of the tool file that was last saved on the safety board.

The tool file cannot be edited in this window. The value of the tool file displayed in this window will be updated when the tool file is saved on the safety board with the readback operation by the person who has a safety license.

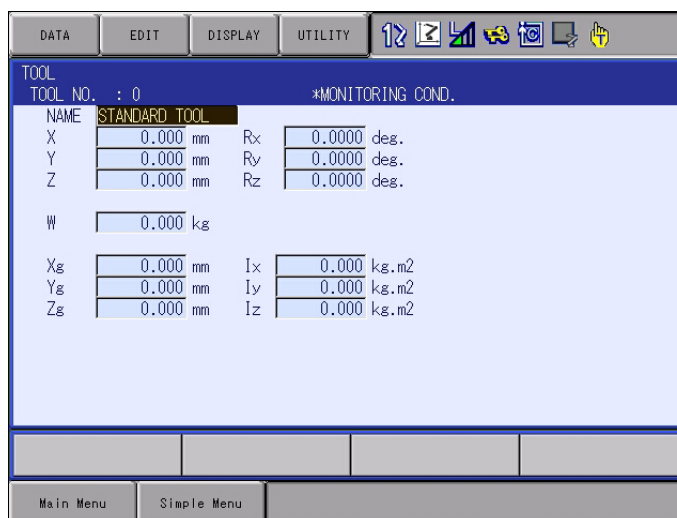

6 Common Settings
 6.6 Using the PMT Function Together with the Functional Safety Function

To show the current tool file or to edit the value of the tool file, press {DISPLAY}, and then select {TOOL FILE (CURRENT)}.



When verifying the current tool file against the tool file that was saved on the safety board, the comparison result of the following two tool files: the tool file that was last saved on the safety board and the tool file to use normally (TOOL.CND) is output to a concurrent I/O signal (specific output signal).

- 52585:
 The comparison result of two tool files is output. ON is for the mismatch, and OFF is for the match.

| Value | Details |
|-------|---|
| OFF | The tool file that was last saved on the safety board and the tool file to use normally match. |
| ON | The tool file that was last saved on the safety board and the tool file to use normally do not match. |

- 6 Common Settings
- 6.6 Using the PMT Function Together with the Functional Safety Function

6.6.2 Monitoring the Amount of Change in the Tool Files

For system version YAS2.80.00A(*)-00 or later, the amount of change in tool files is monitored by checking the difference between the tool file that was last saved on the safety board and the tool file that is set with the SETTOOL instruction.

The amount of change in the above two tool files is checked when the SETTOOL instruction is executed, and the following alarm will occur if the threshold is exceeded.

Alarm 4605: SETTOOL ERROR [2]



6 Common Settings
 6.6 Using the PMT Function Together with the Functional Safety Function

The threshold for the amount of change in tool files can be specified with the following parameter.
 The setting of this parameter can be changed only if the security mode is safety mode. For this reason, the setting must be performed by the person who has a safety license.

| Parameter No. | Details | Unit | Default Value |
|---------------|--|----------|---------------|
| S3C1193 | The maximum allowable deviation from the tool file that was last saved on the safety board when the tool data is automatically set (SETTOOL instruction is executed). 0: Do not monitor the amount of change in tool files. 1 or higher: Set the value of the parameter to the threshold and perform monitoring. | 0.001 mm | 20000 |

 **WARNING**

For system versions before YAS2.80.00A(*)-00, the default value of S3C1193 is 0. For this reason, the amount of change in the tool files will not be monitored simply by upgrading from a system version before YAS2.80.00A(*)-00 to system version YAS2.80.00A(*)-00 or later.

To monitor the amount of change in tool files, first upgrade the system version, and then conduct a sufficient risk assessment and set the value of S3C1193.

Since this parameter is related to the safety function, if the parameter S3C1193 is edited in management mode, the following error message will appear.

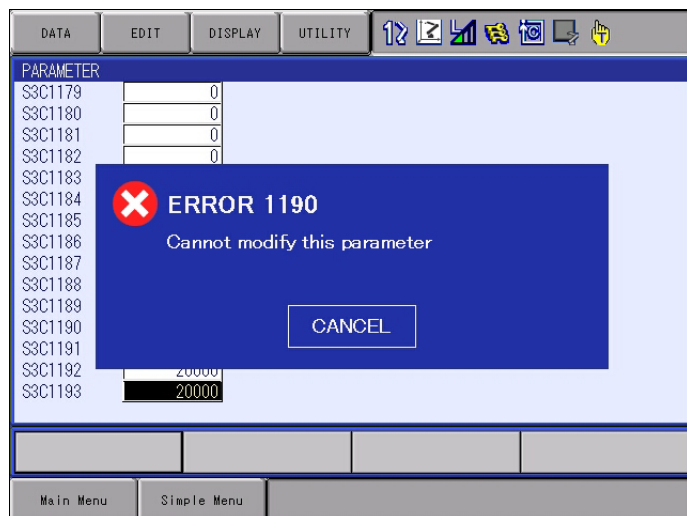

6 Common Settings

6.6 Using the PMT Function Together with the Functional Safety Function

If a parameter file is loaded in management mode, the parameter S3C1193 will be checked to see if it has changed before/after loading.

If the parameter has changed, the following error message will appear, and the parameter file will not be loaded.

A parameter file in which the parameter S3C1193 has been changed must be loaded in safety mode.

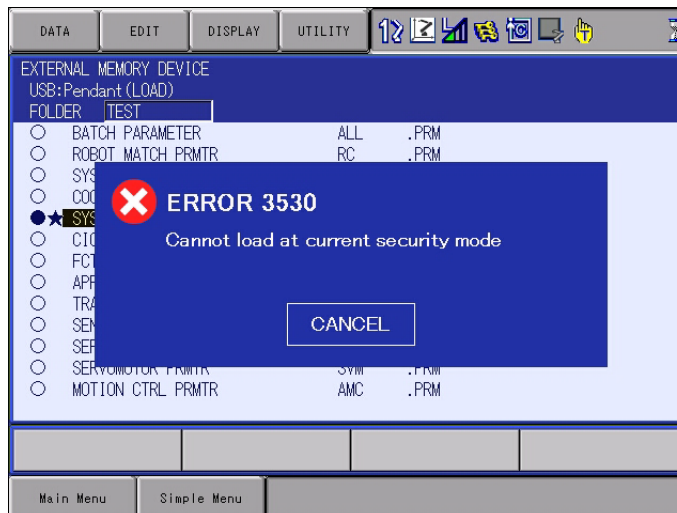

| | |
|-----|---|
| 6 | Common Settings |
| 6.6 | Using the PMT Function Together with the Functional Safety Function |

6.6.3 Tool File Verification Check in a System Using the PMT Function Together with the Functional Safety Function

When changing parameters and condition files, such as the tool file to be used in the safety functions (TOOL.CND), the following items must be checked by the person who has a safety license.

- Visually confirm that setting values are correct by using the readback operation.
- Perform an operation check using the newly set parameters and condition files and confirm that the safety functions work as intended.

The changed tool file is saved on the safety board by the above readback operation.

For a system that changes tool files using the PMT function, the tool file (TOOL.CND) is automatically changed by the PMT function. Changing the tool file with the PMT function is not accompanied with the above checks by the person who has a safety license, so the tool file on the safety board is not updated.

When the control power is turned ON, a verification check is performed on the tool file that was saved on the safety board and the tool file in the system, and if the files do not match, the following alarm occurs.

Alarm 0300: VERIFY ERROR (SYSTEM CONFIG-DATA) [10]

- 6 Common Settings
- 6.7 Disabling Functional Safety by Changing Connection Settings

6.7 Disabling Functional Safety by Changing Connection Settings

If functional safety must be disabled for some reason, such as a failure of the safety board, it can be disabled by changing the functional safety connection setting in maintenance mode.

Use the following procedure to disable functional safety.

1. Select {SYSTEM} under the main menu, and then select {SECURITY} to change the security mode to the safety mode.



2. Select {SYSTEM} under the main menu, and then select {SETUP} under the sub menu.
 - The SETUP window appears.

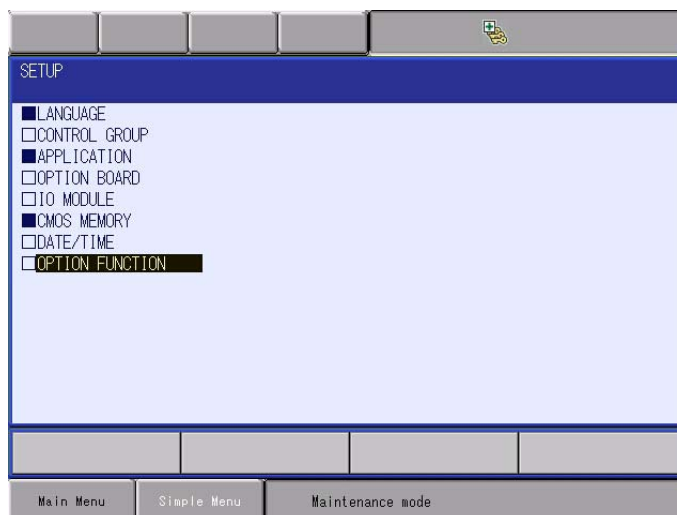

6 Common Settings

6.7 Disabling Functional Safety by Changing Connection Settings

3. Select "OPTION FUNCTION", "Functional safety" and "DETAIL".

– The Functional safety window appears.

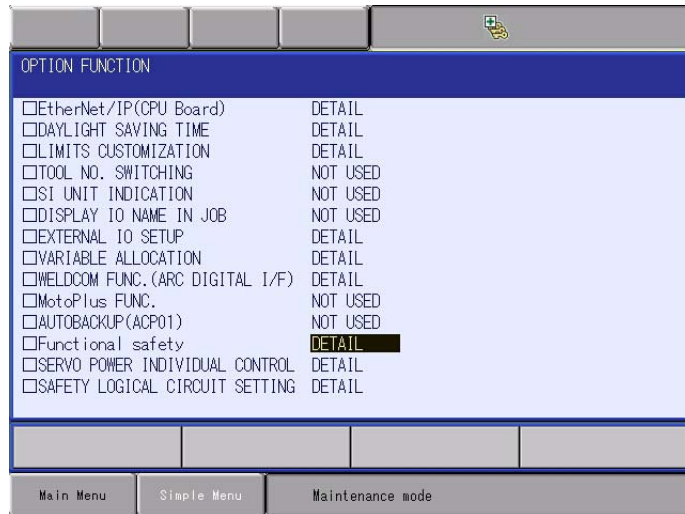

4. Select "Connection setting".

– The Connect setting window appears.

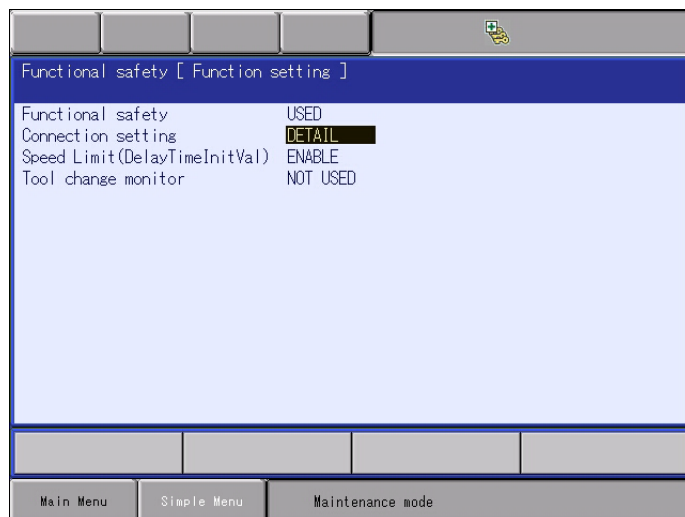

6 Common Settings

6.7 Disabling Functional Safety by Changing Connection Settings

5. Change to set “NOT USED” for the functional safety board to invalidate.

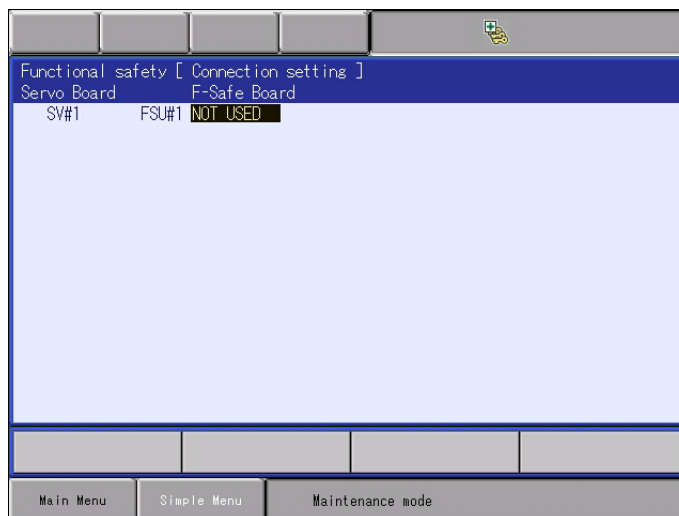

6. Press [ENTER] twice, and a dialog box asking “Modify?” appears.
– Select “YES”.

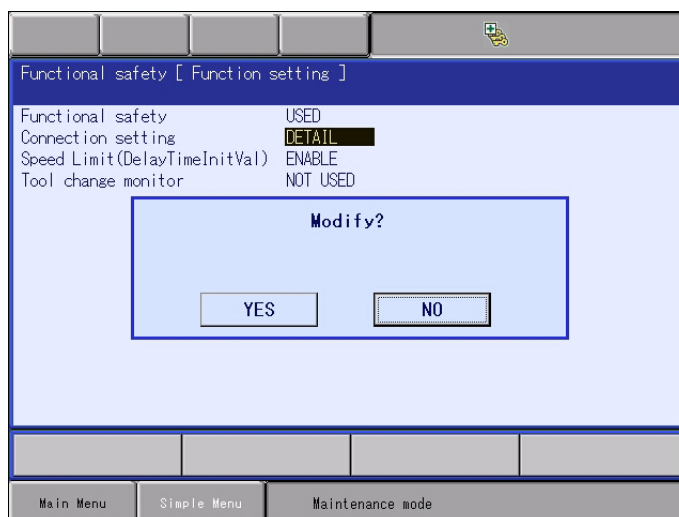

6 Common Settings

6.7 Disabling Functional Safety by Changing Connection Settings

- Select “YES”, and a dialog box asking “Initialize related files?” appears.
- If the setting related to functional safety has already specified, select “NO”. (When “YES” is selected, the setting related to functional safety will be initialized.)

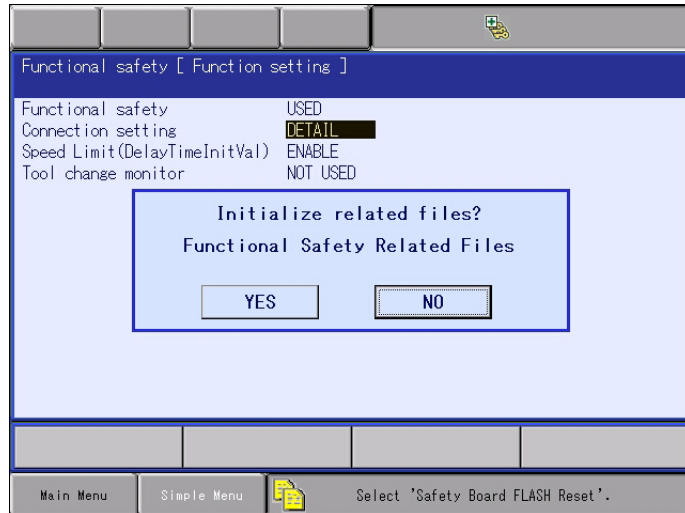

7. Select {FILE} under the main menu, and then select {INITIALIZE} under the sub menu.

- The INITIALIZE window appears.

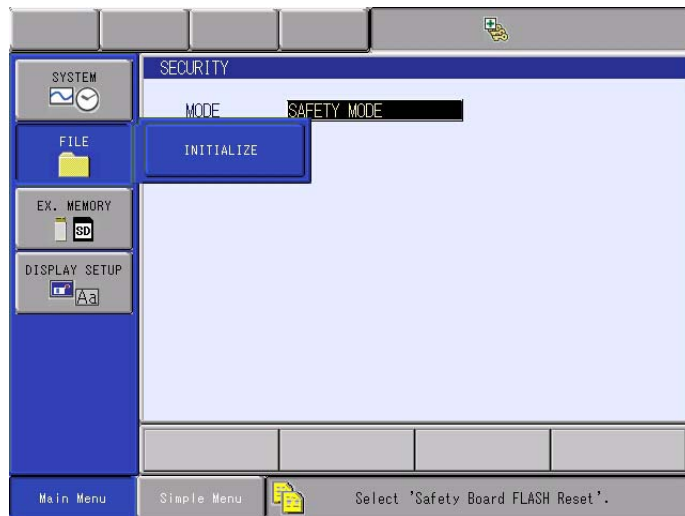

6 Common Settings

6.7 Disabling Functional Safety by Changing Connection Settings

8. Move the cursor and select “Safety Board FLASH Reset” on the window.

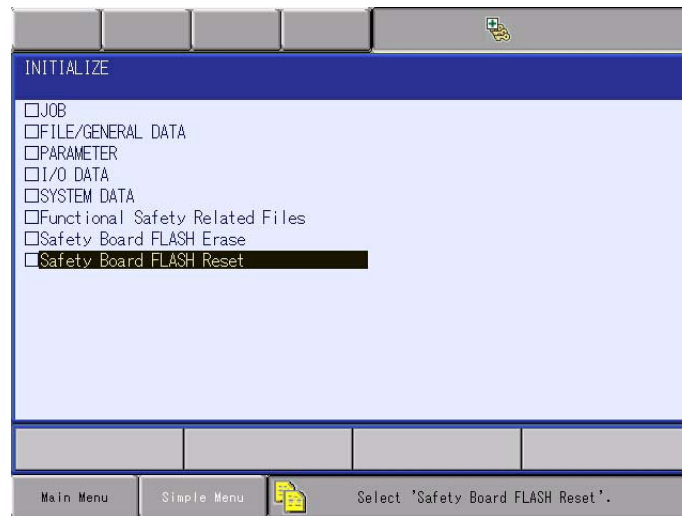

9. Select “YES” when a dialog box asking "Reset?" appears.
- Data of the safety circuit board is reset. A few seconds later, a beep will sound, indicating that the data of the safety circuit board has been reset.

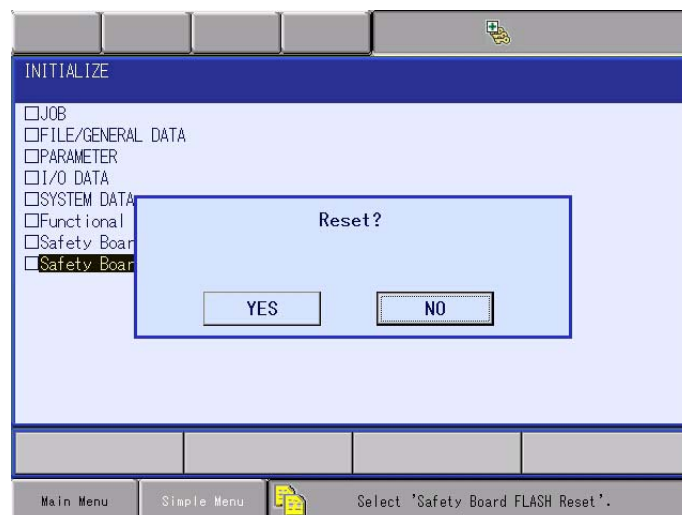

10. Turn ON the controller power supply.



When validating the functional safety again, perform setting in the same procedures as described in this chapter, and change the functional safety to validate to "USED" in step 5.

7 Data Protection

7.1 Saving Dual Data

The data related to the safety function is saved in the safety circuit board memory in a duplicated manner for safety.

When the control power is turned ON, check is performed to see that dual data sets are the same.

If they are different when the control power is turned ON, the following alarm occurs.

Alarm 0300: "VERIFY ERROR(SYSTEM CONFIG-DATA)[10]"

In the system with the functional safety function, a message "Select 'Safety Board FLASH Reset' in the maintenance mode" is displayed after the following operations.

Turning ON or OFF causes error in verification.

- The data related to the safety function is loaded from an external storage.
- A parameter related to the safety function is rewritten by setting operations in maintenance mode.
- The zeroing function is performed.
- Encoder is reset

In case one of the above mentioned operations is performed, re-set the data following the procedures shown in *chapter 7.2 "FLASH Data Reset"*.

In the maintenance mode, there are cases when parameters related to the safety function are rewritten by several setting operations.

For this reason, the message "Select 'Safety Board FLASH Reset'" may be displayed.

Perform the safety board FLASH reset operation by following the procedure shown in *chapter 7.2*.

7.2 FLASH Data Reset

If the following alarm occurs when the control power supply is turned ON,
Alarm 0300: "VERIFY ERROR(SYSTEM CONFIG-DATA)[10]"

perform the following operations to re-set the data of the function safety board.

1. When the controller power is turned ON,
Alarm 0300: "VERIFY ERROR(SYSTEM CONFIG-DATA)[10]" occurs and the maintenance mode is started up.
2. Select {SYSTEM} under the main menu, and then select {SECURITY} to change the security mode to the safety mode.



3. Select {FILE} under the main menu, and then select {INITIALIZE} under the sub menu.

– The INITIALIZE window appears.

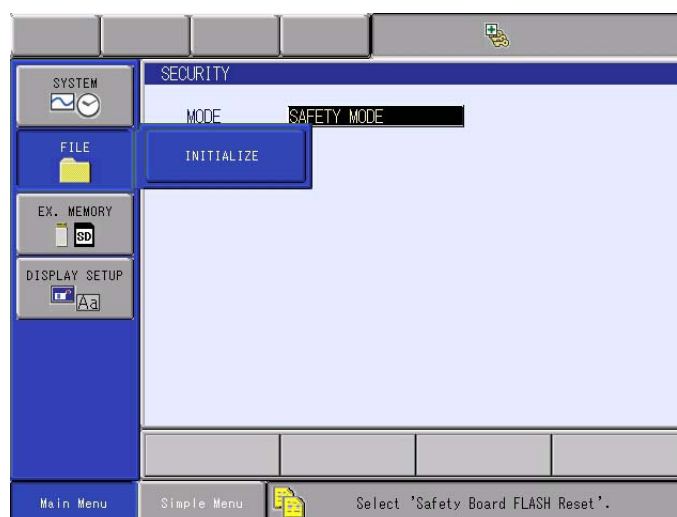

7 Data Protection

7.2 FLASH Data Reset

4. Move the cursor to “Safety Board FLASH Reset” and press [ENTER].

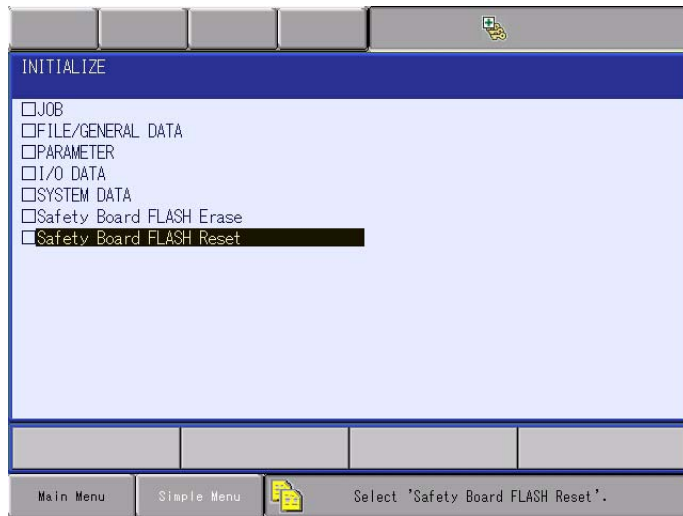

5. The dialog box “Reset?” is displayed. Select “YES”.

- The data of the safety circuit board is re-set. A few seconds later, a beep sounds and the data setting is completed.

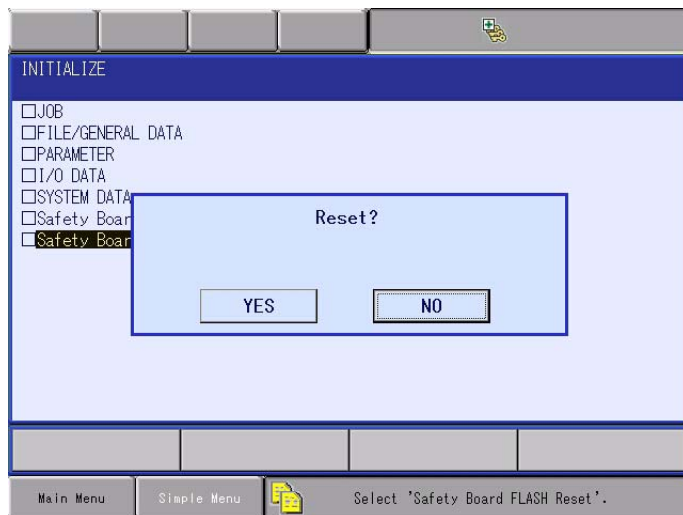

6. When the data reset is completed, turn the control power OFF and then turn the power ON again.

7 Data Protection
7.3 Change of Condition File by an External Device

7.3 Change of Condition File by an External Device

When using the functional safety function, the data used for the setting of safety monitoring must not be modified by an external device. Therefore, when loading the condition file from the external memory device, loading is allowed only when it is confirmed that the contents of the saved file have not been modified.

7.3.1 Outputting the CRC Value to the External Memory Device

When the file (shown in table 7-1) referred to for the functional safety is saved in the external memory device, the CRC value is added into the file. The CRC value, which is created based on the file data, is a fixed value unless the contents of the file are modified. When the CRC value created from the contents of the data which is read during file loading and the CRC value added into the file are different, an alarm 4796: "Functional Safety Data CRC Error" occurs and the file cannot be loaded.

Set the save data CRC check function (FSU) to invalid to load a file even if the CRC values are different. This function can also be set to valid or invalid per file in system software version YAS4.74.00A(□)-00 or later.

For the save data CRC check function (FSU), refer to *chapter 7.3.5 "Save Data CRC Check Function (FSU)"*.

(e.g.)Tool file

```
//TOOL 0
///CRC 4294967294 (CRC value)
///NAME standard tool
0.000, 0. 000, 0. 000, 0. 0000, 0.0000, 0. 0000
0.000, 0. 000, 0. 000
0.000.
0.000, 0. 000, 0. 000
0.000, 0, 1
```

Table 7-1: Files to which the CRC Value is output while Functional Safety is Valid

| File | File name of the external memory device |
|---|---|
| Tool file | TOOL.CND |
| Tool interference protection file | TOOLINTF.DAT |
| Home position calibration data | ABSO.DAT |
| Axis range limit data | AXRNGMT.DAT |
| Axis speed monitor data | AXSPDMON.DAT |
| Robot range limit data | RBRNGMT.DAT |
| Speed limit data | SPDLMT.DAT |
| Tool angle monitor data | TLANGMON.DAT |
| Tool change monitor data / Tool number select data | TLCHGMON.DAT |
| Functional definition parameter | FD.PRM |
| System definition parameter | SD.PRM |
| Servo parameter | SV.PRM |
| Servo motor parameter | SVM.PRM |
| Robot match parameter | RC.PRM |
| Coordinate origin parameter | RO.PRM |
| Motion function parameter | MF.PRM |
| Robot expand parameter | RE.PRM |
| Safety function parameter | FMS.PRM |
| System match parameter | SC.PRM |

7 Data Protection
 7.3 Change of Condition File by an External Device

NOTE Since the CRC value has not been added to the file saved in the system in which functional safety is invalid, the file cannot be loaded in the system in which functional safety is valid.

7.3.2 Confirming Method of the CRC Value

The CRC value of each data can be confirmed in the TOTAL CRC CONFIRM window. The TOTAL CRC CONFIRM window appears when selecting {SAFETY FUNC.} and then selecting {TOTAL CRC CONFIRM} under the main menu.

In this window the CRC value and the date of the last update of each data are shown.

CRC value: the CRC value calculated from the file data.

The same value is shown as the value which is output to the file when the file is saved in the external memory device. The file is usually updated simultaneously when modifying the data. However, when performing the modification in which the Functional Safety Board FLASH Reset is necessary, an asterisk appears, and then the value is shown after resetting the Functional Safety Board Flash.

Last update date: The last date and time when the file was modified (edited, loaded, or initialized) are shown.

In case that the data has not been modified since the system started operating, an asterisk is shown.

| TOTAL CRC CONFIRM | | |
|------------------------------|-------------|------------------|
| TOOL | | 0381761669 |
| | LAST UPDATE | 2017/06/01 15:56 |
| TOOL INTERFERE | | 4263051367 |
| | LAST UPDATE | 2017/06/01 15:56 |
| HOME POS CALIB | | 0726273504 |
| | LAST UPDATE | 2017/06/01 15:56 |
| AXIS RANGE LIMIT | | 1022308666 |
| | LAST UPDATE | 2017/06/01 15:57 |
| AXIS SPEED MONITOR | | 1240835465 |
| | LAST UPDATE | 2017/06/01 15:58 |
| ROBOT RANGE LIMIT | | 2902879382 |
| | LAST UPDATE | 2017/06/01 15:58 |
| SPEED LIMIT | | 3729081368 |
| | LAST UPDATE | 2017/06/01 15:58 |
| TOOL ANGLE MONITOR | | 1558066036 |
| | LAST UPDATE | 2017/06/01 15:58 |
| TOOL CHANGE MONITOR | | 4142362942 |
| | LAST UPDATE | 2017/06/01 16:13 |
| FCTN DEF PRMTR | | 3331128217 |
| | LAST UPDATE | 2017/06/01 16:01 |
| SYS DEF PRMTR | | 1122414420 |
| | LAST UPDATE | 2017/06/01 16:01 |
| SERVO PRMTR | | 3708503248 |
| | LAST UPDATE | 2017/06/01 16:02 |
| SERVOMOTOR PRMTR | | 2106023497 |
| | LAST UPDATE | 2017/06/01 16:03 |
| ROBOT MATCH PRMTR | | 1476936196 |
| | LAST UPDATE | 2017/06/01 16:02 |
| COORD ORG PRMTR | | 1809399432 |
| | LAST UPDATE | 2017/06/01 16:02 |
| MOTION FUNC PRMTR | | 0963122547 |
| | LAST UPDATE | 2017/06/01 16:02 |
| ROBOT EXPAND PRMTR | | 2220197393 |
| | LAST UPDATE | 2017/06/01 16:02 |
| SAFETY FUNCTION PRMTR | | 1404740907 |
| | LAST UPDATE | 2017/06/01 16:00 |
| SYS MATCH PRMTR | | 1963183572 |
| | LAST UPDATE | 2017/06/01 16:01 |
| SAFETY LOGIC CIRCUIT | | 0438869801 |
| | LAST UPDATE | 2017/06/01 16:03 |
| SAFETY LOGIC CIRCUIT(SYSTEM) | | 0438869801 |
| | LAST UPDATE | 2017/06/01 16:03 |

7 Data Protection

7.3 Change of Condition File by an External Device



The indication method of the TOTAL CRC CONFIRM window changes in the system software version YAS2.82.00A(□)-00 or later.

This window shows the last update of the total safety number derived from the CRC value of each data to be monitored by "monitoring target setting".

The CRC of each data can be sorted by data type by pressing {PAGE}.

For the data monitoring in the TOTAL CRC CONFIRM window, refer to *chapter 7.3.4 "Data Monitor on the Total CRC Confirmation Window"*.



"TOTAL SAFETY NUMBER" window shows the following items.

| Item | Description |
|-----------------------------------|--|
| TOTAL SAFETY NUMBER (LATCH) | "LAST UPDATE" when pressing {START} |
| TOTAL SAFETY NUMBER (LAST UPDATE) | The last update value of CRC for each data included in the "monitoring target setting" |
| MONITOR START | The last date and time when pressing {START} |
| RESULT | OK: The latch and the last update of the TOTAL SAFETY NUMBER are equal, and the data included in "monitoring target setting" is not changed. NG: The latch and the last update of the TOTAL SAFETY NUMBER are different, and the data included in "monitoring target setting" is changed. |

7 Data Protection

7.3 Change of Condition File by an External Device

“Each data” window shows below. The window when “SAFETY LOGIC CIRCUIT” included in “monitoring target setting” is selected is shown as an example.

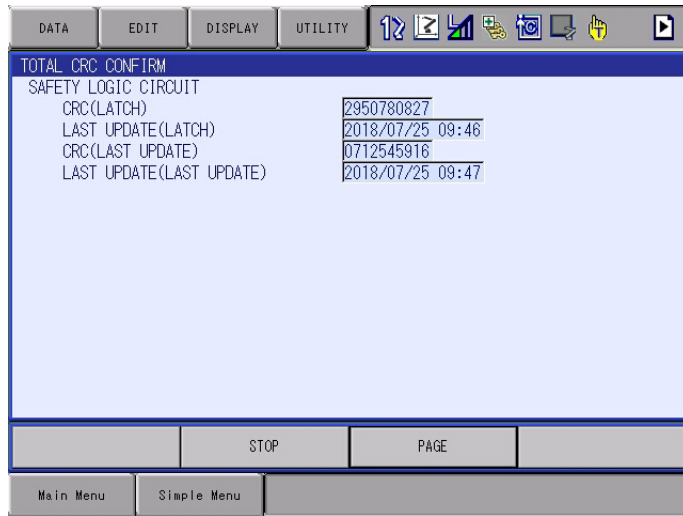

The descriptions of the items to be displayed are as follows.

| Item | Description |
|---------------------------|--|
| CRC (LATCH) | “LAST UPDATE” is reflected when pressing {START}. If not included in “monitoring target setting”, asterisks are displayed. |
| LAST UPDATE (LATCH) | “LAST UPDATE” is reflected when pressing {START}. If not included in “monitoring target setting”, asterisks are displayed. |
| CRC (LAST UPDATE) | The last update CRC value is displayed. However, in the functional safety function-relevant files, asterisks are displayed and the value is updated after the functional safety FLASH reset. Also, this value is consistent with the CRC value output to the file when saving to the external memory. |
| LAST UPDATE (LAST UPDATE) | The last update date and time is displayed. When never changed since the system started, asterisks are displayed. |

7 Data Protection

7.3 Change of Condition File by an External Device

The data types that the CRC can be displayed, corresponding to the valid/invalid of the optional function, are shown in the following table.

○: Display ×: Non-Display

| | Valid/Invalid of Optional Function | | | |
|---|------------------------------------|---------|---------|-------|
| | Invalid | Valid | Valid | Valid |
| Safety logic circuit expanded function | Invalid | Valid | Valid | Valid |
| Safety fieldbus | Invalid | Invalid | Valid | Valid |
| Functional safety | Invalid | Invalid | Invalid | Valid |
| Data Type | Display Possible / Impossible | | | |
| Total safety number | ○ | ○ | ○ | ○ |
| Safety logic circuit | ○ | ○ | ○ | ○ |
| Machine safety signal allocation | ○ | × | × | × |
| Timer delay | ○ | ○ | ○ | ○ |
| Safety signal board allocation | × | × | ○ | ○ |
| Functional safety signal allocation | × | × | × | ○ (*) |
| Safety circuit expanded signal allocation | × | × | × | ○ (*) |
| Timer | × | ○ | ○ | ○ |
| Safety circuit signal display setting | × | ○ | ○ | ○ |
| Tool | × | × | × | ○ |
| Tool interference | × | × | × | ○ |
| Home position calibration | × | × | × | ○ |
| Axis range limit | × | × | × | ○ |
| Axis speed monitor | × | × | × | ○ |
| Robot range limit | × | × | × | ○ |
| Speed limit | × | × | × | ○ |
| Tool angle monitor | × | × | × | ○ |
| Tool change monitor | × | × | × | ○ |
| Functional definition parameter | × | × | × | ○ |
| System definition parameter | × | × | × | ○ |
| Servo parameter | × | × | × | ○ |
| Servo motor parameter | × | × | × | ○ |
| Robot match parameter | × | × | × | ○ |
| Coordinate origin parameter | × | × | × | ○ |
| Motion function parameter | × | × | × | ○ |
| Robot expand parameter | × | × | × | ○ |
| Safety function parameter | × | × | × | ○ |

(*) The functional safety signal allocation and the safety circuit expanded signal allocation are displayed when both the safety logic circuit expanded function and the functional safety are valid.

7.3.3 Register Output of the CRC Value

By outputting the CRC value which is shown in the TOTAL CRC CONFIRM window to the general-purpose register, an external device can confirm that the file has been modified. By setting the parameter S4C1180 to S4C1207 shown in *table 7-2 "Allocation of Parameter for Register output of the CRC Value"*, the user can output the CRC value to the register.

Parameter setting value

0, 559 or more: The CRC value is not output to the general-purpose register.

1 to 558: The CRC value is output to the general-purpose register.

For the target files, refer to *table 7-2*. The two low-order bytes of the CRC value are output to the general-purpose register of specified number, and the two high-order bytes of the CRC value are output to the next general-purpose register.

Table 7-2: Allocation of Parameter for Register output of the CRC Value

| Parameter | CRC value output file |
|-----------|--|
| S4C1180 | Tool file |
| S4C1181 | Tool interference protection file |
| S4C1182 | Home position calibration data |
| S4C1183 | Axis range limit data |
| S4C1184 | Axis speed monitor data |
| S4C1185 | Robot range limit data |
| S4C1186 | Speed limit data |
| S4C1187 | Tool angle monitor data |
| S4C1188 | Tool change monitor data / Tool number select data |
| S4C1189 | Functional definition parameter |
| S4C1190 | System definition parameter |
| S4C1191 | Servo parameter |
| S4C1192 | Servo motor parameter |
| S4C1193 | Robot match parameter |
| S4C1194 | Coordinate origin parameter |
| S4C1195 | Motion function parameter |
| S4C1196 | Robot expand parameter |
| S4C1197 | Safety function parameter |
| S4C1198 | System match parameter |
| S4C1199 | Machine safety signal allocation |
| S4C1200 | Timer delay setting |
| S4C1201 | Safety signal board allocation |
| S4C1202 | Functional safety signal allocation |
| S4C1203 | Safety circuit expanded signal allocation |
| S4C1204 | Timer setting |
| S4C1205 | Safety circuit signal display setting |
| S4C1206 | Safety logic circuit |
| S4C1207 | Safety logic circuit (System) |

7 Data Protection
7.3 Change of Condition File by an External Device



NOTE

- When the general-purpose register which is specified as the output destination is used as the output destination (the current value of TMR/CNT instruction or the destination of the operating instruction) by the ladder program, the CRC value is not output. When setting, the register number must not be duplicated.
- When the Functional Safety Board FLASH Reset is required (the CRC value is shown as an asterisk on the TOTAL CRC CONFIRM window), the CRC value before updating is output to the general-purpose register.
- The CRC value of both the safety logic circuit and the safety logic circuit (system part) cannot be output.

7 Data Protection

7.3 Change of Condition File by an External Device

7.3.4 Data Monitor on the Total CRC Confirmation Window

On the total CRC confirmation window, the data to monitor can be selected and monitored.

The procedure of the data monitor on the total CRC confirmation window is as follows.

1. Change the mode to the security mode, and then select {SAFETY FUNC.} → {TOTAL CRC CONFIRM} under the main menu.
 - TOTAL CRC CONFIRM window appears.



2. Select {EDIT} → {SET CRC MONITOR}, and set the MONITOR to the Include/Not include.
 - If “STOP” is displayed on “TOTAL CRC CONFIRM” window, press “STOP” before setting.
 - When returning to “TOTAL CRC CONFIRM” window from “SET CRC MONITOR” window, press {RETURN}.
 - After setting, press {START}. Monitoring will start.

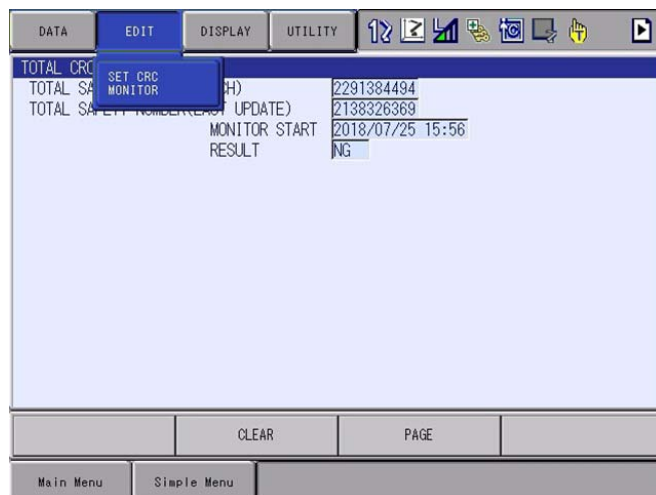

7 Data Protection
 7.3 Change of Condition File by an External Device

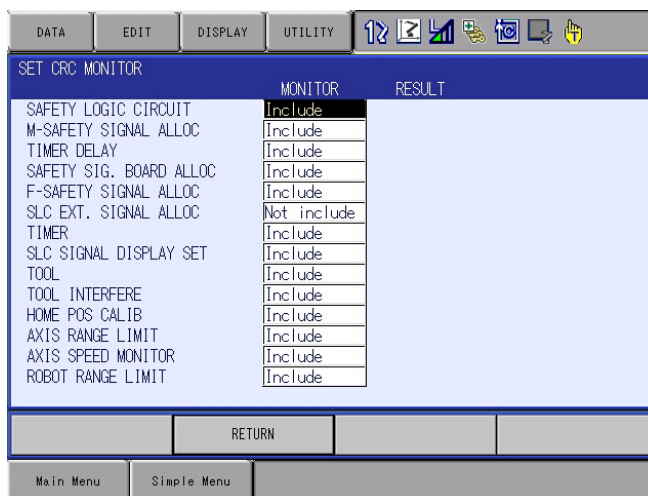

3. RESULT can be confirmed on the page of “Total safety number” on the TOTAL CRC CONFIRM window, on “SET CRC MONITOR” window, and by the specific output signal.
 - The page of total safety number

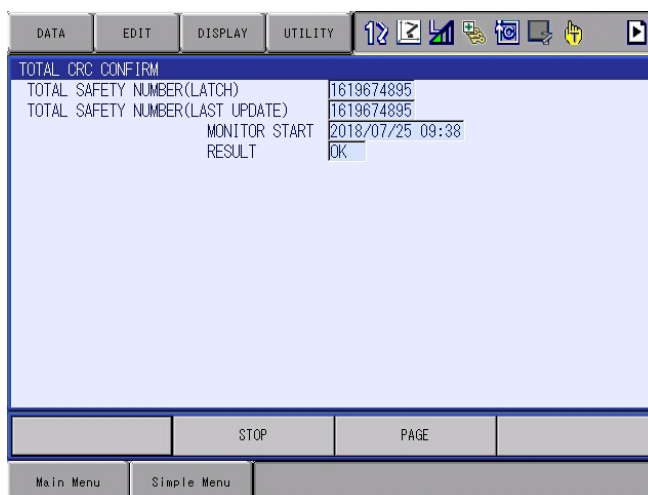

“TOTAL SAFETY NUMBER” window shows the following items.

| Item | Meaning |
|-----------------------------------|--|
| TOTAL SAFETY NUMBER (LATCH) | “LAST UPDATE” when pressing {START} |
| TOTAL SAFETY NUMBER (LAST UPDATE) | The last update value of CRC for each data included in “MONITOR” |
| MONITOR START | The last date and time when pressing {START} |
| RESULT | OK: The latch and the last update of the TOTAL SAFETY NUMBER are equal, and the data included in “MONITOR” is not changed. NG: The latch and the last update of the TOTAL SAFETY NUMBER are not equal, and the data included in “MONITOR” is changed. |

7 Data Protection
 7.3 Change of Condition File by an External Device

– SET MONITOR window

When the data set to “Include” on “MONITOR” is changed, NG is displayed on “RESULT”.

Only the items that included in the MONITOR during data monitor are displayed on the RESULT.

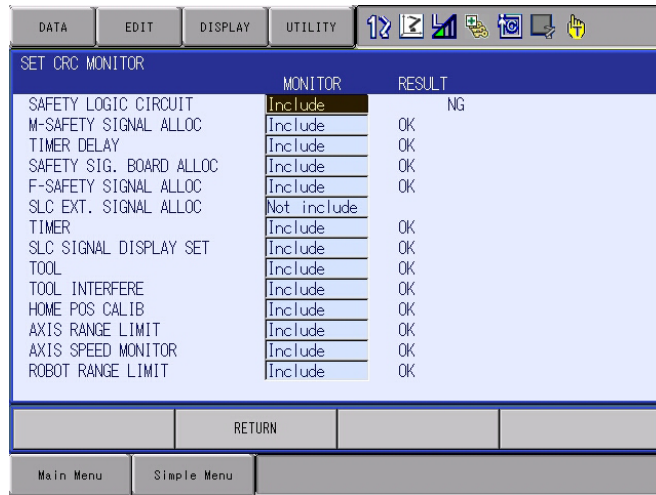

7 Data Protection
7.3 Change of Condition File by an External Device

- Specific output signal
For the monitoring result of each item, output to the specific output signal. For the item included in the MONITOR, when the CRC (LATCH) and the CRC (LAST UPDATE) are same, ON is output, and when not same, OFF is output. For the item not included in the MONITOR, OFF is output.

| Item | Specific output signal | Output value |
|---|------------------------|---|
| Total safety number | #52590 | ON: RESULT OK OFF: RESULT NG or Out of a Monitoring target |
| Safety logic circuit | #52591 | |
| Machine safety signal allocation | #52592 | |
| Timer delay | #52593 | |
| Safety signal board allocation | #52594 | |
| Functional safety signal allocation | #52595 | |
| Safety circuit expanded signal allocation | #52596 | |
| Timer | #52597 | |
| Safety circuit signal display setting | #52600 | |
| Tool | #52601 | |
| Tool interference | #52602 | |
| Home position calibration | #52603 | |
| Axis range limit | #52604 | |
| Axis speed monitor | #52605 | |
| Robot range limit | #52606 | |
| Speed limit | #52607 | |
| Tool angle monitor | #52610 | |
| Tool change monitor / Tool number select | #52611 | |
| Functional definition parameter | #52612 | |
| System definition parameter | #52613 | |
| Servo parameter | #52614 | |
| Servo motor parameter | #52615 | |
| Robot match parameter | #52616 | |
| Coordinate origin parameter | #52617 | |
| Motion function parameter | #52620 | |
| Robot expand parameter | #52621 | |
| Safety function parameter | #52622 | |
| Safety logic circuit (System) | #52623 | |
| System match parameter | #52624 | |

7 Data Protection

7.3 Change of Condition File by an External Device

7.3.5 Save Data CRC Check Function (FSU)

The save data CRC check function (FSU) is processing to check the CRC value created from the contents of the file data against the CRC value added into the file when loading the files (*table 7-1 "Files to which the CRC Value is output while Functional Safety is Valid"*) to be accessed in functional safety. This function can be set to valid or invalid.

When the function is set to valid, an alarm 4796: "Functional Safety Data CRC Error" occurs and the file cannot be loaded if the CRC value created from the contents of the file and the CRC value added into the file are different.

When the function is set to invalid, the CRC values are not checked.

Use the following procedure to set the save data CRC check function (FSU).

1. Set the security mode to safety mode, and then select {SETUP} - {FUNCTION ENABLE} under the main menu.



2. Set SAVE DATA CRC CHECK FUNC. (FSU) to "VALID".



- VALID

The CRC value check function is valid when a file is loaded for all files accessed in functional safety.

7 Data Protection

7.3 Change of Condition File by an External Device

- INVALID

The CRC value check function is invalid when a file is loaded for all files accessed in functional safety.

- INDIVIDUAL SET

Available to set whether the function is valid for each individual file. "INDIVIDUAL SET" can be set in system software version YAS4.74.00A(□)-00 or later.

3. When "INDIVIDUAL SET" is selected, set whether the function is valid for each individual file on the displayed window.



8 Specific Output Signal

Signals shown below are output to the concurrent I/O while the functional safety is used.



Signals output to the concurrent I/O are auxiliary signals only to check the status of the functional safety.

To implement the safety monitoring, use the safety output signal. (Refer to *chapter 5 "Safety Signal"* .)

- 52010 to 52047

Outputs the monitoring status (valid/invalid) of each condition file of the axis range limit function.

ON: Monitoring is valid

OFF: Monitoring is invalid

| 52017 | 52016 | 52015 | 52014 | 52013 | 52012 | 52011 | 52010 |
|------------------|------------------|------------------|------------------|------------------|------------------|------------------|------------------|
| SOUT#1608 | SOUT#1607 | SOUT#1606 | SOUT#1605 | SOUT#1604 | SOUT#1603 | SOUT#1602 | SOUT#1601 |
| Axis range limit | Axis range limit | Axis range limit | Axis range limit | Axis range limit | Axis range limit | Axis range limit | Axis range limit |
| Condition file 8 | Condition file 7 | Condition file 6 | Condition file 5 | Condition file 4 | Condition file 3 | Condition file 2 | Condition file 1 |
| Valid/Invalid | Valid/Invalid | Valid/Invalid | Valid/Invalid | Valid/Invalid | Valid/Invalid | Valid/Invalid | Valid/Invalid |

| 52027 | 52026 | 52025 | 52024 | 52023 | 52022 | 52021 | 52020 |
|-------------------|-------------------|-------------------|-------------------|-------------------|-------------------|-------------------|------------------|
| SOUT#1616 | SOUT#1615 | SOUT#1614 | SOUT#1613 | SOUT#1612 | SOUT#1611 | SOUT#1610 | SOUT#1609 |
| Axis range limit | Axis range limit | Axis range limit | Axis range limit | Axis range limit | Axis range limit | Axis range limit | Axis range limit |
| Condition file 16 | Condition file 15 | Condition file 14 | Condition file 13 | Condition file 12 | Condition file 11 | Condition file 10 | Condition file 9 |
| Valid/Invalid | Valid/Invalid | Valid/Invalid | Valid/Invalid | Valid/Invalid | Valid/Invalid | Valid/Invalid | Valid/Invalid |

| 52037 | 52036 | 52035 | 52034 | 52033 | 52032 | 52031 | 52030 |
|-------------------|-------------------|-------------------|-------------------|-------------------|-------------------|-------------------|-------------------|
| SOUT#1624 | SOUT#1623 | SOUT#1622 | SOUT#1621 | SOUT#1620 | SOUT#1619 | SOUT#1618 | SOUT#1617 |
| Axis range limit | Axis range limit | Axis range limit | Axis range limit | Axis range limit | Axis range limit | Axis range limit | Axis range limit |
| Condition file 24 | Condition file 23 | Condition file 22 | Condition file 21 | Condition file 20 | Condition file 19 | Condition file 18 | Condition file 17 |
| Valid/Invalid | Valid/Invalid | Valid/Invalid | Valid/Invalid | Valid/Invalid | Valid/Invalid | Valid/Invalid | Valid/Invalid |

| 52047 | 52046 | 52045 | 52044 | 52043 | 52042 | 52041 | 52040 |
|-------------------|-------------------|-------------------|-------------------|-------------------|-------------------|-------------------|-------------------|
| SOUT#1632 | SOUT#1631 | SOUT#1630 | SOUT#1629 | SOUT#1628 | SOUT#1627 | SOUT#1626 | SOUT#1625 |
| Axis range limit | Axis range limit | Axis range limit | Axis range limit | Axis range limit | Axis range limit | Axis range limit | Axis range limit |
| Condition file 32 | Condition file 31 | Condition file 30 | Condition file 29 | Condition file 28 | Condition file 27 | Condition file 26 | Condition file 25 |
| Valid/Invalid | Valid/Invalid | Valid/Invalid | Valid/Invalid | Valid/Invalid | Valid/Invalid | Valid/Invalid | Valid/Invalid |

8 Specific Output Signal

• 52050 to 52087

Outputs the monitoring status (valid/invalid) of each condition file of the axis speed monitor function.

ON: Monitoring is valid

OFF: Monitoring is invalid

| 52057 | 52056 | 52055 | 52054 | 52053 | 52052 | 52051 | 52050 |
|---|---|---|---|---|---|---|---|
| SOUT#1640 | SOUT#1639 | SOUT#1638 | SOUT#1637 | SOUT#1636 | SOUT#1635 | SOUT#1634 | SOUT#1633 |
| Axis speed monitor Condition file 8 | Axis speed monitor Condition file 7 | Axis speed monitor Condition file 6 | Axis speed monitor Condition file 5 | Axis speed monitor Condition file 4 | Axis speed monitor Condition file 3 | Axis speed monitor Condition file 2 | Axis speed monitor Condition file 1 |
| Valid/Invalid | Valid/Invalid | Valid/Invalid | Valid/Invalid | Valid/Invalid | Valid/Invalid | Valid/Invalid | Valid/Invalid |

| 52067 | 52066 | 52065 | 52064 | 52063 | 52062 | 52061 | 52060 |
|--|--|--|--|--|--|--|---|
| SOUT#1648 | SOUT#1647 | SOUT#1646 | SOUT#1645 | SOUT#1644 | SOUT#1643 | SOUT#1642 | SOUT#1641 |
| Axis speed monitor Condition file 16 | Axis speed monitor Condition file 15 | Axis speed monitor Condition file 14 | Axis speed monitor Condition file 13 | Axis speed monitor Condition file 12 | Axis speed monitor Condition file 11 | Axis speed monitor Condition file 10 | Axis speed monitor Condition file 9 |
| Valid/Invalid | Valid/Invalid | Valid/Invalid | Valid/Invalid | Valid/Invalid | Valid/Invalid | Valid/Invalid | Valid/Invalid |

| 52077 | 52076 | 52075 | 52074 | 52073 | 52072 | 52071 | 52070 |
|--|--|--|--|--|--|--|--|
| SOUT#1656 | SOUT#1655 | SOUT#1654 | SOUT#1653 | SOUT#1652 | SOUT#1651 | SOUT#1650 | SOUT#1649 |
| Axis speed monitor Condition file 24 | Axis speed monitor Condition file 23 | Axis speed monitor Condition file 22 | Axis speed monitor Condition file 21 | Axis speed monitor Condition file 20 | Axis speed monitor Condition file 19 | Axis speed monitor Condition file 18 | Axis speed monitor Condition file 17 |
| Valid/Invalid | Valid/Invalid | Valid/Invalid | Valid/Invalid | Valid/Invalid | Valid/Invalid | Valid/Invalid | Valid/Invalid |

| 52087 | 52086 | 52085 | 52084 | 52083 | 52082 | 52081 | 52080 |
|--|--|--|--|--|--|--|--|
| SOUT#1664 | SOUT#1663 | SOUT#1662 | SOUT#1661 | SOUT#1660 | SOUT#1659 | SOUT#1658 | SOUT#1657 |
| Axis speed monitor Condition file 32 | Axis speed monitor Condition file 31 | Axis speed monitor Condition file 30 | Axis speed monitor Condition file 29 | Axis speed monitor Condition file 28 | Axis speed monitor Condition file 27 | Axis speed monitor Condition file 26 | Axis speed monitor Condition file 25 |
| Valid/Invalid | Valid/Invalid | Valid/Invalid | Valid/Invalid | Valid/Invalid | Valid/Invalid | Valid/Invalid | Valid/Invalid |

8 Specific Output Signal

- 52090 to 52127
Outputs the monitoring status (valid/invalid) of each condition file of the robot range limit function.
ON: Monitoring is valid
OFF: Monitoring is invalid

| 52097 | 52096 | 52095 | 52094 | 52093 | 52092 | 52091 | 52090 |
|---|---|---|---|---|---|---|---|
| SOUT#1672 | SOUT#1671 | SOUT#1670 | SOUT#1669 | SOUT#1668 | SOUT#1667 | SOUT#1666 | SOUT#1665 |
| Robot range limit Condition file 8 Valid/Invalid | Robot range limit Condition file 7 Valid/Invalid | Robot range limit Condition file 6 Valid/Invalid | Robot range limit Condition file 5 Valid/Invalid | Robot range limit Condition file 4 Valid/Invalid | Robot range limit Condition file 3 Valid/Invalid | Robot range limit Condition file 2 Valid/Invalid | Robot range limit Condition file 1 Valid/Invalid |

| 52107 | 52106 | 52105 | 52104 | 52103 | 52102 | 52101 | 52100 |
|--|--|--|--|--|--|--|---|
| SOUT#1680 | SOUT#1679 | SOUT#1678 | SOUT#1677 | SOUT#1676 | SOUT#1675 | SOUT#1674 | SOUT#1673 |
| Robot range limit Condition file 16 Valid/Invalid | Robot range limit Condition file 15 Valid/Invalid | Robot range limit Condition file 14 Valid/Invalid | Robot range limit Condition file 13 Valid/Invalid | Robot range limit Condition file 12 Valid/Invalid | Robot range limit Condition file 11 Valid/Invalid | Robot range limit Condition file 10 Valid/Invalid | Robot range limit Condition file 9 Valid/Invalid |

| 52117 | 52116 | 52115 | 52114 | 52113 | 52112 | 52111 | 52110 |
|--|--|--|--|--|--|--|--|
| SOUT#1688 | SOUT#1687 | SOUT#1686 | SOUT#1685 | SOUT#1684 | SOUT#1683 | SOUT#1682 | SOUT#1681 |
| Robot range limit Condition file 24 Valid/Invalid | Robot range limit Condition file 23 Valid/Invalid | Robot range limit Condition file 22 Valid/Invalid | Robot range limit Condition file 21 Valid/Invalid | Robot range limit Condition file 20 Valid/Invalid | Robot range limit Condition file 19 Valid/Invalid | Robot range limit Condition file 18 Valid/Invalid | Robot range limit Condition file 17 Valid/Invalid |

| 52127 | 52126 | 52125 | 52124 | 52123 | 52122 | 52121 | 52120 |
|--|--|--|--|--|--|--|--|
| SOUT#1696 | SOUT#1695 | SOUT#1694 | SOUT#1693 | SOUT#1692 | SOUT#1691 | SOUT#1690 | SOUT#1689 |
| Robot range limit Condition file 32 Valid/Invalid | Robot range limit Condition file 31 Valid/Invalid | Robot range limit Condition file 30 Valid/Invalid | Robot range limit Condition file 29 Valid/Invalid | Robot range limit Condition file 28 Valid/Invalid | Robot range limit Condition file 27 Valid/Invalid | Robot range limit Condition file 26 Valid/Invalid | Robot range limit Condition file 25 Valid/Invalid |

8 Specific Output Signal

• 52130 to 52167

Outputs the monitoring status (valid/invalid) of each condition file of the speed limit function.

ON: Monitoring is valid

OFF: Monitoring is invalid

| 52137 | 52136 | 52135 | 52134 | 52133 | 52132 | 52131 | 52130 |
|------------------------------------|------------------------------------|------------------------------------|------------------------------------|------------------------------------|------------------------------------|------------------------------------|------------------------------------|
| SOUT#1704 | SOUT#1703 | SOUT#1702 | SOUT#1701 | SOUT#1700 | SOUT#1699 | SOUT#1698 | SOUT#1697 |
| Speed limit Condition file 8 | Speed limit Condition file 7 | Speed limit Condition file 6 | Speed limit Condition file 5 | Speed limit Condition file 4 | Speed limit Condition file 3 | Speed limit Condition file 2 | Speed limit Condition file 1 |
| Valid/Invalid | Valid/Invalid | Valid/Invalid | Valid/Invalid | Valid/Invalid | Valid/Invalid | Valid/Invalid | Valid/Invalid |

| 52147 | 52146 | 52145 | 52144 | 52143 | 52142 | 52141 | 52140 |
|-------------------------------------|-------------------------------------|-------------------------------------|-------------------------------------|-------------------------------------|-------------------------------------|-------------------------------------|------------------------------------|
| SOUT#1712 | SOUT#1711 | SOUT#1710 | SOUT#1709 | SOUT#1708 | SOUT#1707 | SOUT#1706 | SOUT#1705 |
| Speed limit Condition file 16 | Speed limit Condition file 15 | Speed limit Condition file 14 | Speed limit Condition file 13 | Speed limit Condition file 12 | Speed limit Condition file 11 | Speed limit Condition file 10 | Speed limit Condition file 9 |
| Valid/Invalid | Valid/Invalid | Valid/Invalid | Valid/Invalid | Valid/Invalid | Valid/Invalid | Valid/Invalid | Valid/Invalid |

| 52157 | 52156 | 52155 | 52154 | 52153 | 52152 | 52151 | 52150 |
|-------------------------------------|-------------------------------------|-------------------------------------|-------------------------------------|-------------------------------------|-------------------------------------|-------------------------------------|-------------------------------------|
| SOUT#1720 | SOUT#1719 | SOUT#1718 | SOUT#1717 | SOUT#1716 | SOUT#1715 | SOUT#1714 | SOUT#1713 |
| Speed limit Condition file 24 | Speed limit Condition file 23 | Speed limit Condition file 22 | Speed limit Condition file 21 | Speed limit Condition file 20 | Speed limit Condition file 19 | Speed limit Condition file 18 | Speed limit Condition file 17 |
| Valid/Invalid | Valid/Invalid | Valid/Invalid | Valid/Invalid | Valid/Invalid | Valid/Invalid | Valid/Invalid | Valid/Invalid |

| 52167 | 52166 | 52165 | 52164 | 52163 | 52162 | 52161 | 52160 |
|-------------------------------------|-------------------------------------|-------------------------------------|-------------------------------------|-------------------------------------|-------------------------------------|-------------------------------------|-------------------------------------|
| SOUT#1728 | SOUT#1727 | SOUT#1726 | SOUT#1725 | SOUT#1724 | SOUT#1723 | SOUT#1722 | SOUT#1721 |
| Speed limit Condition file 32 | Speed limit Condition file 31 | Speed limit Condition file 30 | Speed limit Condition file 29 | Speed limit Condition file 28 | Speed limit Condition file 27 | Speed limit Condition file 26 | Speed limit Condition file 25 |
| Valid/Invalid | Valid/Invalid | Valid/Invalid | Valid/Invalid | Valid/Invalid | Valid/Invalid | Valid/Invalid | Valid/Invalid |

8 Specific Output Signal

- 52130 to 52167
Outputs the monitoring status (valid/invalid) of each condition file of the tool angle monitor function.
ON: Monitoring is valid
OFF: Monitoring is invalid

| 52177 | 52176 | 52175 | 52174 | 52173 | 52172 | 52171 | 52170 |
|--|--|--|--|--|--|--|--|
| SOUT#1736 | SOUT#1735 | SOUT#1734 | SOUT#1733 | SOUT#1732 | SOUT#1731 | SOUT#1730 | SOUT#1729 |
| Tool angle monitor Condition file 8 Valid/Invalid | Tool angle monitor Condition file 7 Valid/Invalid | Tool angle monitor Condition file 6 Valid/Invalid | Tool angle monitor Condition file 5 Valid/Invalid | Tool angle monitor Condition file 4 Valid/Invalid | Tool angle monitor Condition file 3 Valid/Invalid | Tool angle monitor Condition file 2 Valid/Invalid | Tool angle monitor Condition file 1 Valid/Invalid |

| 52187 | 52186 | 52185 | 52184 | 52183 | 52182 | 52181 | 52180 |
|---|---|---|---|---|---|---|--|
| SOUT#1744 | SOUT#1743 | SOUT#1742 | SOUT#1741 | SOUT#1740 | SOUT#1739 | SOUT#1738 | SOUT#1737 |
| Tool angle monitor Condition file 16 Valid/Invalid | Tool angle monitor Condition file 15 Valid/Invalid | Tool angle monitor Condition file 14 Valid/Invalid | Tool angle monitor Condition file 13 Valid/Invalid | Tool angle monitor Condition file 12 Valid/Invalid | Tool angle monitor Condition file 11 Valid/Invalid | Tool angle monitor Condition file 10 Valid/Invalid | Tool angle monitor Condition file 9 Valid/Invalid |

| 52197 | 52196 | 52195 | 52194 | 52193 | 52192 | 52191 | 52190 |
|---|---|---|---|---|---|---|---|
| SOUT#1752 | SOUT#1751 | SOUT#1750 | SOUT#1749 | SOUT#1748 | SOUT#1747 | SOUT#1746 | SOUT#1745 |
| Tool angle monitor Condition file 24 Valid/Invalid | Tool angle monitor Condition file 23 Valid/Invalid | Tool angle monitor Condition file 22 Valid/Invalid | Tool angle monitor Condition file 21 Valid/Invalid | Tool angle monitor Condition file 20 Valid/Invalid | Tool angle monitor Condition file 19 Valid/Invalid | Tool angle monitor Condition file 18 Valid/Invalid | Tool angle monitor Condition file 17 Valid/Invalid |

| 52207 | 52206 | 52205 | 52204 | 52203 | 52202 | 52201 | 52200 |
|---|---|---|---|---|---|---|---|
| SOUT#1760 | SOUT#1759 | SOUT#1758 | SOUT#1757 | SOUT#1756 | SOUT#1755 | SOUT#1754 | SOUT#1753 |
| Tool angle monitor Condition file 32 Valid/Invalid | Tool angle monitor Condition file 31 Valid/Invalid | Tool angle monitor Condition file 30 Valid/Invalid | Tool angle monitor Condition file 29 Valid/Invalid | Tool angle monitor Condition file 28 Valid/Invalid | Tool angle monitor Condition file 27 Valid/Invalid | Tool angle monitor Condition file 26 Valid/Invalid | Tool angle monitor Condition file 25 Valid/Invalid |

8 Specific Output Signal

• 52210 to 52367

Outputs the monitoring status (valid/invalid) of each condition file of the tool change monitor function.

ON: Monitoring is valid

OFF: Monitoring is invalid

| 52217 | 52216 | 52215 | 52214 | 52213 | 52212 | 52211 | 52210 |
|---|---|---|---|---|---|---|---|
| SOUT#1768 | SOUT#1767 | SOUT#1766 | SOUT#1765 | SOUT#1764 | SOUT#1763 | SOUT#1762 | SOUT#1761 |
| Tool change monitor(R1) Condition file 8 Valid/Invalid | Tool change monitor(R1) Condition file 7 Valid/Invalid | Tool change monitor(R1) Condition file 6 Valid/Invalid | Tool change monitor(R1) Condition file 5 Valid/Invalid | Tool change monitor(R1) Condition file 4 Valid/Invalid | Tool change monitor(R1) Condition file 3 Valid/Invalid | Tool change monitor(R1) Condition file 2 Valid/Invalid | Tool change monitor(R1) Condition file 1 Valid/Invalid |

| 52227 | 52226 | 52225 | 52224 | 52223 | 52222 | 52221 | 52220 |
|--|--|--|--|--|--|--|---|
| SOUT#1776 | SOUT#1775 | SOUT#1774 | SOUT#1773 | SOUT#1772 | SOUT#1771 | SOUT#1770 | SOUT#1769 |
| Tool change monitor(R1) Condition file 16 Valid/Invalid | Tool change monitor(R1) Condition file 15 Valid/Invalid | Tool change monitor(R1) Condition file 14 Valid/Invalid | Tool change monitor(R1) Condition file 13 Valid/Invalid | Tool change monitor(R1) Condition file 12 Valid/Invalid | Tool change monitor(R1) Condition file 11 Valid/Invalid | Tool change monitor(R1) Condition file file10 Valid/Invalid | Tool change monitor(R1) Condition file 9 Valid/Invalid |

| 52237 | 52236 | 52235 | 52234 | 52233 | 52232 | 52231 | 52230 |
|---|---|---|---|---|---|---|---|
| SOUT#1784 | SOUT#1783 | SOUT#1782 | SOUT#1781 | SOUT#1780 | SOUT#1779 | SOUT#1778 | SOUT#1777 |
| Tool change monitor(R2) Condition file 8 Valid/Invalid | Tool change monitor(R2) Condition file 7 Valid/Invalid | Tool change monitor(R2) Condition file 6 Valid/Invalid | Tool change monitor(R2) Condition file 5 Valid/Invalid | Tool change monitor(R2) Condition file 4 Valid/Invalid | Tool change monitor(R2) Condition file 3 Valid/Invalid | Tool change monitor(R2) Condition file 2 Valid/Invalid | Tool change monitor(R2) Condition file 1 Valid/Invalid |

| 52247 | 52246 | 52245 | 52244 | 52243 | 52242 | 52241 | 52240 |
|--|--|--|--|--|--|--|---|
| SOUT#1792 | SOUT#1791 | SOUT#1790 | SOUT#1789 | SOUT#1788 | SOUT#1787 | SOUT#1786 | SOUT#1785 |
| Tool change monitor(R2) Condition file 16 Valid/Invalid | Tool change monitor(R2) Condition file 15 Valid/Invalid | Tool change monitor(R2) Condition file 14 Valid/Invalid | Tool change monitor(R2) Condition file 13 Valid/Invalid | Tool change monitor(R2) Condition file 12 Valid/Invalid | Tool change monitor(R2) Condition file 11 Valid/Invalid | Tool change monitor(R2) Condition file 10 Valid/Invalid | Tool change monitor(R2) Condition file 9 Valid/Invalid |

| 52257 | 52256 | 52255 | 52254 | 52253 | 52252 | 52251 | 52250 |
|---|---|---|---|---|---|---|---|
| SOUT#1800 | SOUT#1799 | SOUT#1798 | SOUT#1797 | SOUT#1796 | SOUT#1795 | SOUT#1794 | SOUT#1793 |
| Tool change monitor(R3) Condition file 8 Valid/Invalid | Tool change monitor(R3) Condition file 7 Valid/Invalid | Tool change monitor(R3) Condition file 6 Valid/Invalid | Tool change monitor(R3) Condition file 5 Valid/Invalid | Tool change monitor(R3) Condition file 4 Valid/Invalid | Tool change monitor(R3) Condition file 3 Valid/Invalid | Tool change monitor(R3) Condition file 2 Valid/Invalid | Tool change monitor(R3) Condition file 1 Valid/Invalid |

8 Specific Output Signal

| 52267 | 52266 | 52265 | 52264 | 52263 | 52262 | 52261 | 52260 |
|--|--|--|--|--|--|--|---|
| SOUT#1808 | SOUT#1807 | SOUT#1806 | SOUT#1805 | SOUT#1804 | SOUT#1803 | SOUT#1802 | SOUT#1801 |
| Tool change monitor(R3) Condition file 16 Valid/Invalid | Tool change monitor(R3) Condition file 15 Valid/Invalid | Tool change monitor(R3) Condition file 14 Valid/Invalid | Tool change monitor(R3) Condition file 13 Valid/Invalid | Tool change monitor(R3) Condition file 12 Valid/Invalid | Tool change monitor(R3) Condition file 11 Valid/Invalid | Tool change monitor(R3) Condition file 10 Valid/Invalid | Tool change monitor(R3) Condition file 9 Valid/Invalid |

| 52277 | 52276 | 52275 | 52274 | 52273 | 52272 | 52271 | 52270 |
|---|---|---|---|---|---|---|---|
| SOUT#1816 | SOUT#1815 | SOUT#1814 | SOUT#1813 | SOUT#1812 | SOUT#1811 | SOUT#1810 | SOUT#1809 |
| Tool change monitor(R4) Condition file 8 Valid/Invalid | Tool change monitor(R4) Condition file 7 Valid/Invalid | Tool change monitor(R4) Condition file 6 Valid/Invalid | Tool change monitor(R4) Condition file 5 Valid/Invalid | Tool change monitor(R4) Condition file 4 Valid/Invalid | Tool change monitor(R4) Condition file 3 Valid/Invalid | Tool change monitor(R4) Condition file 2 Valid/Invalid | Tool change monitor(R4) Condition file 1 Valid/Invalid |

| 52287 | 52286 | 52285 | 52284 | 52283 | 52282 | 52281 | 52280 |
|--|--|--|--|--|--|--|---|
| SOUT#1824 | SOUT#1823 | SOUT#1822 | SOUT#1821 | SOUT#1820 | SOUT#1819 | SOUT#1818 | SOUT#1817 |
| Tool change monitor(R4) Condition file 16 Valid/Invalid | Tool change monitor(R4) Condition file 15 Valid/Invalid | Tool change monitor(R4) Condition file 14 Valid/Invalid | Tool change monitor(R4) Condition file 13 Valid/Invalid | Tool change monitor(R4) Condition file 12 Valid/Invalid | Tool change monitor(R4) Condition file 11 Valid/Invalid | Tool change monitor(R4) Condition file 10 Valid/Invalid | Tool change monitor(R4) Condition file 9 Valid/Invalid |

| 52297 | 52296 | 52295 | 52294 | 52293 | 52292 | 52291 | 52290 |
|---|---|---|---|---|---|---|---|
| SOUT#1832 | SOUT#1831 | SOUT#1830 | SOUT#1829 | SOUT#1828 | SOUT#1827 | SOUT#1826 | SOUT#1825 |
| Tool change monitor(R5) Condition file 8 Valid/Invalid | Tool change monitor(R5) Condition file 7 Valid/Invalid | Tool change monitor(R5) Condition file 6 Valid/Invalid | Tool change monitor(R5) Condition file 5 Valid/Invalid | Tool change monitor(R5) Condition file 4 Valid/Invalid | Tool change monitor(R5) Condition file 3 Valid/Invalid | Tool change monitor(R5) Condition file 2 Valid/Invalid | Tool change monitor(R5) Condition file 1 Valid/Invalid |

| 52307 | 52306 | 52305 | 52304 | 52303 | 52302 | 52301 | 52300 |
|--|--|--|--|--|--|--|---|
| SOUT#1840 | SOUT#1839 | SOUT#1838 | SOUT#1837 | SOUT#1836 | SOUT#1835 | SOUT#1834 | SOUT#1833 |
| Tool change monitor(R5) Condition file 16 Valid/Invalid | Tool change monitor(R5) Condition file 15 Valid/Invalid | Tool change monitor(R5) Condition file 14 Valid/Invalid | Tool change monitor(R5) Condition file 13 Valid/Invalid | Tool change monitor(R5) Condition file 12 Valid/Invalid | Tool change monitor(R5) Condition file 11 Valid/Invalid | Tool change monitor(R5) Condition file 10 Valid/Invalid | Tool change monitor(R5) Condition file 9 Valid/Invalid |

| 52317 | 52316 | 52315 | 52314 | 52313 | 52312 | 52311 | 52310 |
|---|---|---|---|---|---|---|---|
| SOUT#1848 | SOUT#1847 | SOUT#1846 | SOUT#1845 | SOUT#1844 | SOUT#1843 | SOUT#1842 | SOUT#1841 |
| Tool change monitor(R6) Condition file 8 Valid/Invalid | Tool change monitor(R6) Condition file 7 Valid/Invalid | Tool change monitor(R6) Condition file 6 Valid/Invalid | Tool change monitor(R6) Condition file 5 Valid/Invalid | Tool change monitor(R6) Condition file 4 Valid/Invalid | Tool change monitor(R6) Condition file 3 Valid/Invalid | Tool change monitor(R6) Condition file 2 Valid/Invalid | Tool change monitor(R6) Condition file 1 Valid/Invalid |

8 Specific Output Signal

| 52327 | 52326 | 52325 | 52324 | 52323 | 52322 | 52321 | 52320 |
|--|--|--|--|--|--|--|---|
| SOUT#1856 | SOUT#1855 | SOUT#1854 | SOUT#1853 | SOUT#1852 | SOUT#1851 | SOUT#1850 | SOUT#1849 |
| Tool change monitor(R6) Condition file 16 Valid/Invalid | Tool change monitor(R6) Condition file 15 Valid/Invalid | Tool change monitor(R6) Condition file 14 Valid/Invalid | Tool change monitor(R6) Condition file 13 Valid/Invalid | Tool change monitor(R6) Condition file 12 Valid/Invalid | Tool change monitor(R6) Condition file 11 Valid/Invalid | Tool change monitor(R6) Condition file 10 Valid/Invalid | Tool change monitor(R6) Condition file 9 Valid/Invalid |

| 52347 | 52346 | 52345 | 52344 | 52343 | 52342 | 52341 | 52340 |
|---|---|---|---|---|---|---|---|
| SOUT#1872 | SOUT#1871 | SOUT#1870 | SOUT#1869 | SOUT#1868 | SOUT#1867 | SOUT#1866 | SOUT#1865 |
| Tool change monitor(R7) Condition file 8 Valid/Invalid | Tool change monitor(R7) Condition file 7 Valid/Invalid | Tool change monitor(R7) Condition file 6 Valid/Invalid | Tool change monitor(R7) Condition file 5 Valid/Invalid | Tool change monitor(R7) Condition file 4 Valid/Invalid | Tool change monitor(R7) Condition file 3 Valid/Invalid | Tool change monitor(R7) Condition file 2 Valid/Invalid | Tool change monitor(R7) Condition file 1 Valid/Invalid |

| 52357 | 52356 | 52355 | 52354 | 52353 | 52352 | 52351 | 52350 |
|--|--|--|--|--|--|--|---|
| SOUT#1880 | SOUT#1879 | SOUT#1878 | SOUT#1877 | SOUT#1876 | SOUT#1875 | SOUT#1874 | SOUT#1873 |
| Tool change monitor(R7) Condition file 16 Valid/Invalid | Tool change monitor(R7) Condition file 15 Valid/Invalid | Tool change monitor(R7) Condition file 14 Valid/Invalid | Tool change monitor(R7) Condition file 13 Valid/Invalid | Tool change monitor(R7) Condition file 12 Valid/Invalid | Tool change monitor(R7) Condition file 11 Valid/Invalid | Tool change monitor(R7) Condition file 10 Valid/Invalid | Tool change monitor(R7) Condition file 9 Valid/Invalid |

| 52357 | 52356 | 52355 | 52354 | 52353 | 52352 | 52351 | 52350 |
|---|---|---|---|---|---|---|---|
| SOUT#1880 | SOUT#1879 | SOUT#1878 | SOUT#1877 | SOUT#1876 | SOUT#1875 | SOUT#1874 | SOUT#1873 |
| Tool change monitor(R8) Condition file 8 Valid/Invalid | Tool change monitor(R8) Condition file 7 Valid/Invalid | Tool change monitor(R8) Condition file 6 Valid/Invalid | Tool change monitor(R8) Condition file 5 Valid/Invalid | Tool change monitor(R8) Condition file 4 Valid/Invalid | Tool change monitor(R8) Condition file 3 Valid/Invalid | Tool change monitor(R8) Condition file 2 Valid/Invalid | Tool change monitor(R8) Condition file 1 Valid/Invalid |

| 52367 | 52366 | 52365 | 52364 | 52363 | 52362 | 52361 | 52360 |
|--|--|--|--|--|--|--|---|
| SOUT#1888 | SOUT#1887 | SOUT#1886 | SOUT#1885 | SOUT#1884 | SOUT#1883 | SOUT#1882 | SOUT#1881 |
| Tool change monitor(R8) Condition file 16 Valid/Invalid | Tool change monitor(R8) Condition file 15 Valid/Invalid | Tool change monitor(R8) Condition file 14 Valid/Invalid | Tool change monitor(R8) Condition file 13 Valid/Invalid | Tool change monitor(R8) Condition file 12 Valid/Invalid | Tool change monitor(R8) Condition file 11 Valid/Invalid | Tool change monitor(R8) Condition file 10 Valid/Invalid | Tool change monitor(R8) Condition file 9 Valid/Invalid |

8 Specific Output Signal

• 52370 to 52407

Outputs the monitoring result for each condition file of the axis range limit function.

For details of the output value, refer to *chapter 5.5 “Safety Signal Output Value”*.

| 52377 | 52376 | 52375 | 52374 | 52373 | 52372 | 52371 | 52370 |
|---|---|---|---|---|---|---|---|
| SOUT#1896 | SOUT#1895 | SOUT#1894 | SOUT#1893 | SOUT#1892 | SOUT#1891 | SOUT#1890 | SOUT#1889 |
| Axis range limit Condition file 8 Monitoring result | Axis range limit Condition file 7 Monitoring result | Axis range limit Condition file 6 Monitoring result | Axis range limit Condition file 5 Monitoring result | Axis range limit Condition file 4 Monitoring result | Axis range limit Condition file 3 Monitoring result | Axis range limit Condition file 2 Monitoring result | Axis range limit Condition file 1 Monitoring result |

| 52387 | 52386 | 52385 | 52384 | 52383 | 52382 | 52381 | 52380 |
|--|--|--|--|--|--|--|---|
| SOUT#1904 | SOUT#1903 | SOUT#1902 | SOUT#1901 | SOUT#1900 | SOUT#1899 | SOUT#1898 | SOUT#1897 |
| Axis range limit Condition file 16 Monitoring result | Axis range limit Condition file 15 Monitoring result | Axis range limit Condition file 14 Monitoring result | Axis range limit Condition file 13 Monitoring result | Axis range limit Condition file 12 Monitoring result | Axis range limit Condition file 11 Monitoring result | Axis range limit Condition file 10 Monitoring result | Axis range limit Condition file 9 Monitoring result |

| 52397 | 52396 | 52395 | 52394 | 52393 | 52392 | 52391 | 52390 |
|--|--|--|--|--|--|--|--|
| SOUT#1912 | SOUT#1911 | SOUT#1910 | SOUT#1909 | SOUT#1908 | SOUT#1907 | SOUT#1906 | SOUT#1905 |
| Axis range limit Condition file 24 Monitoring result | Axis range limit Condition file 23 Monitoring result | Axis range limit Condition file 22 Monitoring result | Axis range limit Condition file 21 Monitoring result | Axis range limit Condition file 20 Monitoring result | Axis range limit Condition file 19 Monitoring result | Axis range limit Condition file 18 Monitoring result | Axis range limit Condition file 17 Monitoring result |

| 52407 | 52406 | 52405 | 52404 | 52403 | 52402 | 52401 | 52400 |
|--|--|--|--|--|--|--|--|
| SOUT#1920 | SOUT#1919 | SOUT#1918 | SOUT#1917 | SOUT#1916 | SOUT#1915 | SOUT#1914 | SOUT#1913 |
| Axis range limit Condition file 32 Monitoring result | Axis range limit Condition file 31 Monitoring result | Axis range limit Condition file 30 Monitoring result | Axis range limit Condition file 29 Monitoring result | Axis range limit Condition file 28 Monitoring result | Axis range limit Condition file 27 Monitoring result | Axis range limit Condition file 26 Monitoring result | Axis range limit Condition file 25 Monitoring result |

8 Specific Output Signal

• 52410 to 52447

Outputs the monitoring result for each condition file of the axis speed monitor function.

For details of the output value, refer to *chapter 5.5 "Safety Signal Output Value"*.

| 52417 | 52416 | 52415 | 52414 | 52413 | 52412 | 52411 | 52410 |
|---|---|---|---|---|---|---|---|
| SOUT#1928 | SOUT#1927 | SOUT#1926 | SOUT#1925 | SOUT#1924 | SOUT#1923 | SOUT#1922 | SOUT#1921 |
| Axis speed monitor Condition file 8 Monitoring result | Axis speed monitor Condition file 7 Monitoring result | Axis speed monitor Condition file 6 Monitoring result | Axis speed monitor Condition file 5 Monitoring result | Axis speed monitor Condition file 4 Monitoring result | Axis speed monitor Condition file 3 Monitoring result | Axis speed monitor Condition file 2 Monitoring result | Axis speed monitor Condition file 1 Monitoring result |

| 52427 | 52426 | 52425 | 52424 | 52423 | 52422 | 52421 | 52420 |
|--|--|--|--|--|--|--|---|
| SOUT#1936 | SOUT#1935 | SOUT#1934 | SOUT#1933 | SOUT#1932 | SOUT#1931 | SOUT#1930 | SOUT#1929 |
| Axis speed monitor Condition file 16 Monitoring result | Axis speed monitor Condition file 15 Monitoring result | Axis speed monitor Condition file 14 Monitoring result | Axis speed monitor Condition file 13 Monitoring result | Axis speed monitor Condition file 12 Monitoring result | Axis speed monitor Condition file 11 Monitoring result | Axis speed monitor Condition file 10 Monitoring result | Axis speed monitor Condition file 9 Monitoring result |

| 52437 | 52436 | 52435 | 52434 | 52433 | 52432 | 52431 | 52430 |
|--|--|--|--|--|--|--|--|
| SOUT#1944 | SOUT#1943 | SOUT#1942 | SOUT#1941 | SOUT#1940 | SOUT#1939 | SOUT#1938 | SOUT#1937 |
| Axis speed monitor Condition file 24 Monitoring result | Axis speed monitor Condition file 23 Monitoring result | Axis speed monitor Condition file 22 Monitoring result | Axis speed monitor Condition file 21 Monitoring result | Axis speed monitor Condition file 20 Monitoring result | Axis speed monitor Condition file 19 Monitoring result | Axis speed monitor Condition file 18 Monitoring result | Axis speed monitor Condition file 17 Monitoring result |

| 52447 | 52446 | 52445 | 52444 | 52443 | 52442 | 52441 | 52440 |
|--|--|--|--|--|--|--|--|
| SOUT#1952 | SOUT#1951 | SOUT#1950 | SOUT#1949 | SOUT#1948 | SOUT#1947 | SOUT#1946 | SOUT#1945 |
| Axis speed monitor Condition file 32 Monitoring result | Axis speed monitor Condition file 31 Monitoring result | Axis speed monitor Condition file 30 Monitoring result | Axis speed monitor Condition file 29 Monitoring result | Axis speed monitor Condition file 28 Monitoring result | Axis speed monitor Condition file 27 Monitoring result | Axis speed monitor Condition file 26 Monitoring result | Axis speed monitor Condition file 25 Monitoring result |

8 Specific Output Signal

• 52450 to 52487

Outputs the monitoring result for each condition file of robot range limit function.

For details of the output value, refer to *chapter 5.5 "Safety Signal Output Value"*.

| 52457 | 52456 | 52455 | 52454 | 52453 | 52452 | 52451 | 52450 |
|--|--|--|--|--|--|--|--|
| SOUT#1960 | SOUT#1959 | SOUT#1958 | SOUT#1957 | SOUT#1956 | SOUT#1955 | SOUT#1954 | SOUT#1953 |
| Robot range limit Condition file 8 Monitoring result | Robot range limit Condition file 7 Monitoring result | Robot range limit Condition file 6 Monitoring result | Robot range limit Condition file 5 Monitoring result | Robot range limit Condition file 4 Monitoring result | Robot range limit Condition file 3 Monitoring result | Robot range limit Condition file 2 Monitoring result | Robot range limit Condition file 1 Monitoring result |

| 52467 | 52466 | 52465 | 52464 | 52463 | 52462 | 52461 | 52460 |
|---|---|---|---|---|---|---|--|
| SOUT#1968 | SOUT#1967 | SOUT#1966 | SOUT#1965 | SOUT#1964 | SOUT#1963 | SOUT#1962 | SOUT#1961 |
| Robot range limit Condition file 16 Monitoring result | Robot range limit Condition file 15 Monitoring result | Robot range limit Condition file 14 Monitoring result | Robot range limit Condition file 13 Monitoring result | Robot range limit Condition file 12 Monitoring result | Robot range limit Condition file 11 Monitoring result | Robot range limit Condition file 10 Monitoring result | Robot range limit Condition file 9 Monitoring result |

| 52477 | 52476 | 52475 | 52474 | 52473 | 52472 | 52471 | 52470 |
|---|---|---|---|---|---|---|---|
| SOUT#1976 | SOUT#1975 | SOUT#1974 | SOUT#1973 | SOUT#1972 | SOUT#1971 | SOUT#1970 | SOUT#1969 |
| Robot range limit Condition file 24 Monitoring result | Robot range limit Condition file 23 Monitoring result | Robot range limit Condition file 22 Monitoring result | Robot range limit Condition file 21 Monitoring result | Robot range limit Condition file 20 Monitoring result | Robot range limit Condition file 19 Monitoring result | Robot range limit Condition file 18 Monitoring result | Robot range limit Condition file 17 Monitoring result |

| 52487 | 52486 | 52485 | 52484 | 52483 | 52482 | 52481 | 52480 |
|---|---|---|---|---|---|---|---|
| SOUT#1984 | SOUT#1983 | SOUT#1982 | SOUT#1981 | SOUT#1980 | SOUT#1979 | SOUT#1978 | SOUT#1977 |
| Robot range limit Condition file 32 Monitoring result | Robot range limit Condition file 31 Monitoring result | Robot range limit Condition file 30 Monitoring result | Robot range limit Condition file 29 Monitoring result | Robot range limit Condition file 28 Monitoring result | Robot range limit Condition file 27 Monitoring result | Robot range limit Condition file 26 Monitoring result | Robot range limit Condition file 25 Monitoring result |

8 Specific Output Signal

• 52490 to 52527

Outputs the monitoring result for each condition file of speed limit function.

For details of the output value, refer to *chapter 5.5 "Safety Signal Output Value"*.

| 52497 | 52496 | 52495 | 52494 | 52493 | 52492 | 52491 | 52490 |
|--|--|--|--|--|--|--|--|
| SOUT#1992 | SOUT#1991 | SOUT#1990 | SOUT#1989 | SOUT#1988 | SOUT#1987 | SOUT#1986 | SOUT#1985 |
| Speed limit Condition file 8 Monitoring result | Speed limit Condition file 7 Monitoring result | Speed limit Condition file 6 Monitoring result | Speed limit Condition file 5 Monitoring result | Speed limit Condition file 4 Monitoring result | Speed limit Condition file 3 Monitoring result | Speed limit Condition file 2 Monitoring result | Speed limit Condition file 1 Monitoring result |

| 52507 | 52506 | 52505 | 52504 | 52503 | 52502 | 52501 | 52500 |
|---|---|---|---|---|---|--|--|
| SOUT#2000 | SOUT#1999 | SOUT#1998 | SOUT#1997 | SOUT#1996 | SOUT#1995 | SOUT#1994 | SOUT#1993 |
| Speed limit Condition file 16 Monitoring result | Speed limit Condition file 15 Monitoring result | Speed limit Condition file 14 Monitoring result | Speed limit Condition file 13 Monitoring result | Speed limit Condition file 12 Monitoring result | Speed limit Condition file 11 Monitoring result | Speed limit Condition file 9 Monitoring result | Speed limit Condition file 8 Monitoring result |

| 52517 | 52516 | 52515 | 52514 | 52513 | 52512 | 52511 | 52510 |
|---|---|---|---|---|---|---|---|
| SOUT#2008 | SOUT#2007 | SOUT#2006 | SOUT#2005 | SOUT#2004 | SOUT#2003 | SOUT#2002 | SOUT#2001 |
| Speed limit Condition file 24 Monitoring result | Speed limit Condition file 23 Monitoring result | Speed limit Condition file 22 Monitoring result | Speed limit Condition file 21 Monitoring result | Speed limit Condition file 20 Monitoring result | Speed limit Condition file 19 Monitoring result | Speed limit Condition file 18 Monitoring result | Speed limit Condition file 17 Monitoring result |

| 52527 | 52526 | 52525 | 52524 | 52523 | 52522 | 52521 | 52520 |
|---|---|---|---|---|---|---|---|
| SOUT#2016 | SOUT#2015 | SOUT#2014 | SOUT#2013 | SOUT#2012 | SOUT#2011 | SOUT#2010 | SOUT#2009 |
| Speed limit Condition file 32 Monitoring result | Speed limit Condition file 31 Monitoring result | Speed limit Condition file 30 Monitoring result | Speed limit Condition file 29 Monitoring result | Speed limit Condition file 28 Monitoring result | Speed limit Condition file 27 Monitoring result | Speed limit Condition file 26 Monitoring result | Speed limit Condition file 25 Monitoring result |

8 Specific Output Signal

• 52530 to 52567

Outputs the monitoring result for each condition file of tool angle monitor function.

For details of the output value, refer to *chapter 5.5 "Safety Signal Output Value"*.

| 52537 | 52536 | 52535 | 52534 | 52533 | 52532 | 52531 | 52530 |
|---|---|---|---|---|---|---|---|
| SOUT#2024 | SOUT#2023 | SOUT#2022 | SOUT#2021 | SOUT#2020 | SOUT#2019 | SOUT#2018 | SOUT#2017 |
| Tool angle monitor Condition file 8 Monitoring result | Tool angle monitor Condition file 7 Monitoring result | Tool angle monitor Condition file 6 Monitoring result | Tool angle monitor Condition file 5 Monitoring result | Tool angle monitor Condition file 4 Monitoring result | Tool angle monitor Condition file 3 Monitoring result | Tool angle monitor Condition file 2 Monitoring result | Tool angle monitor Condition file 1 Monitoring result |

| 52547 | 52546 | 52545 | 52544 | 52543 | 52542 | 52541 | 52540 |
|--|--|--|--|--|--|--|---|
| SOUT#2032 | SOUT#2031 | SOUT#2030 | SOUT#2029 | SOUT#2028 | SOUT#2027 | SOUT#2026 | SOUT#2025 |
| Tool angle monitor Condition file 16 Monitoring result | Tool angle monitor Condition file 15 Monitoring result | Tool angle monitor Condition file 14 Monitoring result | Tool angle monitor Condition file 13 Monitoring result | Tool angle monitor Condition file 12 Monitoring result | Tool angle monitor Condition file 11 Monitoring result | Tool angle monitor Condition file 10 Monitoring result | Tool angle monitor Condition file 9 Monitoring result |

| 52557 | 52556 | 52555 | 52554 | 52553 | 52552 | 52551 | 52550 |
|--|--|--|--|--|--|--|--|
| SOUT#2040 | SOUT#2039 | SOUT#2038 | SOUT#2037 | SOUT#2036 | SOUT#2035 | SOUT#2034 | SOUT#2033 |
| Tool angle monitor Condition file 24 Monitoring result | Tool angle monitor Condition file 23 Monitoring result | Tool angle monitor Condition file 22 Monitoring result | Tool angle monitor Condition file 21 Monitoring result | Tool angle monitor Condition file 20 Monitoring result | Tool angle monitor Condition file 19 Monitoring result | Tool angle monitor Condition file 18 Monitoring result | Tool angle monitor Condition file 17 Monitoring result |

| 52567 | 52566 | 52565 | 52564 | 52563 | 52562 | 52561 | 52560 |
|--|--|--|--|--|--|--|--|
| SOUT#2048 | SOUT#2047 | SOUT#2046 | SOUT#2045 | SOUT#2044 | SOUT#2043 | SOUT#2042 | SOUT#2041 |
| Tool angle monitor Condition file 32 Monitoring result | Tool angle monitor Condition file 31 Monitoring result | Tool angle monitor Condition file 30 Monitoring result | Tool angle monitor Condition file 29 Monitoring result | Tool angle monitor Condition file 28 Monitoring result | Tool angle monitor Condition file 27 Monitoring result | Tool angle monitor Condition file 26 Monitoring result | Tool angle monitor Condition file 25 Monitoring result |

8 Specific Output Signal

• 52570 to 52577

For R1 to R8, outputs the monitoring result of the tool change monitor function.

ON: Normal

OFF: Abnormal

| 52577 | 52576 | 52575 | 52574 | 52573 | 52572 | 52571 | 52570 |
|---|---|---|---|---|---|---|---|
| SOUT#2056 | SOUT#2055 | SOUT#2054 | SOUT#2053 | SOUT#2052 | SOUT#2051 | SOUT#2050 | SOUT#2049 |
| Tool change monitor (R8) Monitoring result | Tool change monitor (R7) Monitoring result | Tool change monitor (R6) Monitoring result | Tool change monitor (R5) Monitoring result | Tool change monitor (R4) Monitoring result | Tool change monitor (R3) Monitoring result | Tool change monitor (R2) Monitoring result | Tool change monitor (R1) Monitoring result |

• 52580 to 52583

Outputs the status of the settings of the function disable mode.

• 52585

The comparison result of the following two tool files: the tool file that was last saved on the safety board and the tool file to use normally is output (TOOL.CND). ON is for the mismatch, and OFF is for the match.

| | 52585 | | 52583 | 52582 | 52581 | 52580 |
|--|----------------------------------|--|--|---|--|---|
| | SOUT#2062 | | SOUT#2060 | SOUT#2059 | SOUT#2058 | SOUT#2057 |
| | Tool file Comparison mismatch | | Tool change monitor Function disable mode | Tool angle monitor Function disable mode | Robot range limit Function disable mode | Axis speed monitor Function disable mode |

8 Specific Output Signal

• 52590 to 52645

The result of the data monitoring in the total CRC confirmation window is output. If the item is included in the monitoring target and is normal, ON is output, if it is abnormal, OFF is output, if it is not included in the monitoring target, OFF is output.

| 52597 | 52596 | 52595 | 52594 | 52593 | 52592 | 52591 | 52590 |
|---------------------------------|---|---|--|---------------------------------------|--|--|---------------------------------------|
| SOUT#2072 | SOUT#2071 | SOUT#2070 | SOUT#2069 | SOUT#2068 | SOUT#2067 | SOUT#2066 | SOUT#2065 |
| Timer setting Monitoring result | Safety logic circuit expanded signal allocation Monitoring result | Functional safety signal allocation Monitoring result | Safety signal board allocation Monitoring result | Timer delay setting Monitoring result | Machine safety signal allocation Monitoring result | Safety logic circuit Monitoring result | Total safety number Monitoring result |

| 52607 | 52606 | 52605 | 52604 | 52603 | 52602 | 52601 | 52600 |
|-------------------------------|-------------------------------------|--------------------------------------|------------------------------------|---|--|-----------------------------|---|
| SOUT#2080 | SOUT#2079 | SOUT#2078 | SOUT#2077 | SOUT#2076 | SOUT#2075 | SOUT#2074 | SOUT#2073 |
| Speed limit Monitoring result | Robot range limit Monitoring result | Axis speed monitor Monitoring result | Axis range limit Monitoring result | Home position calibration Monitoring result | Tool interference file Monitoring result | Tool file Monitoring result | Safety logic circuit signal display setting Monitoring result |

| 52617 | 52616 | 52615 | 52614 | 52613 | 52612 | 52611 | 52610 |
|---|---|---|-----------------------------------|---|---|---|--------------------------------------|
| SOUT#2088 | SOUT#2087 | SOUT#2086 | SOUT#2085 | SOUT#2084 | SOUT#2083 | SOUT#2082 | SOUT#2081 |
| Coordinate origin parameter Monitoring result | Robot match parameter Monitoring result | Servo motor parameter Monitoring result | Servo parameter Monitoring result | System definition parameter Monitoring result | Functional definition parameter Monitoring result | Tool change monitor/ Tool number select Monitoring result | Tool angle monitor Monitoring result |

| | | | | | 52622 | 52621 | 52620 |
|--|--|--|--|--|---|--|---|
| | | | | | SOUT#2091 | SOUT#2090 | SOUT#2089 |
| | | | | | Safety function parameter Monitoring result | Robot expand parameter Monitoring result | Motion function parameter Monitoring result |

8 Specific Output Signal

| | | 52635 | 52634 | 52633 | 52632 | 52631 | 52630 |
|--|--|--|--|---------------------------------------|---|--|--|
| | | SOUT#2102 | SOUT#2101 | SOUT#2100 | SOUT#2099 | SOUT#2098 | SOUT#2097 |
| | | Tool change monitor/Tool number select All files are invalid. | Tool angle monitor All files are invalid. | Speed limit All files are invalid. | Robot range limit All files are invalid. | Axis speed monitor All files are invalid. | Axis range limit All files are invalid. |

| | | 52645 | 52644 | 52643 | 52642 | 52641 | 52640 |
|--|--|---|---|--|--|---|---|
| | | SOUT#2110 | SOUT#2109 | SOUT#2108 | SOUT#2107 | SOUT#2106 | SOUT#2105 |
| | | Tool change monitor/Tool number select All files are set to default. | Tool angle monitor All files are set to default. | Speed limit All files are set to default. | Robot range limit All files are set to default. | Axis speed monitor All files are set to default. | Axis range limit All files are set to default. |

| | |
|-----|---|
| 9 | Restriction |
| 9.1 | Functions Cannot Be Used Concurrently with Functional Safety Function |

9 Restriction

9.1 Functions Cannot Be Used Concurrently with Functional Safety Function

9.1.1 Functions Which Modifies Parameter or File during Playback Operation

As explained in *chapter 7 "Data Protection"*, data of parameters or files are saved in a duplicated manner in the safety circuit board, and are verified for safety.

When modifying these data, special procedures such as read back operations or re-setting of the FLASH data are required.

For this reason, functions that modify parameters or file when executing the play back operation cannot be used concurrently with the functional safety function.

- Speed control function
- PMT function (SETTOOL instruction) (Can be used for YAS2.80.00A(*)-00 or later.)

To use the functional safety and PMT function (SETTOOL instruction) concurrently, refer to *chapter 6.6 "Using the PMT Function Together with the Functional Safety Function"*.

| | |
|-----|---|
| 9 | Restriction |
| 9.2 | Functions Conditionally Used Concurrently with Functional Safety Function |

9.2 Functions Conditionally Used Concurrently with Functional Safety Function

9.2.1 Conveyor Synchronized Function, COMARC Function

To the conveyor synchronized function and COMARC function, the speed for other purposes are added along with the normal operation speed in this consequence, there may be a case where the TCP speed or the flange speed cannot be controlled as specified.

Alarms and their countermeasures

Alarm 4785: F-SAFE SPEED MONITOR ERROR

Countermeasure: Set the limit value on the condition file with the calculated value on the basis of the speed added by each function.

Alarm 4786: F-SAFE TEACH SAFETY SPEED ERROR

Countermeasure: The operation speed of the manipulator exceeds the speed limited for the teach mode (250 [mm/sec]). Input a full speed test signal and disable the teach mode speed limit.

For the details, refer to *chapter 4.4.5 "Speed Limit in Teach Mode"*.

9.2.2 Servo Float Function

The manipulator position/speed and feedback position/speed may widely differ while the servo float function is executed. At this time, results of instruction monitoring and feed back monitoring vary.

The safety monitoring starts alarming at the earliest monitoring condition error in the instruction monitoring or feedback monitoring.

The monitoring is normally executed even in the system where the servo float function is available if this function is not executed (FLOATOF).

9.2.3 Motor Gun Function

The safety monitoring for the motor gun axis is not available. Functions such as the robot range limit function for the manipulator with the motor gun are available.

9.2.4 MotoPlus Function and MotoFit Function

When using the path correction function or the increment level movement function in the MotoPlus function or the Motofit function, the speed limit function is not available.

9.2.5 T-axis Endless Function, External Axis Endless Function

Safety monitoring cannot be performed for the axis which performs endless operation. For the axis which does not perform endless operation, safety monitoring is possible.

9.2.6 Gun Change Function and Group Change Function

With the functional safety, the position and the motion speed of the manipulator are calculated based on the feedback from the encoder, to perform a safety monitoring operation.

Thus, safety monitoring for a gun-change axis or a group-change axis whose communication with the encoder is temporarily disconnected cannot be performed.

However, the robot range monitoring, etc. for the manipulator which includes a gun-change axis or a group-change axis can be performed.

9.2.7 Multi Layer Function

When using the multi layer function, the tool angle monitor function cannot be used.

When the angle of the ground installation of the manipulator is except for 0° , the functional safety function is not available.

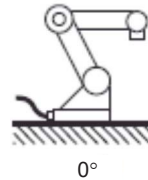

- 9 Restriction
- 9.3 Restriction of Operation

9.3 Restriction of Operation

When the functional safety function is available, operable security mode for the following data varies.

| Data | Operation | Security (When functional safety function is available) | Security (When functional safety function is not available) |
|------------------------------|--|--|--|
| Tool file | Editing on the tool file window | Safety ¹⁾ | Editing |
| | Tool calibration | Safety | Editing |
| | Automatic measurement of the tool load and the center of gravity | Safety | Editing |
| | Loading from the external memory device | Safety | Editing |
| | File initialization in the maintenance mode | Safety | Editing |
| Tool interference file | Editing on the tool interference file window | Safety ¹⁾ | Editing |
| | Loading from the external memory device | Safety | Editing |
| | File initialization in the maintenance mode | Safety | Editing |
| Home position | Edit on the home position window | Safety | Management |
| | Loading from the external memory device | Safety | Management |
| | File initialization in the maintenance mode | Safety | Management |
| | Zeroing function | Safety | Management |
| Each parameter ²⁾ | Loading from the external memory device | Safety | Management |
| | File initialization in the maintenance mode | Safety | Management |

1 This setting can be changed. For the details, refer to *chapter 6.5* "Security Level Setting for Tool File and Tool Interference Files".

2 Object parameters: ALL, RC, SD, RO, FD, SV, SVM, MF, RE, FMS

9.3.1 File/Parameter Loading

After loading the data related to the functional safety, re-set the data by following the procedures described in *chapter 7.2* "FLASH Data Reset". (After loading the data related to the functional safety, the message "Select 'Safety Board FLASH Reset' in the maintenance mode." appears.)

The following restrictions apply until the power supply to the YRC1000 is turned OFF.

- The servo cannot be turned ON.
- All of the safety monitoring functions of the functional safety are disabled.

10 Error

Errors related to the settings of the functional safety are listed in the following.

These errors warn the operator that it is impossible to advance to the next operation due to an incorrect operation or setting.

| Error No. | Data | Error Message | Contents |
|-----------|------|--|--|
| 1140 | - | No input signals are set. | |
| 1141 | - | Overlapped input signals exist. | |
| 1142 | - | Overlapped output signals exist. | |
| 1143 | - | The signal which cannot be used is set up. | |
| 1150 | * | There are abnormal values in the file. | |
| | 1 | | FILE NO. |
| | 2 | | FILE SET STATUS |
| | 3 | | FILE VALID CONDITION |
| | 4 | | ALARM SET |
| | 5 | | STOP METHOD |
| | 6 | | Control GROUP |
| | 7 | | Robot range limit: MONITOR TARGET |
| | 8 | | Robot range limit: COORDINATE |
| | 9 | | Robot range limit: SHAPE TYPE |
| | 10 | | Range combination: INPUT FILE1, INPUT FILE2 and OUTPUT FILE |
| 11 | | Range combination: LOGIC | |
| 1151 | * | Check the numeric value settings. | |
| | 1 | | Axis range limit: the valid axis can be set by maximum < minimum. |
| | 2 | | Robot range limit: set the "Z UPPER < Z LOWER" when the creating method is the prism. |
| | 4 | | Robot range limit: set the same coordinate at the two vertices of the plane monitoring. |

| Error No. | Data | Error Message | Contents |
|-----------|----------|--|--|
| 1152 | * | The set values are out of range. | |
| | 1 | | Axis range limit: maximum value and minimum value |
| | 2 | | Axis speed monitor: speed |
| | 3 | | Axis speed monitor: acceptable range |
| | 4 | | Speed limit: limit speed (Robot) |
| | 5 | | Speed limit: limit speed (Station) |
| | 6 | | Speed limit: detection delay time |
| | 7 | | Speed limit: acceptable range |
| | 8 | | Robot range limit: used point number |
| | 9 | | Robot range limit: X and Y coordinates |
| | 10 | | Robot range limit: Z coordinate |
| | 11 | | Approach warning buzzer: buzzer occurring distance |
| | 12 | | Approach warning buzzer: universal output number |
| | 13 | | Tool angle monitor: reference angle |
| | 14 | | Tool angle monitor: limit angle |
| | 16 | | Tool change monitor: tool number |
| | 17 | | Tool change monitor: detection delay time |
| 1160 | * | The selected control group cannot be applied to functional safety. | |
| | 2 | | The target group of the group change |
| | 3 | | The target group of the gun change |
| | 4 | | The group with the endless axis |
| | 5 | | The group with the speed control axis |
| | 6 | | The group with unsetting of the current position set up parameter |
| | 7 | | The group with unsetting of the approximation model |
| | 8 | | The group is not the monitoring target of the functional safety. |
| | 9 | | The group with the functional safety monitoring invalid axis |
| 1161 | * | The axis that cannot be applied to functional safety exist. | |
| | 10 to 17 | | The axis motion range limit and the axis speed monitor are valid, and the axes are endless axes (10+axis number). |
| | 20 to 27 | | The axis motion range limit and the axis speed monitor are valid, and the axes are speed control axes (20+axis number). |
| | 30 to 37 | | The axis motion range limit and the axis speed monitor are valid, and the axes are functional safety monitoring invalid axes (30+axis number). |
| 1162 | * | The axis to which coasting distance is not set cannot be set to VALID. | |
| | 0 to 7 | | The coasting values are not set when the axis is valid (axis number). |

| Error No. | Data | Error Message | Contents |
|-----------|------|--|---|
| 1163 | * | The group to which coasting distance is not set cannot be set to VALID. | |
| 1170 | * | Range cannot be configured with this setting. | |
| | 1 | | Invalid robot range limit file number |
| | 2 | | Inequality of the neighboring lines in the initial and terminal node |
| | 3 | | There is the same point at the specified vertex. |
| | 4 | | Lack of the setting vertex number |
| | 5 | | The setting range lines are interfering each other. |
| | 8 | | Inappropriate height setting |
| | 9 | | Detected the non-convex range |
| | 12 | | The exceeded number of the vertices |
| | 13 | | Failure to create the data for the monitoring the outside of the range. |
| 14 | | Failure to create the plane surface range. | |
| 1180 | - | Same file cannot be set. | |
| 1181 | - | The specified output file is under monitoring. | |
| 1182 | - | Monitor type differs between INPUT1 and INPUT2. | |
| 1183 | - | Coord type differs between INPUT1 and INPUT2. | |
| 1184 | - | The height in Z-direction differs between INPUT1 and INPUT2. | |
| 1185 | * | Range combination cannot be performed. | |
| | 1 | | Inappropriate specified combination |
| | 2 | | The exceeded number of the point of the intersection |
| | 3 | | Failure to combine the range "AND" |
| | 4 | | Failure to combine the range "OR" |
| 1186 | - | The combination use of the files where plane monitoring is set is not permitted. | |
| 1190 | - | Cannot modify this parameter. | |
| 1191 | - | Axis range limit function is temporally disabled. | |
| 1192 | - | Robot range limit function is temporally disabled. | |
| 1194 | - | Tool range limit function is temporally disable. | |
| 1195 | * | The tool No. must be the same as the registered tool No. | |
| | xxx | | The control group for the operation target. |
| 1196 | - | Select "Safety Board FLASH Reset". | |

YRC1000 OPTIONS INSTRUCTIONS

FOR FUNCTIONAL SAFETY FUNCTION

©2016 YASKAWA ELECTRIC CORPORATION
Published by YASKAWA

YASKAWA

YASKAWA ELECTRIC CORPORATION

August 2023 16-12

MANUAL NO.

HW1483576  208/208